



# 324-Port InfiniBand FDR SwitchX<sup>®</sup> Switch Platform Hardware User Manual

---

PN: SX6518-NR, SX6518-6R

Rev 2.9

## NOTE:

THIS HARDWARE, SOFTWARE OR TEST SUITE PRODUCT (PRODUCT(S)) AND ITS RELATED DOCUMENTATION ARE PROVIDED BY MELLANOX TECHNOLOGIES AS-IS WITH ALL FAULTS OF ANY KIND AND SOLELY FOR THE PURPOSE OF AIDING THE CUSTOMER IN TESTING APPLICATIONS THAT USE THE PRODUCTS IN DESIGNATED SOLUTIONS. THE CUSTOMER'S MANUFACTURING TEST ENVIRONMENT HAS NOT MET THE STANDARDS SET BY MELLANOX TECHNOLOGIES TO FULLY QUALIFY THE PRODUCT(S) AND/OR THE SYSTEM USING IT. THEREFORE, MELLANOX TECHNOLOGIES CANNOT AND DOES NOT GUARANTEE OR WARRANT THAT THE PRODUCTS WILL OPERATE WITH THE HIGHEST QUALITY. ANY EXPRESS OR IMPLIED WARRANTIES, INCLUDING, BUT NOT LIMITED TO, THE IMPLIED WARRANTIES OF MERCHANTABILITY, FITNESS FOR A PARTICULAR PURPOSE AND NON-INFRINGEMENT ARE DISCLAIMED. IN NO EVENT SHALL MELLANOX BE LIABLE TO CUSTOMER OR ANY THIRD PARTIES FOR ANY DIRECT, INDIRECT, SPECIAL, EXEMPLARY, OR CONSEQUENTIAL DAMAGES OF ANY KIND (INCLUDING, BUT NOT LIMITED TO, PAYMENT FOR PROCUREMENT OF SUBSTITUTE GOODS OR SERVICES; LOSS OF USE, DATA, OR PROFITS; OR BUSINESS INTERRUPTION) HOWEVER CAUSED AND ON ANY THEORY OF LIABILITY, WHETHER IN CONTRACT, STRICT LIABILITY, OR TORT (INCLUDING NEGLIGENCE OR OTHERWISE) ARISING IN ANY WAY FROM THE USE OF THE PRODUCT(S) AND RELATED DOCUMENTATION EVEN IF ADVISED OF THE POSSIBILITY OF SUCH DAMAGE.



Mellanox Technologies  
350 Oakmead Parkway Suite 100  
Sunnyvale, CA 94085  
U.S.A.  
[www.mellanox.com](http://www.mellanox.com)  
Tel: (408) 970-3400  
Fax: (408) 970-3403

© Copyright 2018. Mellanox Technologies Ltd All Rights Reserved

Mellanox®, Mellanox logo, Accelio®, BridgeX®, CloudX logo, CompustorX®, ConnectIB®, ConnectX®, CoolBox®, CORE-Direct®, EZchip®, EZchip logo, EZappliance®, EZdesign®, EZdriver®, EZsystem®, GPUDirect®, InfiniHost®, InfiniBridge®, InfiniScale®, LinkX®, Kotura®, Kotura logo, Mellanox CloudRack®, Mellanox CloudXMellanox®, Mellanox Federal Systems®, Mellanox HostDirect®, Mellanox Multi-Host®, Mellanox Open Ethernet®, Mellanox OpenCloud®, Mellanox OpenCloud Logo®, Mellanox PeerDirect®, Mellanox ScalableHPC®, Mellanox StorageX®, Mellanox TuneX®, Mellanox Connect Accelerate Outperform logo Mellanox Virtual Modular Switch®, MetroDX®, MetroX®, MLNX-OS®, NP-1c®, NP-2®, NP-3®, NPS®, Open Ethernet logo PhyX®, PlatformX®, PSIPHY®, SiPhy®, StoreX®, SwitchX®, Tiler®, Tiler logo TestX®, TuneX®, The Generation of Open Ethernet logo UFM®, Unbreakable Link®, Virtual Protocol Interconnect®, Voltaire® and Voltaire logo are registered trademarks of Mellanox Technologies Ltd.

All other trademarks are property of their respective owners

For the most updated list of Mellanox trademarks visit <http://www.mellanox.com/page/trademarks>

# Table of Contents

<b>Revision History</b> .....	<b>10</b>
<b>About this Manual</b> .....	<b>12</b>
<b>Chapter 1 Overview</b> .....	<b>14</b>
1.1 Product Information.....	14
1.1.1 Serial Number and Product Version Information.....	14
1.1.2 Management Module MAC .....	15
1.1.3 Product Physical Specifications and Power.....	15
1.2 Features List .....	17
1.3 InfiniBand FDR and FDR10 Overview .....	17
1.4 Power Supply Redundancy .....	18
1.4.1 1000W Power Supply Units .....	18
1.4.2 1670W Power Supply Units .....	18
<b>Chapter 2 Installation</b> .....	<b>20</b>
2.1 Installation Safety Warnings .....	20
2.2 Environmental and Safety Recommendations.....	25
2.3 Chassis Package Contents .....	25
2.4 Leaf Package Contents .....	26
2.5 Spine Package Contents.....	26
2.6 Management Package Contents .....	26
2.7 Physical Installation .....	26
2.7.1 Starting with the Rack.....	27
2.7.2 ESD Connection.....	28
2.7.3 Installation Procedure.....	28
2.7.4 Installing the Cable Holder.....	49
2.7.5 Ground Connections .....	50
2.8 Power Connections.....	51
2.8.1 Connecting to an AC power source .....	52
2.8.2 Powering Up the Switch Platform .....	52
2.9 InfiniBand QSFP Cable Installation .....	53
2.9.1 Supported Approved Cables.....	54
2.9.2 Cable Power Classes .....	54
2.10 Hot Swap Insertion and Extraction .....	55
2.10.1 Power Supply Units .....	55
2.10.2 Leaf Boards .....	56
2.10.3 Spine Boards .....	60
2.10.4 Fan Modules .....	65

2.10.5 Management Module .....	68
2.10.6 Switch Shut-Down Procedures .....	70
<b>Chapter 3 Interfaces .....</b>	<b>71</b>
3.1 LED Status Indicators .....	71
3.1.1 Power Supply Unit LEDs .....	71
3.1.2 Leaf Board LED Indicators.....	72
3.1.3 Spine Board LED Indicators .....	74
3.1.4 Spine Side Panel Display LED Indicators .....	76
3.1.5 Management Module LED Indicators .....	78
3.1.6 Port Connector Interfaces .....	80
3.2 Air Flow .....	80
3.3 QSFP Cable Power Budget Classification .....	80
3.4 Management Module Interfaces.....	80
3.4.1 I2C.....	81
3.4.2 CONSOLE .....	81
3.4.3 MGT– Management .....	81
3.4.4 USB.....	81
3.4.5 Reset – RST .....	82
3.5 AC power interface.....	82
<b>Chapter 4 Chassis Power Up .....</b>	<b>83</b>
4.1 Power Supply and Spine Board Indicator Status at Power ON .....	84
<b>Chapter 5 Switch Management Tools .....</b>	<b>85</b>
5.1 InfiniBand Subnet Manager .....	86
5.2 Fabric Inspector (Diagnostics) .....	86
5.3 Accessing the CPU via the Ethernet Connector .....	86
5.4 Upgrading and Downgrading Software.....	86
<b>Chapter 6 Troubleshooting .....</b>	<b>88</b>
6.1 Power Supply Unit .....	88
6.2 Leaf Board .....	88
6.3 Management Module .....	89
6.4 Spine Board.....	90
6.5 MLNX-OS® Software.....	90
<b>Chapter 7 Disassembly and Disposal .....</b>	<b>93</b>
7.1 Disassembling the Chassis .....	93
7.1.1 Removing the Chassis.....	93
7.1.2 Removing the Bottom Shelf .....	94
7.2 Disposal .....	95
<b>Appendix A Specification Data .....</b>	<b>96</b>

A.1	EMI Certification	98
A.2	Approved Cables	98
A.3	EMC Certifications	98
<b>Appendix B Thermal Threshold Definitions</b>		<b>99</b>
<b>Appendix C Calculating the Weight of a Customized Chassis</b>		<b>100</b>
<b>Appendix D Calculating the Power of a Chassis</b>		<b>101</b>
<b>Appendix E QSFP Interface</b>		<b>103</b>
<b>Appendix F Replacement Parts Ordering Numbers</b>		<b>106</b>
<b>Appendix G Safety Warnings (Multiple Languages)</b>		<b>108</b>
G.1	Nordic Countries Notices	108
G.2	Installation Safety Warnings (English)	108
G.3	אזהרות בטיחות בהתקנה (עברית)	111
G.4	安裝安全性警告 (Chinese)	114
G.5	Avertissements de sécurité pour l'installation (French)	118
G.6	Installation Sicherheitshinweise(German)	121
G.7	Advertencias de seguridad de instalación (Spanish)	124
G.8	Предупреждения по технике безопасности при установке (Russian)	127
G.9	Avertismente privind siguranța la instalare (Romanian)	130
G.10	Sigurnosna upozorenja za instaliranje (Croatian)	134
G.11	Avvertenze di sicurezza per l'installazione (italiano)	137
G.12	Montaj Güvenlik Uyarıları (Türkçe)	141
G.13	Japan VCCI Class A Statement	144

## List of Tables

Table 1:	Revision History of this User’s Manual . . . . .	10
Table 2:	Reference Documents and Websites . . . . .	12
Table 3:	OPNs for Power Supply Units . . . . .	19
Table 4:	Leaf Status LED . . . . .	73
Table 5:	Bad Port LED Configurations . . . . .	73
Table 6:	Connector Physical and Logical Link Indications . . . . .	73
Table 7:	Spine Status LED . . . . .	75
Table 8:	Spine Fan Status LED . . . . .	75
Table 9:	Spine to Leaf IB Link Status . . . . .	76
Table 10:	Bad Port LED Configurations . . . . .	76
Table 11:	Spine Side LED Display for Normal Operation . . . . .	77
Table 12:	Management LED Display for Normal Operation . . . . .	78
Table 13:	Management Module PSU LED Configurations . . . . .	79
Table 14:	Management Module S.Fan LED Configurations . . . . .	79
Table 15:	Management Module L.Fan LED Configurations . . . . .	79
Table 16:	Management Module MASTER LED Configurations . . . . .	80
Table 17:	Switch Specification SX6518 . . . . .	96
Table 18:	Switch System Weight Calculation . . . . .	100
Table 19:	Power Consumption of Chassis Parts . . . . .	101
Table 20:	QSFP Cable Power Consumption . . . . .	101
Table 21:	Calculating Total Switch System Power Consumption . . . . .	101
Table 22:	InfiniBand QSFP Connector Pinout . . . . .	103
Table 23:	Replacement Parts Ordering Numbers . . . . .	106

## List of Figures

Figure 1:	Product Label	14
Figure 2:	Product Label Tab Location	15
Figure 3:	Management Module MAC Address Location	15
Figure 4:	SX6518 Switch Views	16
Figure 5:	Distance Between the Vertical Supports	27
Figure 6:	Installation Kit Parts	30
Figure 7:	Shock Stickers	31
Figure 8:	Container Screws	32
Figure 9:	Vertical Rack Supports Dimension	34
Figure 10:	Placement of Chassis in Rack	34
Figure 11:	Adjustable Shelf Brackets	35
Figure 12:	Top of Shelf Bracket	36
Figure 13:	Placing the Shelf Bracket	36
Figure 14:	Caged Nut Locations for the Shelf Brackets	37
Figure 15:	Shelf Brackets	38
Figure 16:	U Numbering Above Shelf	38
Figure 17:	Putting the Chassis in the Rack Using a Fork Lift	39
Figure 18:	Putting the Chassis in the Rack Using a Mechanical Lift	40
Figure 19:	Place the Upper Bracket Offset	40
Figure 20:	Attach the Shelf Extension	41
Figure 21:	Caged Nut Placement by U Numbers	42
Figure 22:	Location for the Lock-Down Bar	43
Figure 23:	Fork Lift	43
Figure 24:	Mechanical Lift	43
Figure 25:	Face Plate Mounting Bolt Locations	44
Figure 26:	Upper Bracket Installation	45
Figure 27:	Upper Brackets and Offset Location	45
Figure 28:	Offset to Upper Bracket Bolts	46
Figure 29:	Location for the Lock-Down Bar	46
Figure 30:	Lock-Down Bar	46
Figure 31:	Lock-Down Bars Bolt and Washer Order	47
Figure 32:	Spine Side with Filler Panels	48
Figure 33:	Cable Holder	49
Figure 34:	Ground Connection	51

Figure 35: Multiple Power Inlets – Electric Caution Notification	53
Figure 36: Spine Module	53
Figure 37: Power Cord Numbering	56
Figure 38: Power Supply	56
Figure 39: Leaf Board Numbering	57
Figure 40: Ejector Handle	57
Figure 41: Leaf Release	58
Figure 42: Intact vs Defected Signal Connectors	58
Figure 43: Intact vs Defected Power Pin Holders	59
Figure 44: Management Module Numbering	61
Figure 45: Spine Board Extraction	61
Figure 46: Intact vs Defected Mechanics	62
Figure 47: Intact vs Defected Side Signal Connectors	63
Figure 48: Intact vs Defected Middle Signal Connectors	63
Figure 49: Intact vs Defected Power Pin Holders	64
Figure 50: Spine Board Insertion Caution	64
Figure 51: Leaf Fan Locations on the Chassis	65
Figure 52: Leaf Fan Module Extraction	66
Figure 53: Spine Fan Module	66
Figure 54: Fan Status LED on the Spine Module	67
Figure 55: Management Module	68
Figure 56: Intact vs Defected Signal Connectors	69
Figure 57: Intact vs Defected Power Pin Holders	69
Figure 58: Power Supply Unit Status Indications	71
Figure 59: PSU Cover On and Off	72
Figure 60: Leaf Board Led Indicators	72
Figure 61: Spine Status LEDs	75
Figure 62: Spine Side Panel Display Status Indications	77
Figure 63: Management Module Status Indications	78
Figure 64: Management Module LEDs	79
Figure 65: Port Numbering	80
Figure 66: Top and Bottom Ports	80
Figure 67: Management Module Interfaces	81
Figure 68: Reset Button	82
Figure 69: Spine Side Panel Display Status Indications	84
Figure 70: Management Module Status Indications for Normal Operation	84



Figure 71: SX65xx Downgrade Attention Sticker .....	87
Figure 72: Mechanical Lifting Device .....	94
Figure 73: InfiniBand QSFP Connector Symbol .....	104
Figure 74: QSFP Connector Male and Female Views .....	105

## Revision History

**Table 1 - Revision History of this User's Manual**

Revision	Date	Details
2.9	May 1, 2018	Updated: <ul style="list-style-type: none"> <li>Section 1.1.3, "Product Physical Specifications and Power," on page 15</li> </ul> Added note to Section 1.4.2, "1670W Power Supply Units," on page 18 Added Section 2.8.1, "Connecting to an AC power source," on page 52 Added Section 3.5, "AC power interface," on page 82
2.8	Oct 18, 2017	Added note to Section 2, "Installation," on page 20
2.7	Jan 02, 2017	Updated Section 5.4, "Upgrading and Downgrading Software," on page 86
2.6	Aug 29, 2016	Updated "Regulatory Compliance" in Table 17, "Switch Specification SX6518," on page 96 Removed Tilt Sticker figure from Section 2.7.3.3, "Container Mishandling," on page 30
2.5	Nov 30, 2015	Updated 1600W PSU power from 1600W to 1670W
2.4	Nov 26, 2015	Updated Appendix F, "Replacement Parts Ordering Numbers," on page 106 spine and leaf module OPNs
2.3	Nov 18, 2015	Updated Table 12, "Management LED Display for Normal Operation," on page 78
2.2	June 30, 2015	Updated: <ul style="list-style-type: none"> <li>Section 2.3, "Chassis Package Contents," on page 25</li> <li>Section G.13, "Japan VCCI Class A Statement," on page 144</li> </ul>
2.1	Feb 24, 2015	Updated: <ul style="list-style-type: none"> <li>Table 12, "Management LED Display for Normal Operation," on page 78 with master LED status indicators</li> <li>Appendix A, "Specification Data," on page 96 with FDR10 power numbers and max heat output</li> <li>Appendix D, "Calculating the Power of a Chassis," on page 101 with FDR10 power numbers</li> </ul>
2.0	Nov 17, 2014	Updated: <ul style="list-style-type: none"> <li>Section 1.4.2, "1670W Power Supply Units," on page 18</li> <li>Section 2.7.3.3, "Container Mishandling," on page 30</li> <li>Appendix A, "Specification Data," on page 96</li> </ul>
1.9	Oct 27, 2014	Updated: <ul style="list-style-type: none"> <li>Max. Air Flow numbers in Appendix A, "Specification Data," on page 96</li> <li>N+1 configuration in Section 1.4.2, "1670W Power Supply Units," on page 18</li> </ul>

**Table 1 - Revision History of this User's Manual**

Revision	Date	Details
1.8	July 17, 2014	Updated: <ul style="list-style-type: none"> <li>• Step 2 in Section 2.7.3.6, "Inserting the Chassis," on page 39</li> <li>• Section 2.7.5, "Ground Connections," on page 50</li> <li>• Appendix A, "Specification Data," on page 96</li> <li>• Appendix D, "Calculating the Power of a Chassis," on page 101</li> </ul>
1.7	January, 2014	Rearranged document: Consolidated installation sections under Chapter 2, "Installation," on page 20; updated Chapter 1, "Overview," on page 14; and re-ordered sections). Added: <ul style="list-style-type: none"> <li>• Figure 64, "Management Module LEDs," on page 79</li> </ul> Updated: <ul style="list-style-type: none"> <li>• Section 1.4, "Power Supply Redundancy," on page 18</li> <li>• Figure 6, "Installation Kit Parts," on page 30</li> <li>• Section 2.7.3.5, "Installing the Shelf," on page 33</li> <li>• Section 2.7.3.6, "Inserting the Chassis," on page 39</li> <li>• Section 2.7.4, "Installing the Cable Holder," on page 49</li> <li>• <b>FDR note</b> in Section 2.9, "InfiniBand QSFP Cable Installation," on page 53</li> <li>• Section 2.10, "Hot Swap Insertion and Extraction," on page 55</li> <li>• Section 7.1, "Disassembling the Chassis," on page 93</li> <li>• Table 17, "Switch Specification SX6518," on page 96</li> <li>• Appendix D, "Calculating the Power of a Chassis," on page 101</li> </ul>
1.6	May 2013	Changed the Installation kit to include the top and bottom filler panels Made changes regarding N+N Added note N+N only works for 220V inputs Added the filler panels to the disassembly section Added shelf to cable management system Changed figure # 16 Changed figure # 26 Fixed list of parts
1.5	November, 2012	Added grounding post size and thread. Section 2.7.5 Changed height to 18U Added note regarding inserting Spines from the bottom up. Added Figure 10
1.4	October, 2012	Updated graphics Fixed height of the shelf from 1U to 1.5 U in Spec Sheet and on page 35
1.3	October, 2012	New power numbers Changed Part numbering Legend Fixed height of the shelf from 1U to 1.5 U

**Table 1 - Revision History of this User's Manual**

Revision	Date	Details
1.2	July, 2012	Fixed broken link.
1.1	July, 2012	Added EMI explanation to Appendix Added Figure showing 2nd type of mechanical lift. Added explanation to N+2 Power Numbers. Added instructions to use the socket wrench to tighten the upper bracket. Added notes and warnings.
1.0	February, 2012	Initial release

## About this Manual

This manual provides an overview of the SwitchX® based SX6518 modular InfiniBand chassis switch, and guidelines for its operation.

## Intended Audience

This manual is intended for users and system administrators responsible for installing and setting up the chassis platform.

The manual assumes familiarity with the InfiniBand® architecture specification.

## Related Documentation

The documentation set accompanying the QSFP Chassis InfiniBand Switch platform includes the following:

**Table 2 - Reference Documents and Websites**

Document Name	Description
InfiniBand Architecture Specification, Vol. 1, Release 1.2.1	The InfiniBand Architecture Specification that is provided by IBTA
Switch Product Release Notes	For possible hardware issues see the switch support product page. This requires a customer support login. Look up the relevant SwitchX®-based switch system/series release note file.
Mellanox MLNX-OS® User Manual for VPI	This document contains information regarding configuring and managing Mellanox Technologies SwitchX® switch platforms listing all of the commands available through MLNX-OS with explanations and examples.

## Conventions

Throughout this manual, the name SX6518 and the terms chassis and switch are used to describe the 324 port QSFP InfiniBand chassis, unless explicitly indicated otherwise.

The following icons are used throughout this document to indicate information that is important to the user.

This symbol makes recommendations to the user.



This symbol indicates information that is helpful to the user.



This symbol indicates a situation that can potentially cause damage to hardware or software.



Warning! This symbol indicates a situation that can potentially cause personal injury and / or damage to hardware or software.

## Mellanox Part Numbering Legend

Command 1 -

Place	Field	Decoder
M		Mellanox Technologies
SX	System Type	SwitchX® Switch
PR	Data Transfer Protocol	(1, 2, 3, 4) = Ethernet (5, 6, 7, 8) = InfiniBand
G	Module Generation	5, 6, 7, 8
FF	Number of leafs	36, 18, 12, 06
C	Data Rate	B = 40Gb/s Ethernet F = FDR, T = FDR10, Q = QDR, D = DDR
-	Separator	
P	# Power Supplies	N = N+N redundant 1=1PSU, 2=2PSUs, ...
R	Chip Generation	R – SwitchX® S – SwitchX®-2

# 1 Overview

This User Manual provides an overview of the SX6518 QSFP Modular InfiniBand Switch Platform (known in this document as ‘the chassis or switch’) and its operational environment.

Mellanox SX6518 switch systems provide the highest performing fabric solution by delivering high bandwidth and low latency to Enterprise Data Centers (EDC), High-Performance Computing (HPC) and Embedded environments. Networks built with the SX6518 system can carry converged traffic with the combination of assured bandwidth and granular quality of service. Built with Mellanox’s 5<sup>th</sup> generation SwitchX® VPI switch device, SX6518 systems provide up to 56Gb/s full bidirectional bandwidth per port. With up to 324 ports in a 18U high form factor, these systems are among the densest switching systems available.

The switch platform comes pre-installed with all necessary firmware for standard operation within an InfiniBand fabric and requires an InfiniBand compliant Subnet Manager running from one of the hosts or the management module of the switch system. The initial configuration procedure should be followed to initialize the switch before connecting it to the network after which normal operation can proceed. (See the installation guide for details regarding the initial configuration.) Once connected to the network, the Subnet Management software automatically discovers and configures the fabric and begins utilizing the switch.

The Mellanox Operating System (MLNX-OS®) software package provides a subnet manager and network management tools as well as connectivity software for servers and storage, and is available on the Mellanox web site.

Basic installation is covered in [Chapter 2, “Installation” on page 20](#).

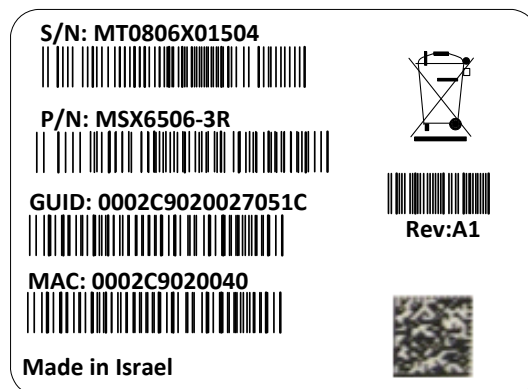
Hot-swapping components and hardware maintenance is covered in [Chapter 2.10, “Hot Swap Insertion and Extraction” on page 55](#).

## 1.1 Product Information

### 1.1.1 Serial Number and Product Version Information

The serial number, GUID identifier and product version information are found on the label attached to the pull-out tab below the Mellanox logo on the spine side of the chassis.

**Figure 1: Product Label**



The GUID is the System Image GUID according to the IB spec. It is burned on the board which is in the chassis. All the boards and the management software look for this GUID in addition to their own Node GUID.

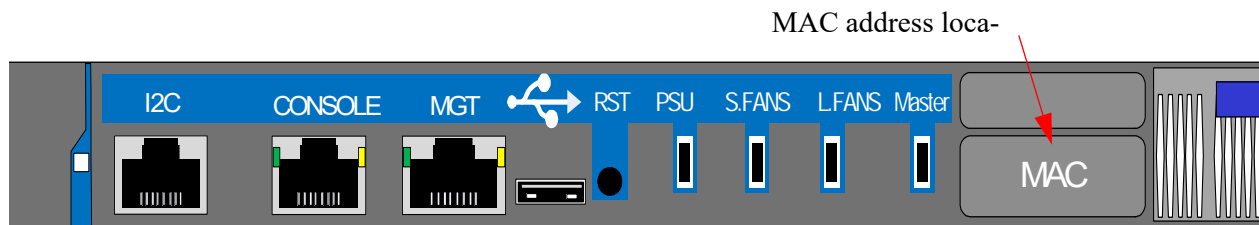
**Figure 2: Product Label Tab Location**



### 1.1.2 Management Module MAC

Each management module has a label with its MAC address. See Figure 3 for the location of this label.

**Figure 3: Management Module MAC Address Location**



### 1.1.3 Product Physical Specifications and Power

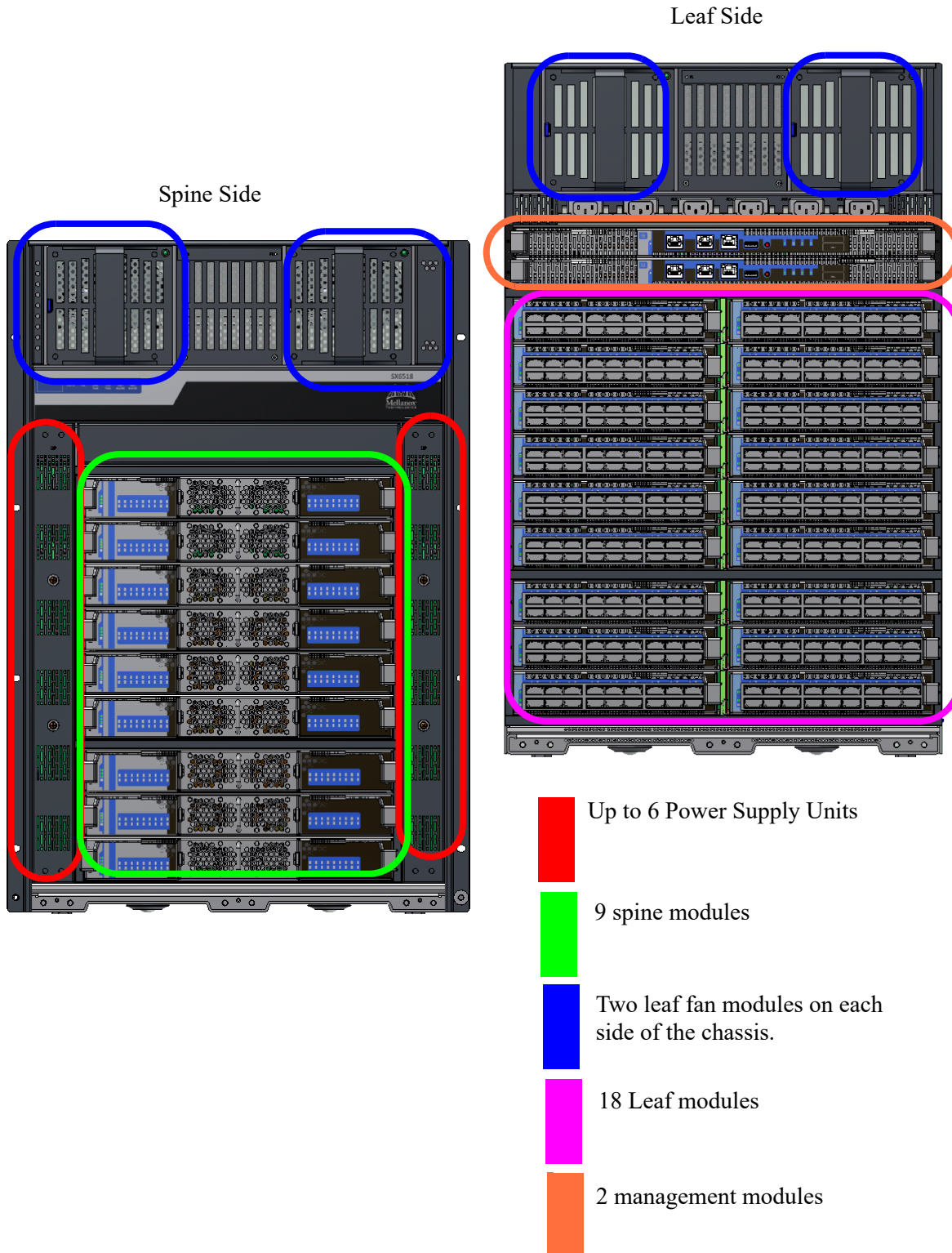
The system power interface is comprised of 6 C14 plugs, arranged in a row.

The switch ships in a minimum base configuration plus additional modules depending on the chosen customer configuration. Optional modules included:

- Leaf boards
- Management modules
- Spine boards

The following figure shows the connector and spine sides fully populated.

**Figure 4: SX6518 Switch Views**





## 1.2 Features List

- 324 FDR (56Gb/s) InfiniBand ports in a 16U switch
- 36.36 Tb/s aggregate data switching capacity with ultra low latency
- IBTA 1.3 and 1.2.1 compliant
- SDR/DDR/QDR/FDR10/FDR link speed
- N+N power supply
- Congestion control <sup>1</sup>
- Adaptive routing<sup>1</sup>
- Port mirroring<sup>1</sup>
- Chassis High Availability
- sMB High Availability

## 1.3 InfiniBand FDR and FDR10 Overview

The Mellanox SX6518 switch system supports FDR, standard InfiniBand data rate, where each lane of a 4X port runs a bit rate of 14.0625Gb/s with a 64b/66b encoding, resulting in an effective bandwidth of 54.54Gb/s. The FDR physical layer is an IBTA specified physical layer using different block types, deskew mechanism and framing rules.

The SX6518 switch also supports FDR10, a non-standard InfiniBand data rate, where each lane of a 4X port runs a bit rate of 10.3125Gb/s with a 64b/66b encoding, resulting in an effective bandwidth of 40Gb/s.

FDR10 supports 20% more bandwidth over regular QDR using the same QSFP cables/connectors.

Both FDR and FDR10 support Forward Error Correction (FEC), as described in IEEE Std 802.3ap-2007 (Amendment to IEEE Std 802.3-2005) chapter 74.



FDR and FDR10 are only guaranteed to work with approved Mellanox cables.



FDR10 is only guaranteed to work with approved Mellanox ConnectX-3 adapters.

1. Features for a future release.

## 1.4 Power Supply Redundancy

The SX6518 platform comes standard with six power supplies and has two order options:

- SX6518-6R - N+1 redundancy
- SX6518-NR - N+N redundancy

### 1.4.1 1000W Power Supply Units

The 1000W power supply units (PSUs) deliver 1000W at 48V. The AC source to each PSU must be able to provide 1176.5W in order to output 1000W in DC.

With 1000W PSUs the only redundancy option is N+2. In this configuration 2 PSUs can be extracted without bringing down the system. When using the 1000W PSUs, the minimum complement of PSUs at start-up is 6 and the chassis will continue to run at full capacity with only 4 PSUs.

### 1.4.2 1670W Power Supply Units

The 1670W power supply units (PSUs) deliver 1670W at 48V. The AC source to each PSU must be able to provide 1882.4W in order to output 1670W in DC.

When using the 1670W PSUs, the minimum complement of PSUs which allows the chassis to run at full capacity is 3.

The 1670W PSUs can implement the following two redundancy options:

- No redundancy (combined mode)
- N+1 configuration (ps-redundant mode)

When supplied from a single 220V power grid, the chassis supports up to 3 redundant units. Thereby, the minimum required number of PSUs equals 3. When supplied by a single 110V power grid, the number of redundant power supplies is only 1.

- N+N configuration (grid-redundant mode)



N+N redundancy ONLY works with a supply voltage of 220V.

The chassis PSUs are fed from two power grids for high availability. The second power grid can be supplied by any of the following:

- a backup power supply grid
- a generator
- a battery backup system
- any combination of the above

Connecting 3 power supplies to one power supply grid and the remaining 3 power supplies to a secondary power supply grid will create N+N redundancy. This is High Availability. Under these conditions should a power grid fail (an electric company power failure or blackout for

example) power grid High Availability will continue to keep the chassis running at full capacity through the secondary or backup power supply grid.

With N+N optional PSU grid redundancy the chassis can run on 1/2 of the full complement of PSUs. N+N allows the chassis to run on 3 PSUs supplied from one power grid while 3 are connected to a second power grid.



Supporting grid redundancy implies that each grid must be powered by separate PDU unit.



With power grid A charged with current and power grid B not charged there is only grid redundancy and not PSU redundancy.

When the power drops below the required minimum due to power supply failure, MLNX-OS® may power down some leafs. If this happens it may be necessary to reboot the chassis once the defective PSU has been replaced. Two simple ways to reboot is to use the reboot command in the CLI or reboot through the WebUI.

The form is identical between the two PSU types while the 1000W PSU weighs 0.3kg more than the 1670W PSU.

**Table 3 - OPNs for Power Supply Units**

OPN	PSU Wattage	Description
MTP005001	1000W	Supplies N+1 redundancy
MTP006002	1670W	Supplies N+N redundancy for all switch chassis at 220 Volts

## 2 Installation



This chassis can be installed in standard 19" racks that have depths between 65cm and 80cm between the vertical supports of the rack.

Installation and initialization of the chassis is a simple process requiring attention to the normal mechanical, power, and thermal precautions for rack-mounted equipment. Your chassis comes only with the power supplies and fans pre-installed. The rest of the openings are populated with blanks. All of the leafs, spines, and management modules come shipped in a separate package.

The chassis requires initial configuration to get the chassis and Fabric management up and running through remote management. See the Installation Guide that is packed in the box for the instructions to make the initial configuration.



This unit is intended for installation in a Restricted Access Location. A restricted access area can be accessed only through the use of a special tool, lock and key, or other means of security.



Unless otherwise specified, Mellanox products are designed to work in an environmentally controlled data center with low levels of gaseous and dust (particulate) contamination.

The operation environment should meet severity level G1 as per ISA 71.04 for gaseous contamination and ISO 14644-1 class 8 for cleanliness level

### 2.1 Installation Safety Warnings

These safety warnings are in English. For French, German, Spanish, Russian, and Romanian see the Appendixes.

#### 1. Installation Instructions

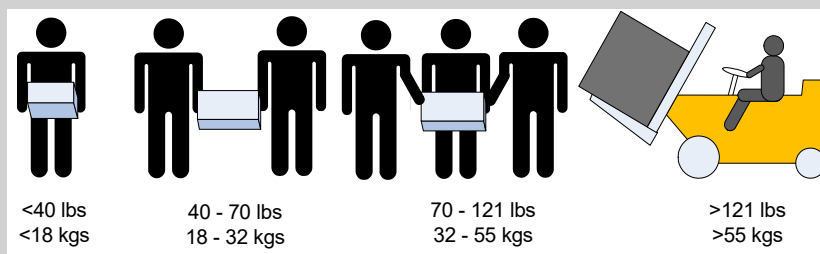


Read all installation instructions before connecting the equipment to the power source.

#### 2. Bodily Injury Due to Weight



Use enough people to safely lift this product.



### 3. Heavy Equipment



This equipment is very heavy and should be moved using a mechanical lift to avoid injuries.

### 4. Installation in Restricted Access Location



This unit is intended for installation in a Restricted Access Location.

### 5. Risk of Electric Shock!



Risk of Electric Shock!

With the fan module removed power pins are accessible within the module cavity. DO NOT insert tools or body parts into the fan module cavity.

### 6. Over-temperature



This equipment should not be operated in an area with an ambient temperature exceeding the maximum recommended: 45°C (113°F). Moreover, to guarantee proper air flow, allow at least 8cm (3 inches) of clearance around the ventilation openings.

### 7. Stacking the Chassis



The chassis should not be stacked on any other equipment. If the chassis falls, it can cause bodily injury and equipment damage.

### 8. Redundant Power Supply Connection - Electrical Hazard



This product includes a redundant power or a blank in its place. In case of a blank power supply, do not operate the product with the blank cover removed or not securely fastened.

### 9. Double Pole/Neutral Fusing



This system has double pole/neutral fusing. Remove all power cords before opening the cover of this product or touching any internal parts.

### 10. Multiple Power Inlets ,



Risk of electric shock and energy hazard.

The PSUs are all independent.

Disconnect all power supplies to ensure a powered down state inside of the switch platform.

### 11. During Lightning - Electrical Hazard



During periods of lightning activity, do not work on the equipment or connect or disconnect cables.

### 12. Copper InfiniBand Cable Connecting/Disconnecting



Copper InfiniBand cables are heavy and not flexible, as such they should be carefully attached to or detached from the connectors. Refer to the cable manufacturer for special warnings/instructions.

### 13. Rack Mounting and Servicing



When this product is mounted or serviced in a rack, special precautions must be taken to ensure that the system remains stable. In general you should fill the rack with equipment starting from the bottom to the top.

### 14. Equipment Installation



This equipment should be installed, replaced, and/or serviced only by trained and qualified personnel.

### 15. Equipment Disposal



Disposal of this equipment should be in accordance to all national laws and regulations.

### 16. Local and National Electrical Codes



This equipment should be installed in compliance with local and national electrical codes.

### 17. Installation Codes



This device must be installed according to the latest version of the country national electrical codes. For North America, equipment must be installed in accordance to the applicable requirements in the US National Electrical Code and the Canadian Electrical Code.

## 18. Battery Replacement



**Warning:** Replace only with UL Recognized battery, certified for maximum abnormal charging current not less than 4mA

There is a risk of explosion should the battery be replaced with a battery of an incorrect type.

Dispose of used batteries according to the instructions.

## 19. UL Listed and CSA Certified Power Supply Cord



For North American power connection, select a power supply cord that is UL Listed and CSA Certified, 3 - conductor, [16 AWG], terminated with a molded plug rated at 125 V, [13 A], with a minimum length of 1.5m [six feet] but no longer than 4.5m.

For European connection, select a power supply cord that is internationally harmonized and marked “<HAR>”, 3 - conductor, minimum 1.0 mm<sup>2</sup> wire, rated at 300 V, with a PVC insulated jacket. The cord must have a molded plug rated at 250 V, 10 A.

## 20. High Leakage Current



**Warning:** High leakage current; Earth connection essential before connecting supply.

## 21. Add GND connection information



Before connecting this device to the power line, the protective earth terminal screws of this device must be connected to the protective earth in the building installation.

(GND Connection Information):

The building installation shall provide a means for a connection to protective earth; and the equipment shall be permanently connected to that by a service person.

A SERVICE PERSON shall check whether or not the socket - outlet from which the equipment is to be powered provides a connection to the building protective earth. If not, the SERVICE PERSON shall arrange for the installation of a PROTECTIVE EARTHING CONDUCTOR from the separate protective earthing terminal to the protective earth wire in the building. The equipment shall be installed in area where equipotential bonding exists ((such as a telecommunication centre or a dedicated computer room).

## 22. Installation codes



This device must be installed according to the latest version of the country national electrical codes. For North America, equipment must be installed in accordance to the applicable requirements in the US National Electrical Code and the Canadian Electrical Code.

**23. Interconnection Of Units**



Cables for connecting to the unit RS232 and Ethernet Interfaces must be UL certified type DP-1 or DP-2. (Note- when residing in non LPS circuit)  
 Overcurrent Protection: A readily accessible Listed branch circuit overcurrent protective device rated 20 A must be incorporated in the building wiring.

**24. Hazardous Radiation Exposure**



Caution – Use of controls or adjustment or performance of procedures other than those specified herein may result in hazardous radiation exposure.



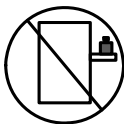
CLASS 1 LASER PRODUCT and reference to the most recent laser standards IEC 60 825-1:1993 + A1:1997 + A2:2001 and EN 60825-1:1994+A1:1996+A2:2001

**25. Proper Enclosure**



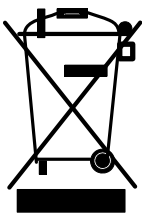
A suitable electrical, mechanical and fire enclosure shall be provided by the end product manufacturer and or the end user.

**26. Do Not Use the Switch as a Shelf or Work Space**



Caution: Slide/rail mounted equipment is not to be used as a shelf or a work space. The rails are not intended for sliding the unit away from the rack. It is for permanent installation at final resting place only, not used for service and maintenance

**27. WEEE Directive**



According to the WEEE Directive 2002/96/EC, all waste electrical and electronic equipment (EEE) should be collected separately and not disposed of with regular household waste.

Dispose of this product and all of its parts in a responsible and environmentally friendly way.



## 28. Country of Norway Power Restrictions



This unit is intended for connection to a TN power system and an IT power system of Norway only.

## 2.2 Environmental and Safety Recommendations

The following are Mellanox recommendations.

Recommended ambient temperature in the System room is  $20^{\circ} \pm 5^{\circ}$  C.  
Recommended humidity range is  $40\% \pm 15\%$  without condensing.

It is highly recommended that the installation sites be as isolated as possible from all sources of radio transmissions and electrical interference.

It is highly recommended that the installation site building be equipped with a lightning rod.

It is highly recommended that the installation site be equipped with smoke detectors and a fire alarm warning system.

The system requires a KVA rated UPS system. It is recommended that a UPS system be installed to protect the equipment in the event of unexpected power failure.



Make sure that the outlets and circuits will not be overloaded. Spread out the load over at least two or three circuits or use a 3 phase circuit.

## 2.3 Chassis Package Contents

The package includes:

- 1 chassis with the following modules installed:
  - 4 fans
  - 6 PSUs
- 1 installation guide
- 1 installation kit box
- 1 box containing 6 power cords 250v 15a 2.0M, C14 to C13, USA UL Standard
- 1 cable management kit
- 6 cable supporter boxes

Before you install your new SX6518 series chassis, unpack the system and check to make sure that all the parts have been sent, check this against the parts list. Check the parts for visible damage that may have occurred during shipping.



If anything is damaged or missing, contact your customer representative immediately.



The rack mounting holes conform to the EIA-310 standard for 19-inch racks. Guarantee proper ventilation, by leaving 8cm (3") of space to the front and rear of the switch. This will ensure proper air flow through the chassis. This is crucial for maintaining good airflow at ambient temperature. In particular, route cables such that they do not impede the air into or out of the chassis.

## 2.4 Leaf Package Contents

The leaves are ordered by the customer and are shipped 4 to a box. The customer will receive as many boxes as needed to fill the order.

## 2.5 Spine Package Contents

The spines are shipped 3 to a box. The customer will receive as many boxes as needed to fill the chassis with a full complement of spines.



Insert the bottom spine board first.

## 2.6 Management Package Contents

The package includes:

- all of the management modules ordered by the customer
- 1 RJ45 to DB9 harness for each management module received

## 2.7 Physical Installation



**Warning:** This equipment is very heavy. Safety is the first concern. Make sure that adequate manpower and proper equipment is used for transporting and moving the chassis.

The fully loaded chassis weighs:  
 212.36 kg (468 LBS) full configuration  
 90 kg (199 LBS) empty configuration  
 112 kg (247 LBS) shipped configuration

The switch platform uses 18U of rack space in a standard 19" rack, 16U for the chassis and 2U for the shelf. The switch ships from the factory with mounting holes on the spine side. There are

upper brackets to connect the leaf side to the rack near the top of the chassis, and there are two lock-down bars to secure the chassis to the shelf. The weight of the switch is supported from underneath the unit by the shelf.

This chassis can be installed in standard 19" racks that have between 65cm and 80cm between the vertical supports of the rack. Make sure that a fully populated rack including cables will have sufficient air flow for cooling.



Choose a rack which is able to support the mechanical and environmental characteristics of a fully populated switch chassis.

## 2.7.1 Starting with the Rack

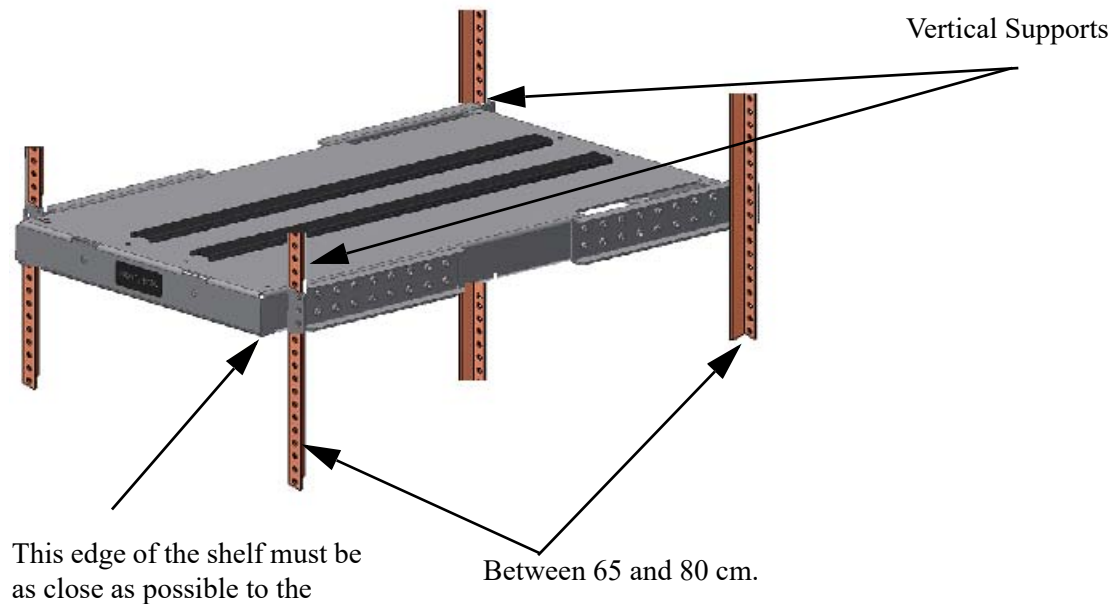
### Rack Recommendation

Due to the space required by up to 324 connector cables Mellanox recommends a rack that is 100 cm long and 80cm wide. This will allow for proper cable management and enough ventilation to properly cool the chassis.

#### 2.7.1.1 Preparing the Rack

The rack may need to be modified to accommodate the SX6518 chassis. The distance between the vertical supports must be between 65 and 80cm.

**Figure 5: Distance Between the Vertical Supports**



## 2.7.2 ESD Connection

Before starting any procedure on the SX6518 switch system:

1. Put an ESD prevention wrist strap on your wrist, and make sure there is good contact between your body and the strap.
2. Plug the other end of the wrist strap to a valid ground. Make sure that this is a tight fit.

## 2.7.3 Installation Procedure



Installing the chassis will be a lot easier if you can remove the sides of the rack.



You will need a fork lift, to move and insert the chassis into the rack.

### 2.7.3.1 Requirements

You will need:

- #2 phillips screwdriver
- a fork lift
- measuring tape
- #3 phillips screwdriver
- a grounding lug
- ground wire of sufficient length and gauge to properly ground the chassis

The installation will be much easier with a power screwdriver.

It is recommended to use AWG6 or 4mm diameter wire for grounding purposes.

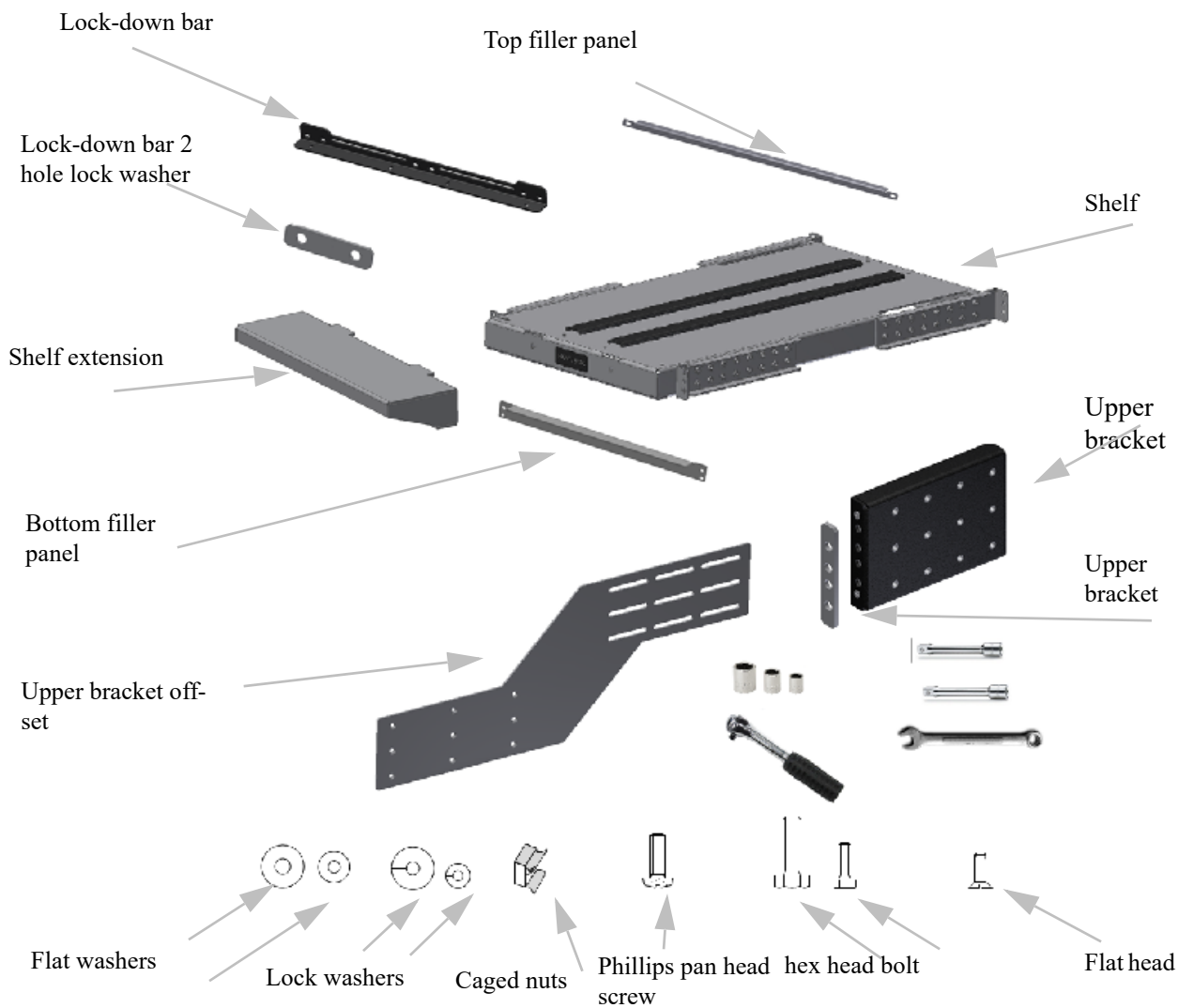
It is recommended to have at least two people for the duration of the installation procedure. Use a mechanical lift to raise this chassis. If not, use enough manpower to ensure the safety and wellbeing of all of the people involved in the installation.

### 2.7.3.2 Installation and Cable Management Kit Parts

- Parts included in the installation kit:
  - 1 shelf with brackets pre-installed
  - 1 left side upper bracket offset
  - 2 lock down bars
  - 8 lock washers for the upper brackets to vertical support
  - 10 hex head bolts – 8 for the upper brackets and 2 for the shelf extension
  - 1 shelf extension
  - 1 right side upper bracket offset
  - 2 upper bracket washers
  - 1 nut Size M-6 for ground post
  - 26 caged nuts 12 for the shelf and 8 for the chassis faceplate and 6 for the filler panels

- 26 pan head screws for the caged nuts 12 for the shelf and 8 for the chassis faceplate and 6 for the filler panels
  - 32 lock washers – 20 for the lock down bars and 12 for the upper brackets to upper bracket offsets
  - 2 upper brackets
  - 1 open end ratchet wrench 10mm
  - 1 socket wrench
  - 2 extensions for the socket driver
  - 2 flat washers for the shelf extension
  - Bottom filler panel
  - 32 hex head bolts – 20 for the lock down bars and 12 for the upper brackets to upper bracket offsets
  - 12 flat head screws for the upper bracket offsets
  - 1 socket nut driver 8mm
  - 1 socket nut driver 10mm
  - 1 socket nut driver 14mm
  - 1 box wrench
  - 6 two hole lock washers for lock down bars
  - Top filler panel
- Parts included in the cable management installation kit:
    - 1 cable management rack RH
    - 14 caged nuts M6
    - 9 cable management shelves
    - 1 cable management rack LH
    - 14 M6 bolts

**Figure 6: Installation Kit Parts**



### 2.7.3.3 Container Mishandling

The container has shock stickers applied. The shock stickers turn red if the container has been mishandled or roughly handled. Upon receipt of the container look for and inspect the shock stickers to confirm that they have not tripped. If a shock sticker or more are red, notify the shipper and Mellanox. This on its own does not indicate damage to the contents. But, be sure to carefully inspect the contents if any of the shock stickers have tripped.

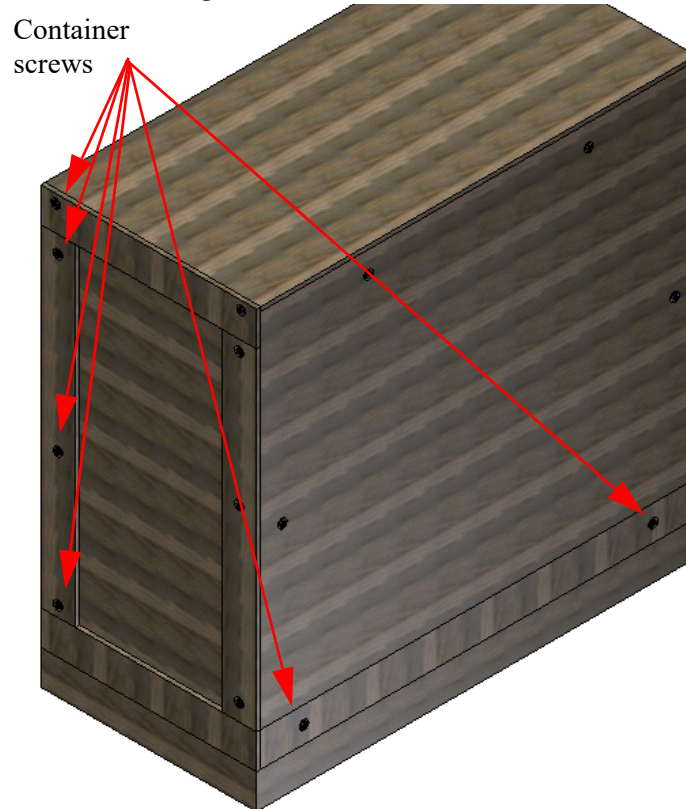
Figure 7: Shock Stickers



### 2.7.3.4 Opening the Container

1. Before starting the procedure, put the ESD strap on and connect it to a valid ground.

**Figure 8: Container Screws**



It is highly recommended to have a screw gun or electric screwdriver for this step.

2. Remove the four sides of the container by unscrewing the phillips head screws holding the sides on.
3. Remove and put aside the box.
4. Visually inspect the chassis, make sure that:
  - there is no visible damage
  - 6 PSUs are installed for the chassis
  - all 4 fans are installed
5. Remove all protective plastic film from all sides and top of the chassis.



The leaves, spines, and management modules are shipped separately.





Do not remove any of the blocks or either of the lock-down bars at this time.

### 2.7.3.5 Installing the Shelf



The chassis is on ball bearings and can roll easily. Be aware that the chassis can roll off of the pallet. **Should the chassis start to fall, move out of the way.** The chassis can cause grave bodily harm should it fall on or near you.

1. Select the location in the rack. Try to keep the chassis as low as possible to keep the center of gravity low.

It is recommended to set the top of the shelf at U5. Try and keep the chassis as low as possible.

Placing the shelf too low may make it impossible to tighten the shelf brackets, in Step 11.

The maximum height that the chassis can be mounted, will be determined by the maximum height that the fork lift can raise the pallet.

2. Open the Installation kit and make sure that all of the parts are in the box. See Figure 6, “Installation Kit Parts”.

The chassis should sit in the rack with the spine side as close as possible to the door. This leaves maximum room for the cable management system.

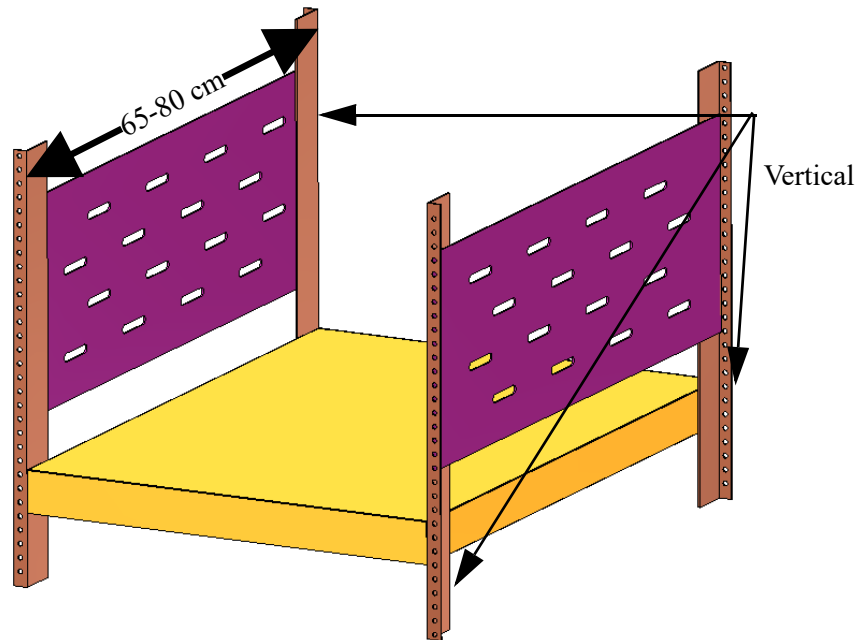


The distance between the vertical supports must be between 65 cm(25.6”) and 80 cm(31.5”). If the distance in your rack is different, move the vertical supports so that one pair is ~10 cm(4in.) away from the door.



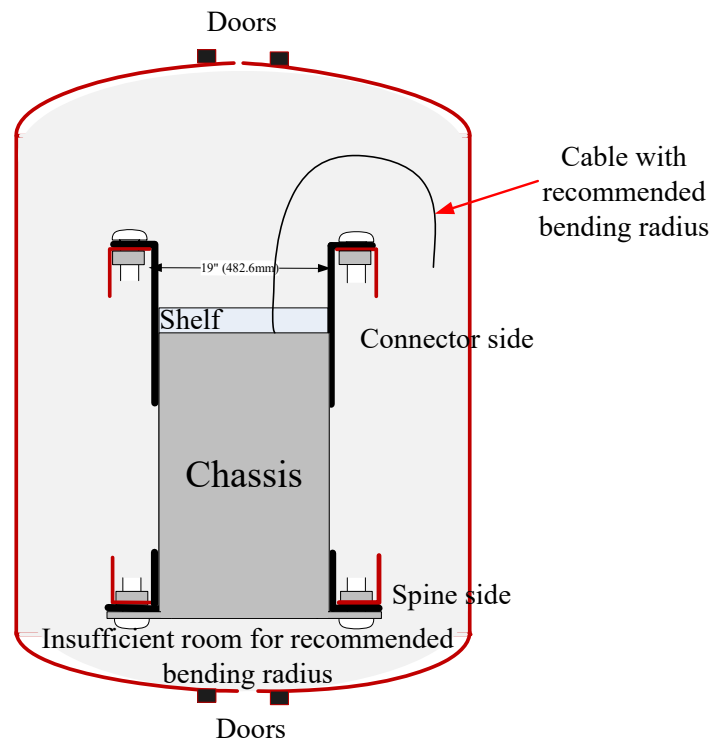
The side of the chassis with the spine units will sit flush with the vertical supports of the rack. The side of the chassis with the QSFP connectors will sit at the edge of the shelf closer to the center of the rack.

**Figure 9: Vertical Rack Supports Dimension**



3. Decide which side of the rack you want the data connectors.

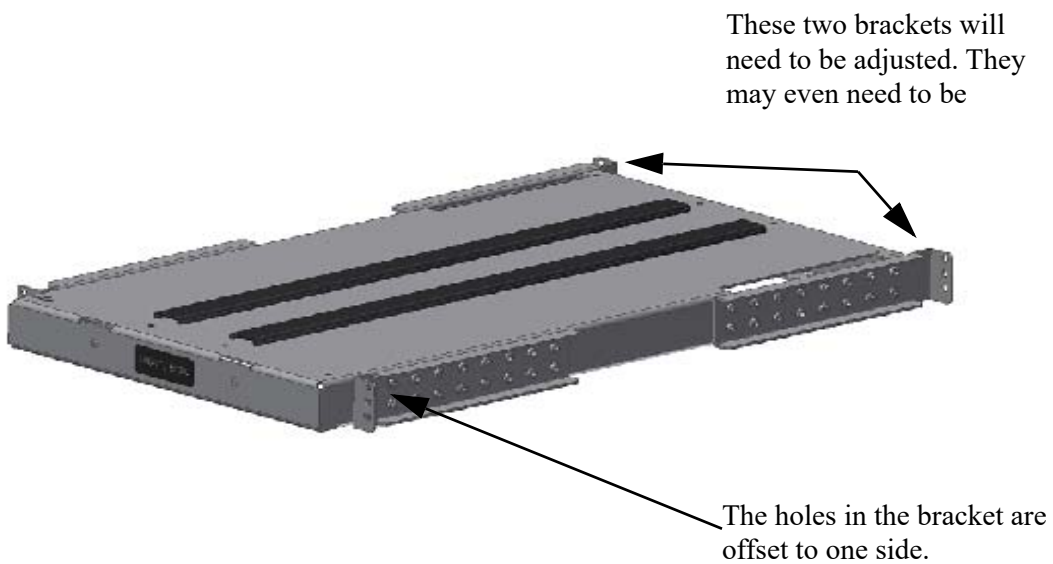
**Figure 10: Placement of Chassis in Rack**



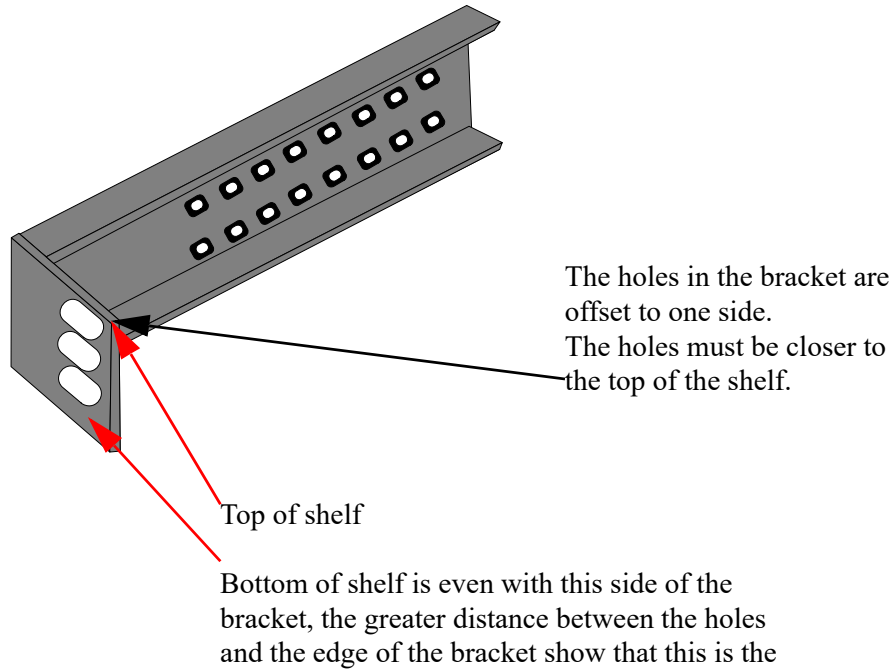
You will most likely need extra room for cable bending on the connector side of the chassis and should plan to keep the spine side as close to the rack door as possible, thus having more room for the cables.

4. Measure the distance between the vertical supports and adjust the shelf brackets according to this distance. This chassis can be installed in a rack with a distance between the vertical supports of from 65cm(25.6in.) to 80cm(31.5in.).
5. The shelf comes with the four brackets pre-installed. Two of the brackets should be loose. They may need to be removed and repositioned to meet the distance between the vertical supports of the rack.

**Figure 11: Adjustable Shelf Brackets**



**Figure 12: Top of Shelf Bracket**

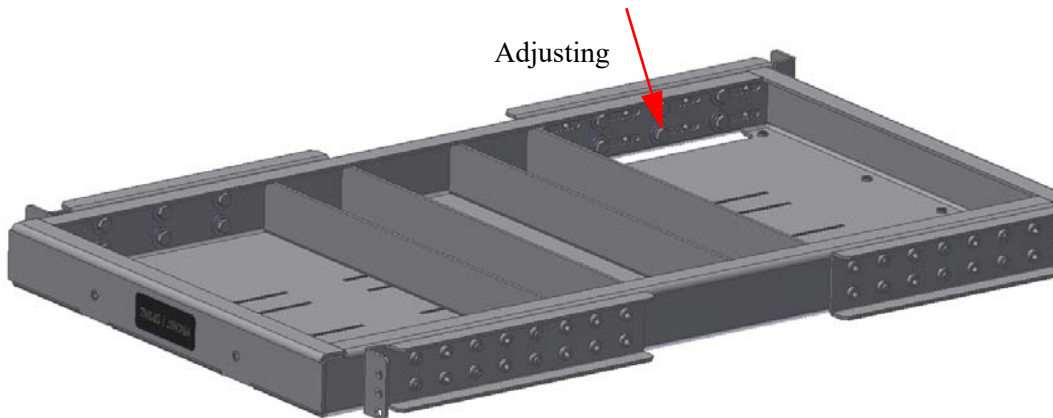


6. Move the shelf brackets on the shelf. Place the shelf bracket so that it measures slightly more than the measured distance between the vertical rack supports. Make sure that there is enough play in the bracket so that it can move to the vertical support. **Do not tighten the hex head bolts.**

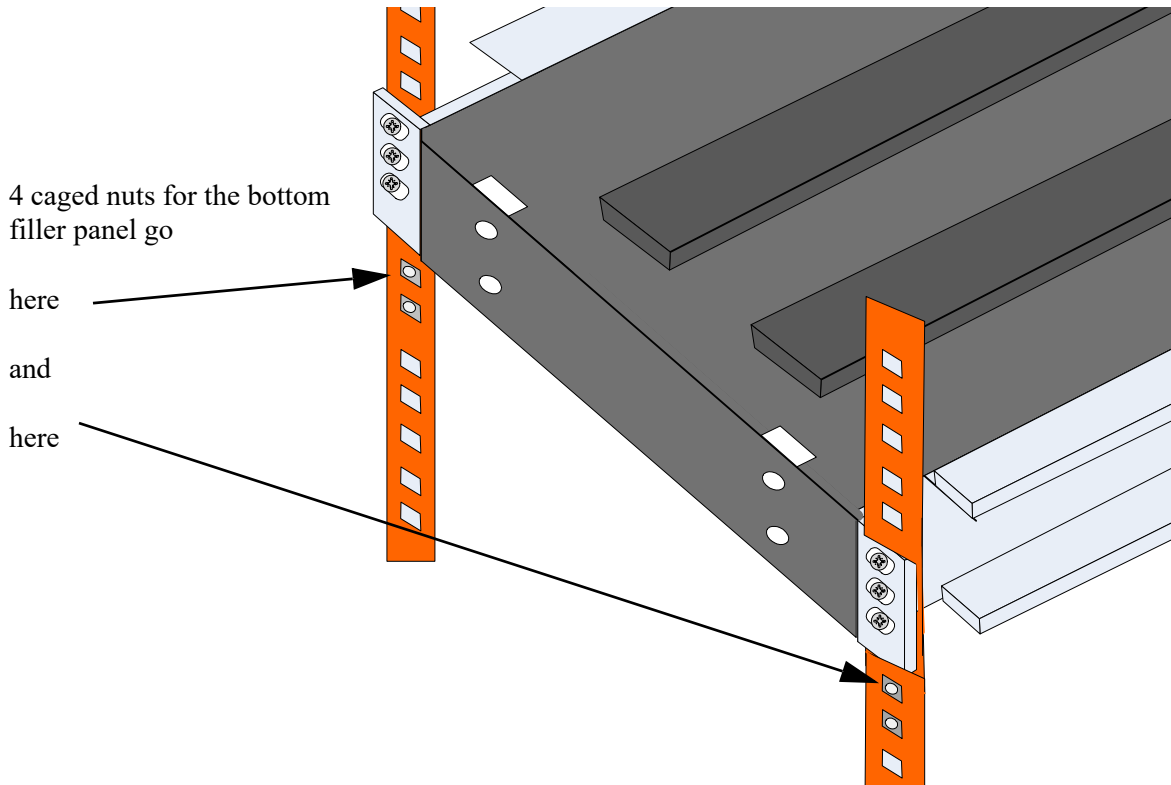


You may need to remove the brackets and reinstall them.

**Figure 13: Placing the Shelf Bracket**

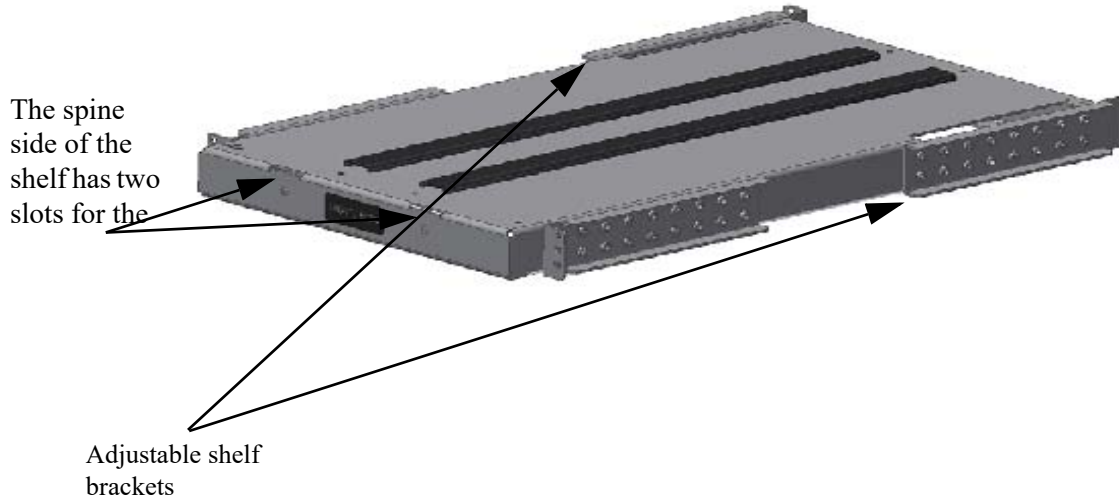


**Figure 14: Caged Nut Locations for the Shelf Brackets**



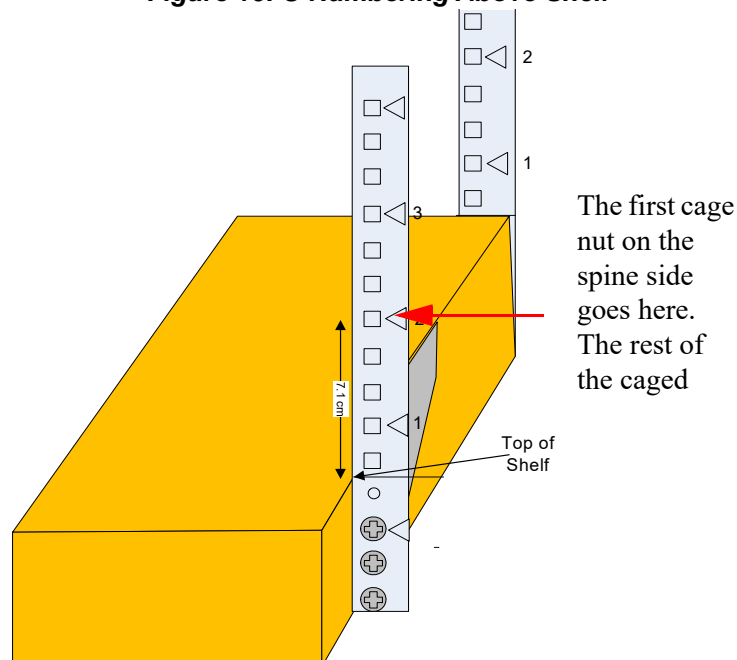
7. Insert three caged nuts into the rack for each of the four shelf brackets (the 2 brackets that are adjustable and the 2 that are fixed). Make sure that the caged nuts are all at the same height on the vertical supports.
8. Insert 4 caged nuts (two on right and 2 on the left of the spine side) for the bottom filler panel.
9. Put the Shelf into the rack and twist the shelf into place. Make sure the spine side of the shelf is closest to the rack doors. See Figure 15 to identify the spine side of the shelf.
10. Install and tighten the 12 M6 bolts into the caged nuts.

**Figure 15: Shelf Brackets**



11. Tighten the 16 hex head bolts on the adjustable brackets.

**Figure 16: U Numbering Above Shelf**



12. Place 8 caged nuts into the vertical rack support at the locations corresponding to the holes in the chassis faceplate. The holes in the faceplate start at 2U above the shelf and are spaced every 4U centered as you go up the vertical rack support. There are 4 holes on each side.

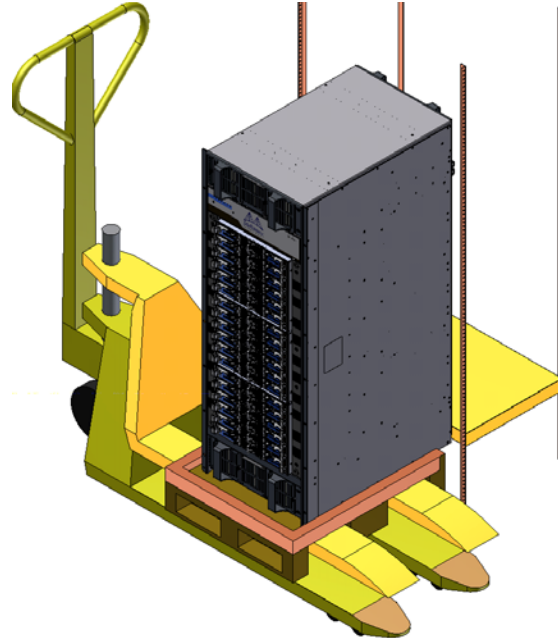
### 2.7.3.6 Inserting the Chassis



The chassis is on ball bearings and can roll easily. Be aware that the chassis can roll off of the pallet. **Should the chassis start to fall, move out of the way.** The chassis can cause grave bodily harm should it fall on or near you.

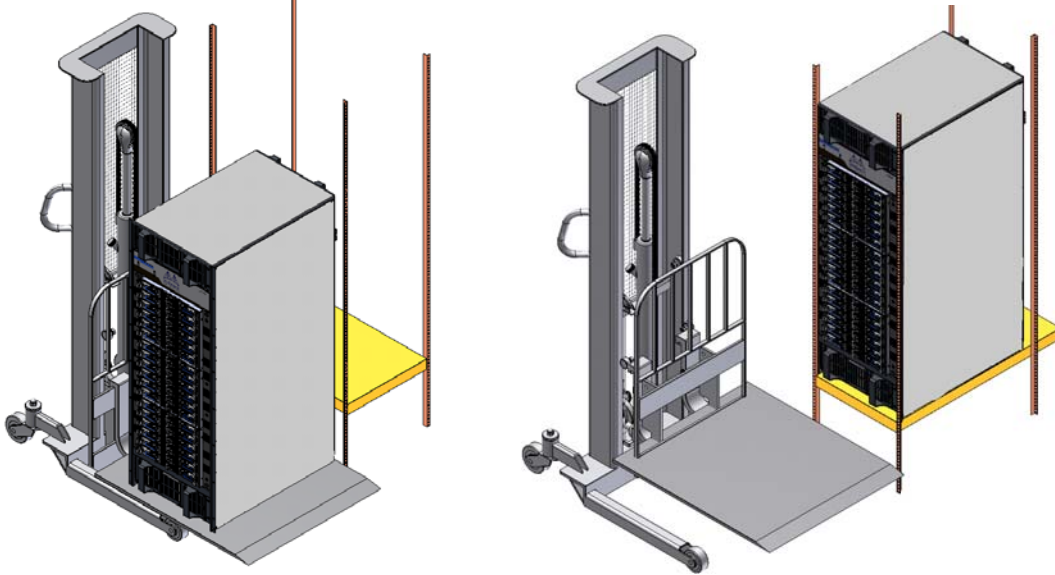
1. Put the container on the fork lift.

**Figure 17: Putting the Chassis in the Rack Using a Fork Lift**

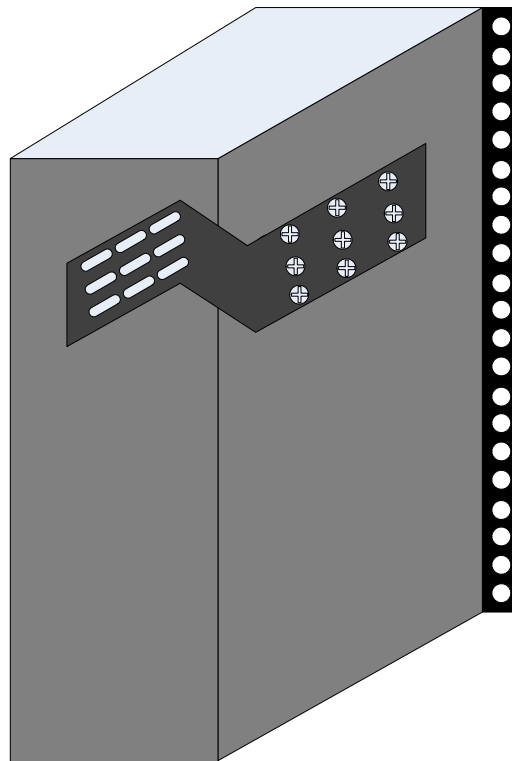


The chassis is screwed down to the pallet on both the spine side and the leaf side.

**Figure 18: Putting the Chassis in the Rack Using a Mechanical Lift**



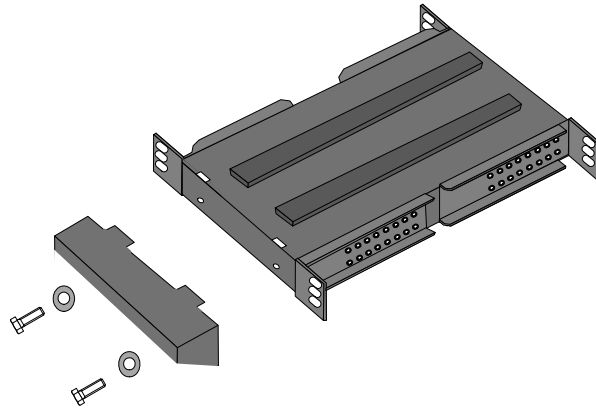
**Figure 19: Place the Upper Bracket Offset**



2. Screw on the two Upper Bracket offsets onto the chassis using six flat head screws for each offset.

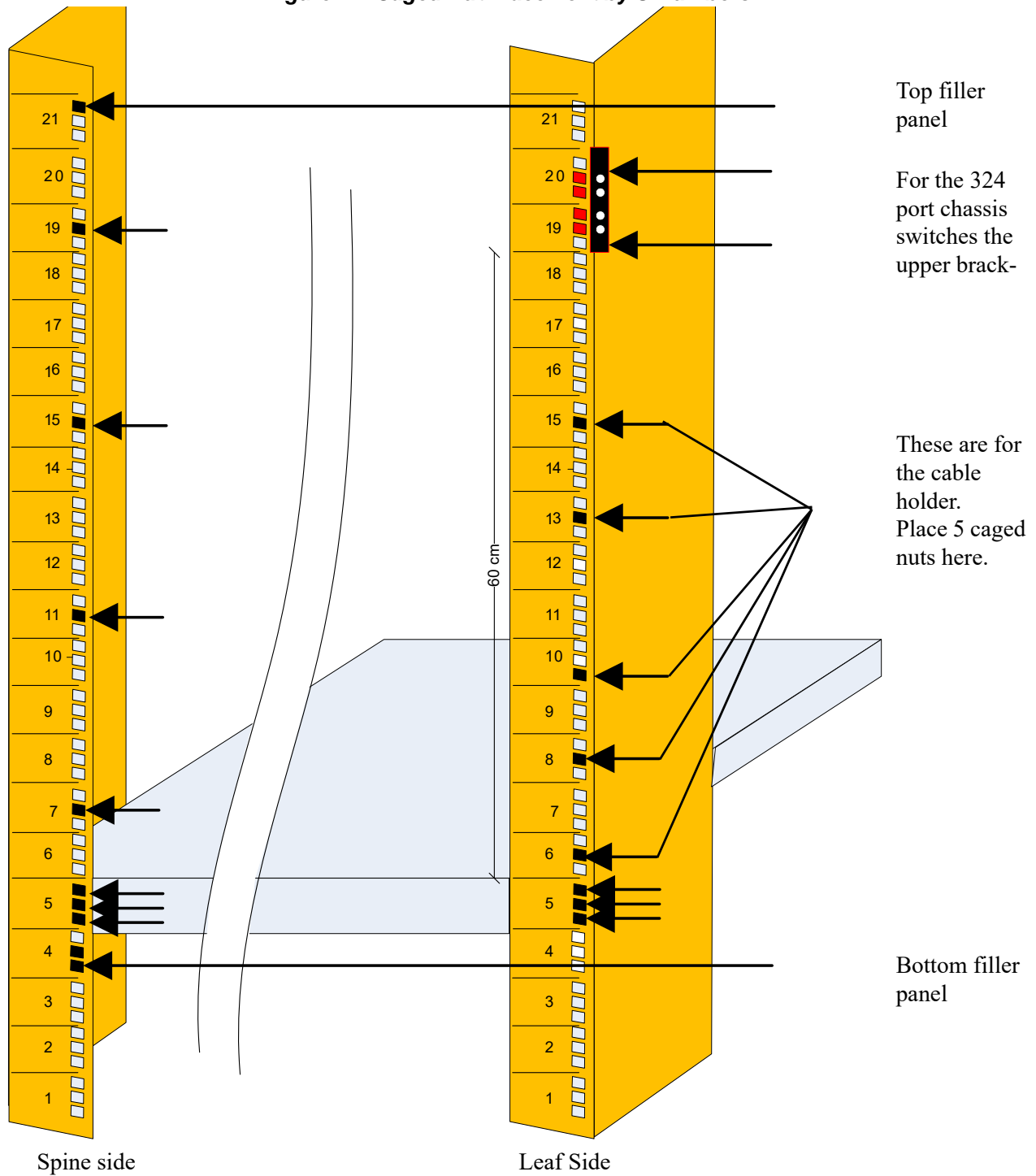


**Figure 20: Attach the Shelf Extension**

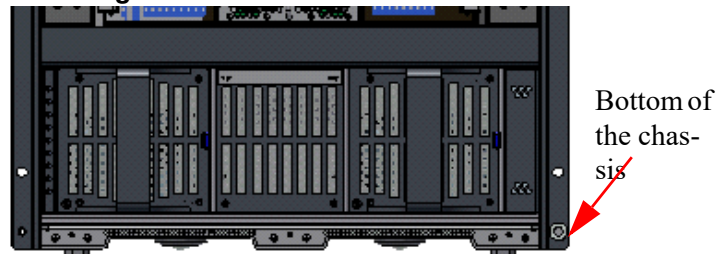


3. Screw on the shelf extension using two bolts with flat washers.
4. If you are installing the cable management system, place 10 caged nuts on the other side of the rack in the vertical supports.
5. Place caged nuts in all of the locations specified in Figure 15. The black holes show where to place caged nuts; the red holes show the location of the upper brackets on the leaf side.

**Figure 21: Caged Nut Placement by U Numbers**



**Figure 22: Location for the Lock-Down Bar**



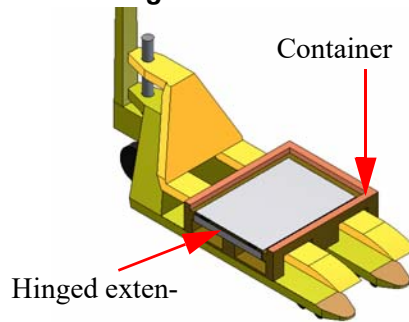
6. Unscrew both lock-down bars.



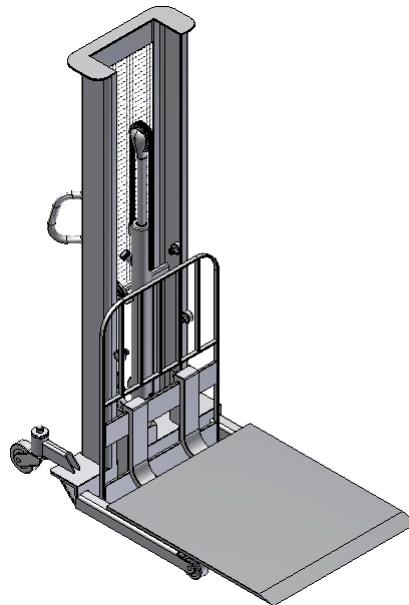
With both lock-down bars removed the chassis can roll! Be very careful that the chassis does not roll off of the pallet.

7. Place the chassis in front of the rack and as close as possible to the rack.

**Figure 23: Fork Lift**



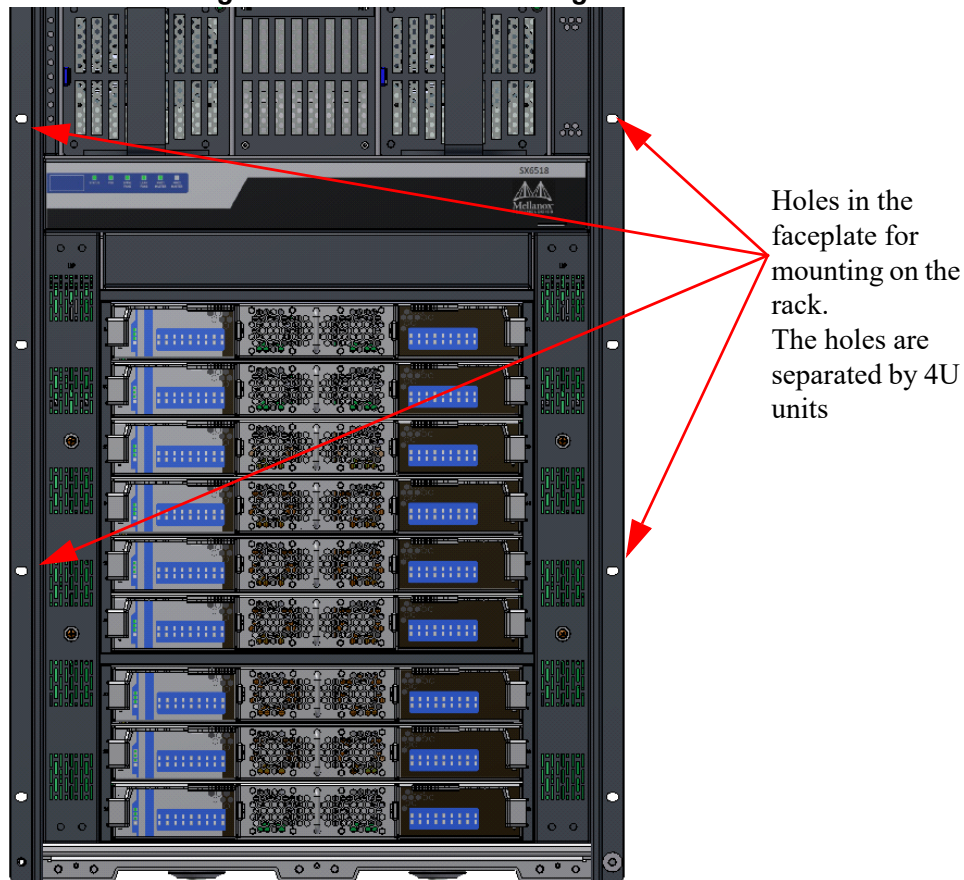
**Figure 24: Mechanical Lift**



8. Raise the chassis so that it is ~5cm above the shelf in the rack.
9. Raise the hinged extension on the container floor.
10. Lower the chassis until the hinged extension is sitting on the shelf extension.
11. Push the chassis from the container to the shelf.

Save the container pallet to remove this chassis. It will be necessary for the removal and disposal procedures.

**Figure 25: Face Plate Mounting Bolt Locations**

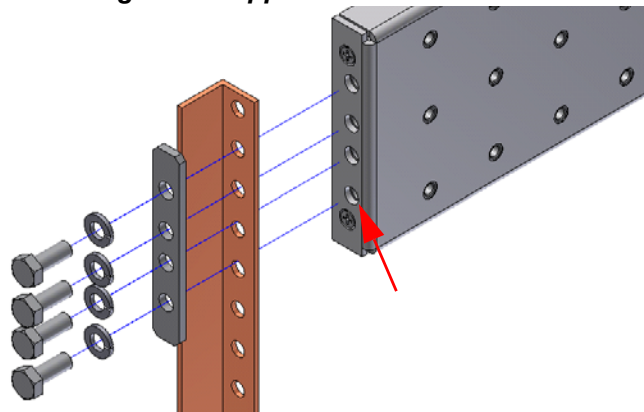


12. Slide the chassis onto the shelf and determine the location of the upper brackets, on the vertical supports on the connector side of the chassis.

Do not move the forklift away from the rack just yet.

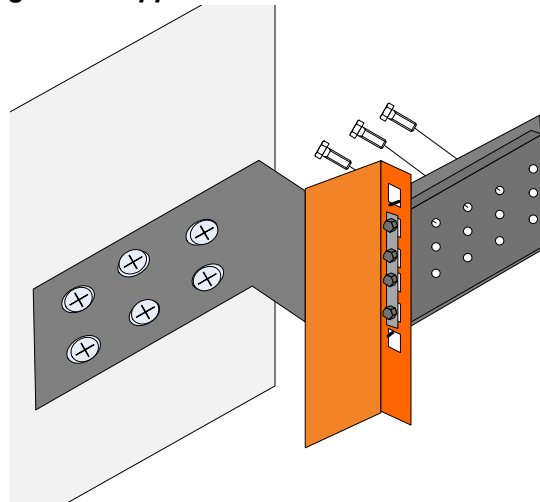
13. Confirm that the caged nuts for the faceplate are in the correct location.
14. Slide the chassis out just far enough to install the upper brackets. See Figure 26.

**Figure 26: Upper Bracket Installation**



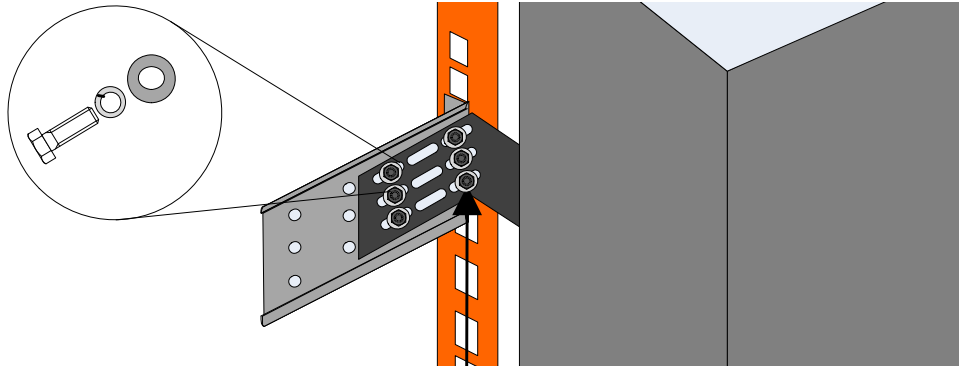
This hole is 60cm up

**Figure 27: Upper Brackets and Offset Location**



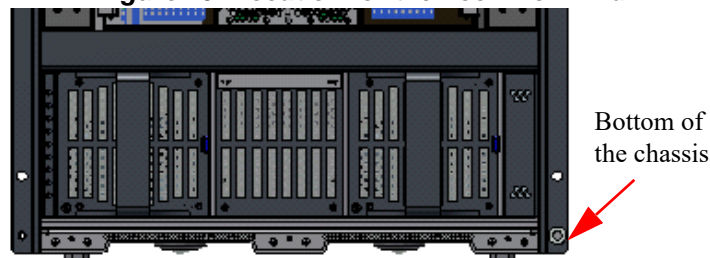
15. Screw the upper brackets onto the vertical supports and tighten in place. See Figure 27. You will need the socket wrench with both extensions to tighten these bolts.
16. Slide the chassis onto the shelf until the face plate of the chassis touches the vertical rack support.
17. Make sure the upper brackets are installed in their correct location.
18. Screw the 8 bolts through the faceplate into the caged nuts, DO NOT TIGHTEN.

**Figure 28: Offset to Upper Bracket Bolts**

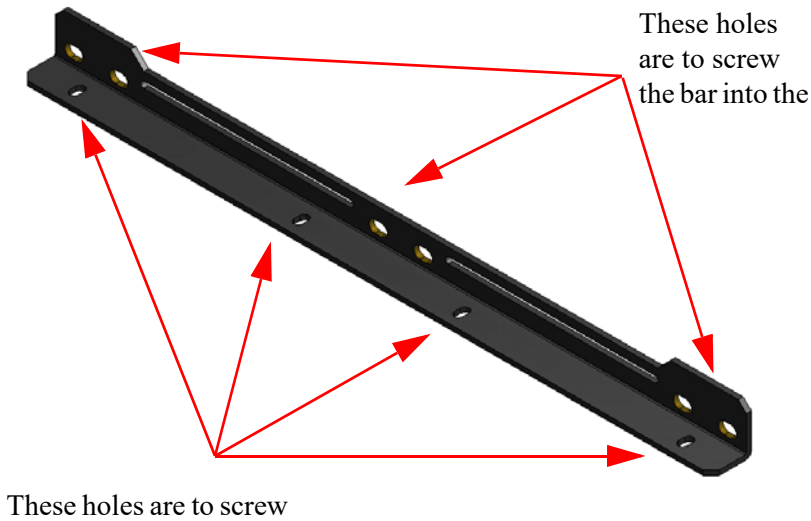


19. For each offset and upper bracket, screw six bolts through the offset into the upper bracket. See Figure 28. Use one flat washer and one lock washer for each of these bolts. **DO NOT TIGHTEN.**

**Figure 29: Location for the Lock-Down Bar**



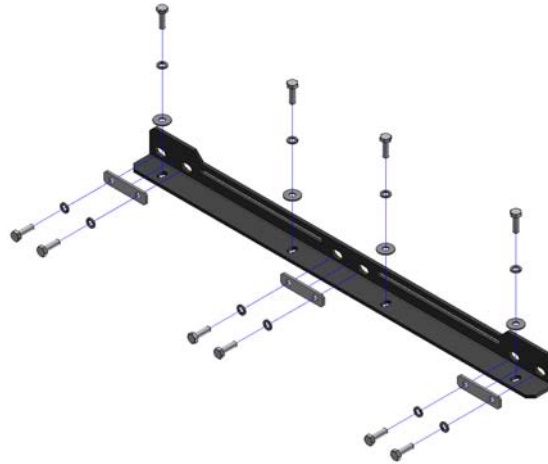
**Figure 30: Lock-Down Bar**



20. Place the front lock-down bar at the edge of the chassis and align the holes in the lock-down bar with the holes in the shelf. Screw down the lock-down bar. You will need the 10 hex head screws and washers for each lock down bar. **DO NOT TIGHTEN**

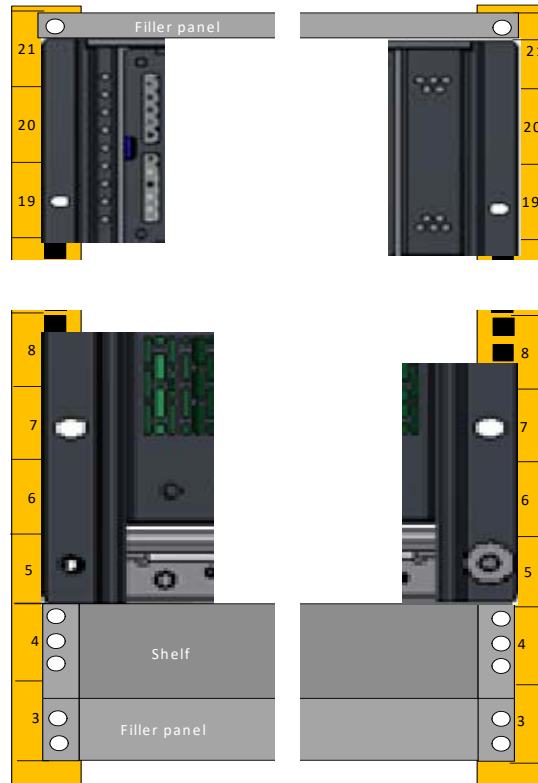
21. Screw down the second lock-down bar.

**Figure 31: Lock-Down Bars Bolt and Washer Order**



22. Remove the shelf extension and save for removal of the chassis.
23. Connect a valid ground, See [Section 2.7.5, “Ground Connections,”](#) on page 50, for detailed instructions.
24. Tighten the faceplate screws. See [Figure 24](#) on [page 43](#).
25. Tighten the upper bracket to upper bracket offset screws. See [Figure 28](#).
26. Tighten the lock down bars. See [Figure 31](#).
27. Connect the bottom filler panel below the shelf, bend facing out.
28. Connect the top filler panel directly above the top of the chassis.

**Figure 32: Spine Side with Filler Panels**



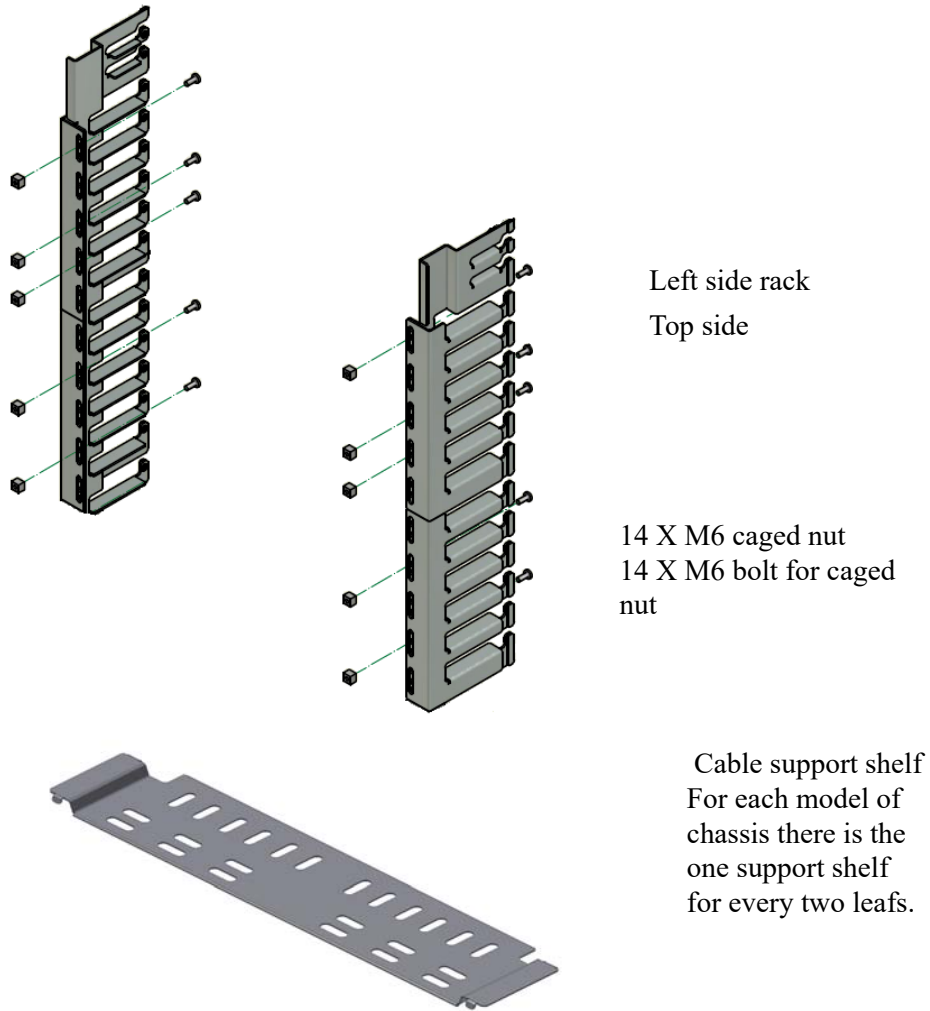
29. Go to Chapter 4, “Chassis Power Up,” on page 83 to power up the switch system.
30. Insert 2 caged nuts for the filler panel.



## 2.7.4 Installing the Cable Holder

Now is the time to install the cable holder.

**Figure 33: Cable Holder**



1. Place the cable holder next to the rack, on the connector side of the chassis, and identify the holes where the caged nuts were placed in Step 4



The cable holders should go to the outside of the vertical supports.

2. Set the bottom of the cable holder at the level of the shelf.



If the cable holder is not set properly the upper bracket will not line up with the cable holder.

3. Screw the cable holder onto the rack using the screws provided.
4. Repeat steps 1- 3 for the second cable holder.
5. Install the shelves. The cable support shelves just sit on the cable holders.
6. Use the holes in the shelves to tie down the cables individually or in bundles.



Use Velcro ties to tie down the cables. Electric cable ties are not recommended.

### 2.7.5 Ground Connections

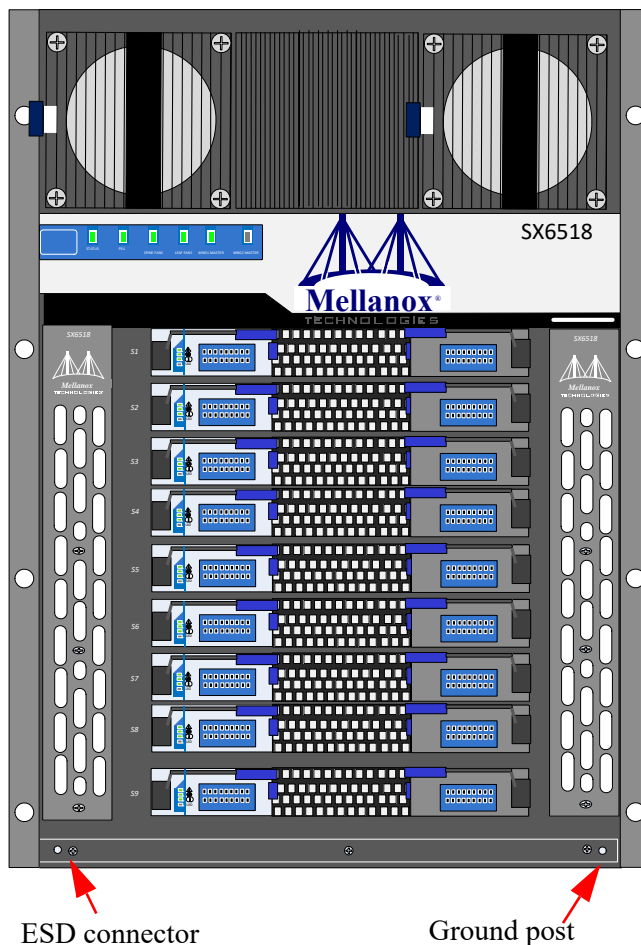
Make sure to connect the ground post to a valid electrical ground. Use a grounding lug and a ground wire of sufficient capacity to safely convey a potential discharge. The grounding post is M-6 with 1mm pitch threads. A ground wire of AWG 6 or 4mm diameter is recommended for grounding this device. The chassis is concurrently grounded through each of the PSUs. Only connect the PSU cords to properly grounded outlets. Do not rely on the PSU grounds. It is absolutely necessary to connect the grounding post. Make sure the connections are solid and permanent. If

you choose to not use the ground screw, make sure that the rack is properly grounded and that there is a valid ground connection between the chassis of the switch and the rack.



**Warning:** System grounding must comply with local electrical code.

**Figure 34: Ground Connection**



## 2.8 Power Connections

The switch includes integrated hot-swap power supplies which support up to 6 load-sharing 1000W or 1670W supply units. The slots for the power supply units (PSUs) are on the spine side. The left side has odd numbered PSUs and the right side has even numbered PSUs. Each PSU has a dedicated AC inlet. This design enables the optional use of separate main and backup AC feeds. The input voltage is Autorange, 100-240 VAC, 50Hz or 60Hz. The output voltage for the PSUs is 48V. The power cords should be standard 3-wire AC power cords including a safety ground.

## 2.8.1 Connecting to an AC power source

Connecting the system to an AC source requires PDUs with appropriate number of C13 sockets. The system is supplied with a standard C14 to C13 power cords. The number of supplied cords matches the number of PSUs on the switch system.



Use the cords provided by Mellanox for a reliable power connection to the system.

## 2.8.2 Powering Up the Switch Platform



Make sure that the power cords are compatible with your outlets. Power cords for different countries can be ordered from Mellanox.

The chassis in N+1 mode must be started with a full complement of PSUs, thereafter it can run on one less than the total number of PSUs. This final PSU is redundant and allows for hot swapping a PSU should one fail. Connecting the PSUs to different AC lines provides AC failover protection.

When using the 1670W PSUs, the minimum complement of power supply units to start the chassis is 3 and the chassis will continue to run at full capacity with only 3 PSUs.

The system should continue to run and allow a hot swap of a defective PSU. Should there not be enough power to keep all of the leafs running, MLNX-OS® may power down some leafs. If this happens it may be necessary to reboot the chassis once the defective PSU has been replaced. Two simple ways to reboot is to use the reboot command in the CLI or reboot through the Web GUI.

The power system will divide the current consumption by the number of working PSUs. Should one of the PSUs fail, the total current consumption will then be divided by the remaining working PSUs. When the failed PSU is hot swapped the new PSU will ramp up and pass its share of current, so that the total current is always divided by the number of working PSUs.

1. Plug in the power cords to the PSUs.
2. Plug the other end of the power cords into grounded outlets.



Make sure that the outlets and circuits will not be overloaded. Spread out the load over at least two or three circuits or use a 3 phase circuit.

**Figure 35: Multiple Power Inlets – Electric Caution Notification**

Risk of electric shock and energy hazard. The PSUs are all independent.

Gefahr des elektrischen Schocks. Entfernen des Netzsteckers eines Netzteils spannungsfrei. Um alle Einheiten spannungsfrei zu machen sind die Netzstecker aller Netzteile zu entfernen

Risque de choc et de danger e’lectriques. Le de’branchement d’une seule alimentation stabilise’e ne de’branch uniquement qu’un module “Alimentation Stabilise’e”. Pour isoler completement le module en cause, Il faut

Disconnect all power supplies to ensure a powered down state inside of the

3. Check the Status LEDs on all of the management modules and confirm that all of the LEDs show status lights consistent with normal operation.



Any yellow or red status LEDs on any of the management modules is cause for concern and must be dealt with immediately.

4. Check that none of the LEDs on the spines are yellow.



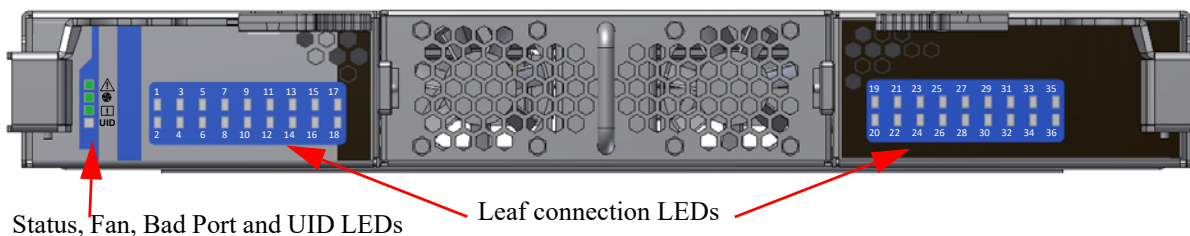
It can take up to 5 minutes to boot up the system. Turn off the system if any LEDs remain red for more than 5 minutes.

5. Check that the leaf status LEDs, fan status LED, and spine status LED in the spines are all green.



The maximum number of connections from each leaf is 2. If the (number of leaves x the maximum number of connections per leaf) is less than 36 then some of the leaf to spine connection LEDs may be OFF.

**Figure 36: Spine Module**



## 2.9 InfiniBand QSFP Cable Installation

The switch uses industry standard QSFP InfiniBand cables which are available from Mellanox Technologies. The Mellanox proprietary QSFP cables support full 56+56Gb/s (FDR), 40+40Gb/s (FDR10), 40+40Gb/s (QDR), 20+20Gb/s (DDR) and 10+10Gb/s (SDR) bidirectional wire speed of the switch ports. All InfiniBand QSFP connections are made to the leaf boards. Each

leaf has 18 InfiniBand QSFP connectors in two rows, which are numbered 1-18. See Section 3.1.6 for port numbering.



If maximum cable lengths are exceeded data transfer will be reduced and the bit error rate will increase.



To raise link at FDR (56Gb/s) with 3rd party FDR cables, managed switch systems must be programmed with management software MLNX-OS 3.3.4304 or higher, and unmanaged switch systems need SwitchX firmware version 9.2.6000 or higher.



FDR and FDR10 are only guaranteed to work with approved Mellanox Cables.

All cables can be inserted or removed with the unit powered on. To insert a cable, press the connector onto the port receptacle until the connector is firmly seated. The orange LED indicator above the port will light when the physical connection is established (when both ends of the cable are properly connected to working devices). Allow 15 seconds for link to get up. To remove, disengage the lock and slowly pull the connector away from the port receptacle.



For a valid physical connection both ends of the cable must be connected to working devices.



Take care to not impede the air flow through the ventilation holes next to the InfiniBand ports. Use cable lengths which allow routing horizontally around to the side of the chassis before bending upward or downward in the rack.

### 2.9.1 Supported Approved Cables

For a list of approved cables for this switch see the Mellanox approved cable list.

[http://www.mellanox.com/related-docs/user\\_manuals/Mellanox\\_approved\\_cables.pdf](http://www.mellanox.com/related-docs/user_manuals/Mellanox_approved_cables.pdf)

### 2.9.2 Cable Power Classes

Chassis and switches need to be able to dissipate the heat generated by high power I/O cables and modules. The Mellanox SX65xx series chassis are rated for cables up to class 2 as per the SFF committee classification ([SFF-8436.PDF](#)).

See <http://www.mellanox.com/content/pages.php?pg=cables> for the cable class rating of Mellanox cables.

## 2.10 Hot Swap Insertion and Extraction

Before starting any procedure on the SX6518 switch system, put an ESD prevention wrist strap on your wrist and connect to the SX6518 chassis.



Do NOT mix replacement parts based on different generations of chip.

Do not install InfiniScale IV based replacement parts within a SwitchX® based chassis and vice versa. All Replacement modules must be consistent with the Chassis family and switch chip generation.



When hot-swapping any of the units, it is necessary to wait 1 minute after removing the defective part before inserting the new part. This is necessary so that the management module will start a new cycle checking through the leafs and spines for the FW versions.

This switch platform supports hot swap capabilities for the parts listed below.

- Power supply units
- Leaf boards
- Spine boards
- Leaf fan module
- Spine fan module
- Management modules

### 2.10.1 Power Supply Units

The 1000W power supplies deliver 1000W at 48V. The input to each of these power supplies requires 1176.5W in order to output 1000W.

The 1670W power supplies deliver 1670W at 48V. The input to each of these power supplies requires 1882.4W in order to output 1670W.

For N+2 configuration PSUs (Power Supply Unit) can be extracted without bringing down the system.

For N+N configuration up to half of the PSUs can go down and the system will continue to run.

The power required to run the switch system is equally divided between all of the working PSUs.

#### 2.10.1.1 Extracting and Inserting the Power Supply Unit

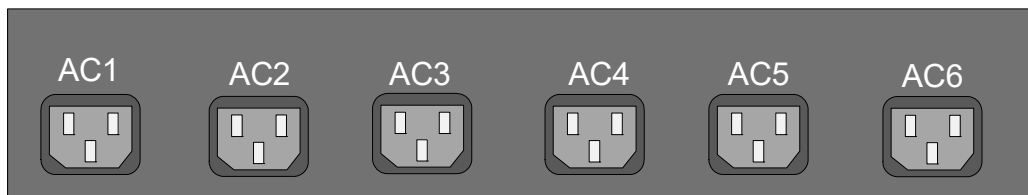
With all of the 1000W power supplies installed, the system is in N+1 redundant configuration.

With all of the N+N 1670W power supplies installed, the system is in N+N redundant configuration, half of the PSUs may be extracted without bringing down the system.

➤ **To extract a PSU:**

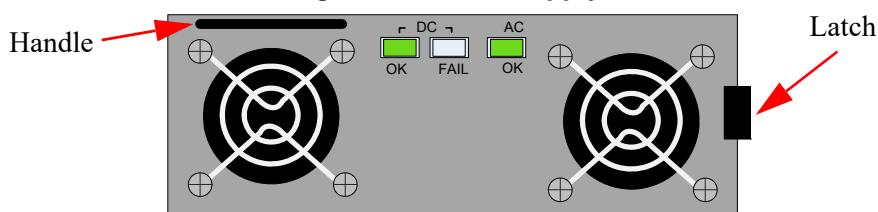
1. Determine which AC connector on the connector side of the chassis corresponds to the defective PSU.
2. Remove the power cord from the power supply unit. Note which power cord it is according to the AC numbering.

**Figure 37: Power Cord Numbering**



3. On the spine side of the chassis, remove the cover to the power supply unit for the non-working PSU. Odd numbered PSUs are on the left side and even numbered PSUs are on the right side facing the spines. There are four phillips head screws for the cover plate.

**Figure 38: Power Supply**



4. Grasping the handle with one hand, push the black latch release while pulling the handle outward. As the PSU unseats, the PSU status indicators will turn off.
  5. Remove the PSU.
- **To insert a PSU:**
1. Make sure the mating connector of the new unit is free of any dirt and/or obstacles.
  2. Insert the PSU by sliding it into the opening until a slight resistance is felt.
  3. Continue pressing the PSU until it seats completely. The latch will snap into place confirming the proper installation.
  4. Insert the power cord into the supply connector on the other side of the chassis.
  5. Replace the cover over the PSUs.



The green indicators should light. If not, extract the PSU and re-insert it again.

### 2.10.2 Leaf Boards



Do NOT mix replacement parts based on different generations of chip. Do not install InfiniScale IV based replacement parts within a SwitchX® based chassis and vice versa. All Replacement modules must be consistent with the Chassis family and switch chip generation.

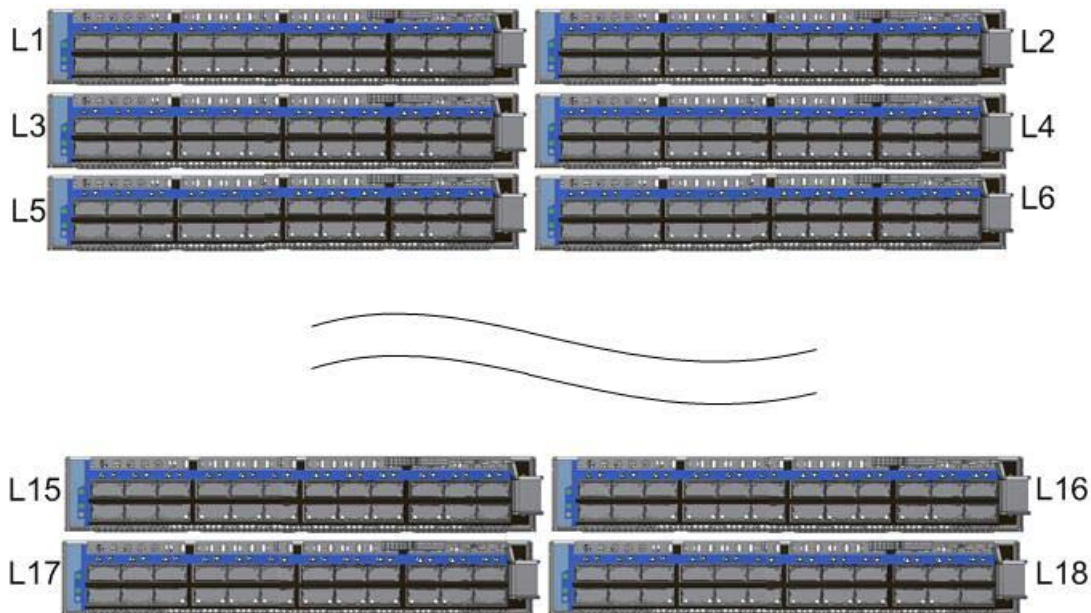


When hot-swapping any of the units, it is necessary to wait 1 minute after removing the defective part before inserting the new part. This is necessary so that the management module will start a new cycle checking through the leafs and spines for the FW versions.



The leaf boards are numbered from top to bottom, with corresponding numbers displayed to the outside of the leafs vertically along the side panel.

**Figure 39: Leaf Board Numbering**



### 2.10.2.1 Extracting a Leaf Board

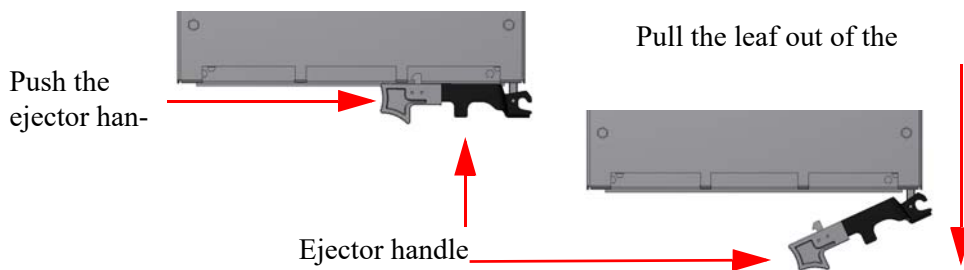
Each leaf board has an ejector handle that locks the board in place and serves as a lever for seating or extracting (see Figure 40).

1. Run the shut down command "no power enable <module>". For example to shut down leaf 16 run the command below.

```
switch [master] (config) # no power enable L16
```

2. Disconnect all cables connected to the leaf.
3. Push the ejector handle to unlock the ejector from the chassis.
4. Open the ejector until it is 45 degrees from the leaf.

**Figure 40: Ejector Handle**



5. Pull out the module half-way through the guiding rails using the ejector handle.
6. Lock the ejector handle.

7. Hold the body of the leaf on both sides and remove it from the chassis.

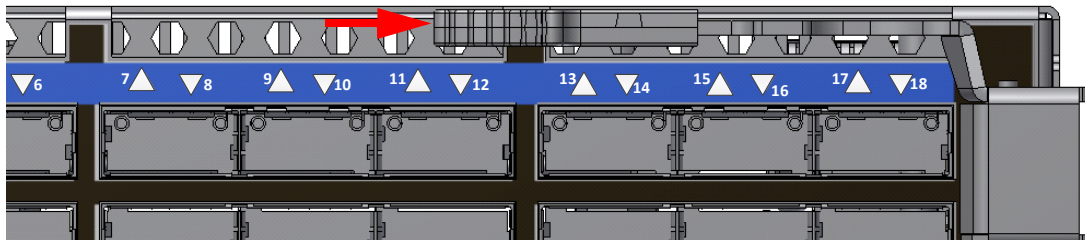


The board is short, therefore do not let go of it while sliding it out.

**Figure 41: Leaf Release**

Push here to release the ejector handle

Pull the ejector handle to remove the



### 2.10.2.2 Inserting a Leaf Board

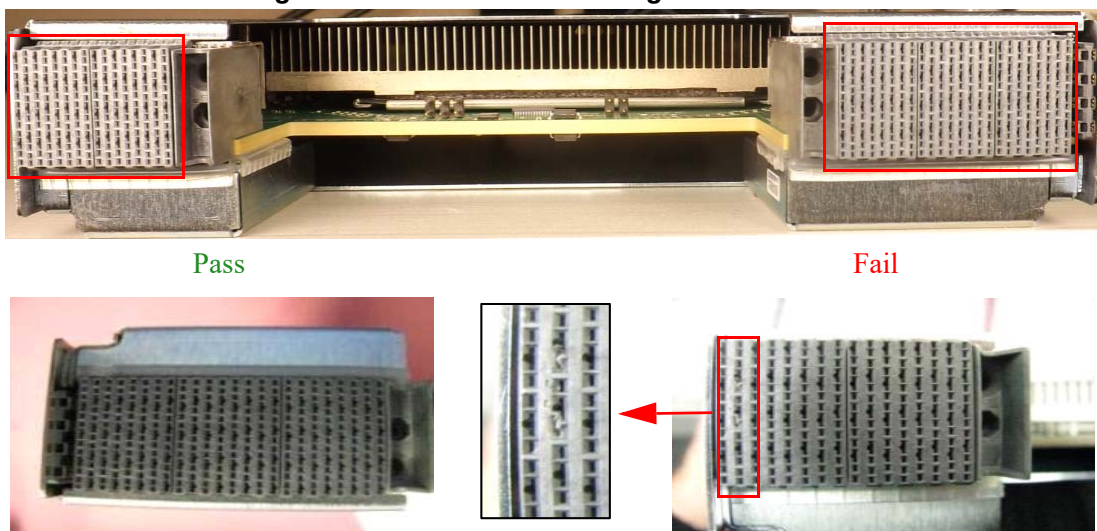


When hot-swapping any of the units, it is necessary to wait 1 minute after removing the defective part before inserting the new part. This is necessary so that the management module will start a new cycle checking through the leafs and spines for the FW versions.

To insert the leaf board:

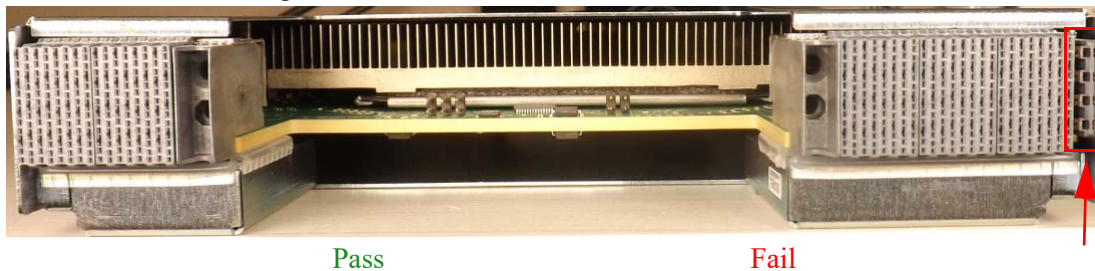
1. Check for foreign objects in or mechanical damage to the chassis leaf slots.
2. Check leaf mechanics for any noticeable damage.
3. Check back signal connectors' integrity. Look for any broken signal dividers or any deviations from the pass criterion shown in Figure 42.

**Figure 42: Intact vs Defected Signal Connectors**



4. Check power connector's integrity. Look for any damage on the power connector casing or blades damage, or any deviations from the pass criterion show in Figure 43.

**Figure 43: Intact vs Defected Power Pin Holders**



5. Start with the ejector handle fully open; that is, at 45 degrees to the front panel of the leaf.
6. Holding the leaf by its sides, carefully set the leaf board into the chassis.
7. Applying equal pressure on both sides of the leaf board, slowly slide the board into the chassis until the ejector handle reaches the vertical bar.



Do not apply excessive force to slide in the leaf board. If you feel resistance, remove the leaf board and double check both the chassis and leaf for any damage.

8. Catch the hook onto the vertical bar of the chassis and push the ejector handle shut.
9. Lock the ejector handle onto the board.

### 2.10.3 Spine Boards



Do NOT mix replacement parts based on different generations of chip. Do not install InfiniScale IV based replacement parts within a SwitchX® based chassis and vice versa. All Replacement modules must be consistent with the Chassis family and switch chip generation.



When hot swapping any of the units, it is necessary to wait 1 minute after removing the defective part before inserting the new part. This is necessary so that the management module will start a new cycle checking through the leafs and spines for the FW versions.

Each spine has a pair of ejectors that lock the board in place and serve as levers for seating or extracting (see Figure 45).

Management board #1 is connected to spine board #1, and management board #2 is connected to spine board #2. **When a slave management board is not installed or not working, the spine board connected to the master management board cannot be hot-swapped.** All of the spine boards can be hot-swapped when two management boards are installed and working.



When more than one spine slot is empty always insert the lowest spine board first, then work your way up.



If you need to replace the bottom spine and it does not go in, try removing one or two spines above it and then insert the spines from the bottom up.

#### 2.10.3.1 Extracting a Spine Board



When a slave management board is not installed or not working, hot-swapping the spine board connected to the master management board will cause the chassis to crash.



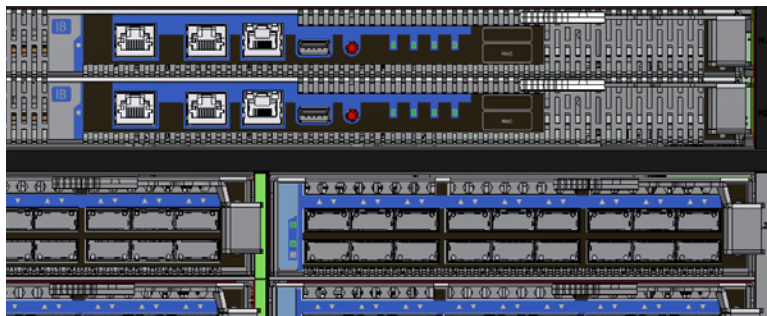
Neither the CLI nor the GUI management tools will allow you to shut down spine #1 or spine #2, as the management modules are connected to the chassis components through these spines.

#### Extracting Spine Board #1 or #2

Spine board #1 is connected to management board #1 and spine board #2 is connected to management board #2.



**Figure 44: Management Module Numbering**



MNG1 management module #1  
MNG2 management module #2



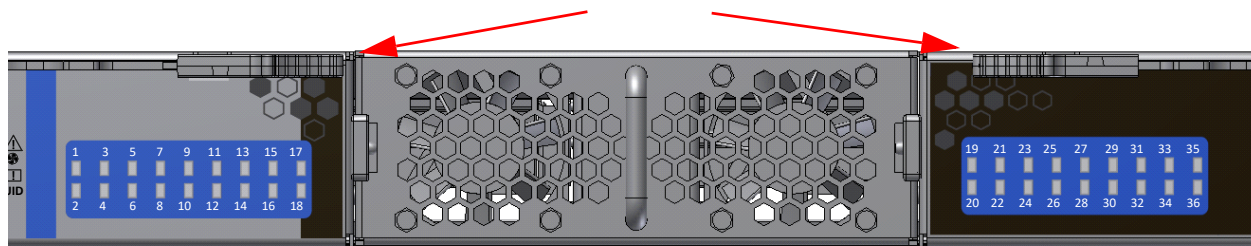
Removing spine #1 causes management module #1 to reset.  
Removing spine #2 causes management module #2 to reset.



**Warning:** If the spine you want to hot swap is connected to the **master** management module the management module will **reboot** when you take out the spine.  
**If you have only one management module the chassis will crash!**

**Figure 45: Spine Board Extraction**

Pull the ejector handles out to remove the spine.



If you need to hot swap spine #1 or spine #2:

1. Check to see if the spine you need to remove is connected to the master management module. See Figure 44.



If you have only one management module, the chassis will crash!

2. Follow the steps in Section below.

**Extracting Spine Boards Except #1 or #2**

1. Run the shut down command "no power enable <module>". For example to shut down spine 06 run the command below.

```
switch [master] (config) # no power enable S06
```

2. Push outward on the ejector handles to unlock the ejectors from the chassis.
3. Open the ejectors until they are at a 45 degree angle from the module.



Do not use the fan FRU handle to extract the spine board.

4. Pull out the module half-way through the guiding rails using both ejectors.
5. Lock the ejector handles.
6. Hold the body of the board on both sides and remove it from the chassis.

### 2.10.3.2 Inserting a Spine Board

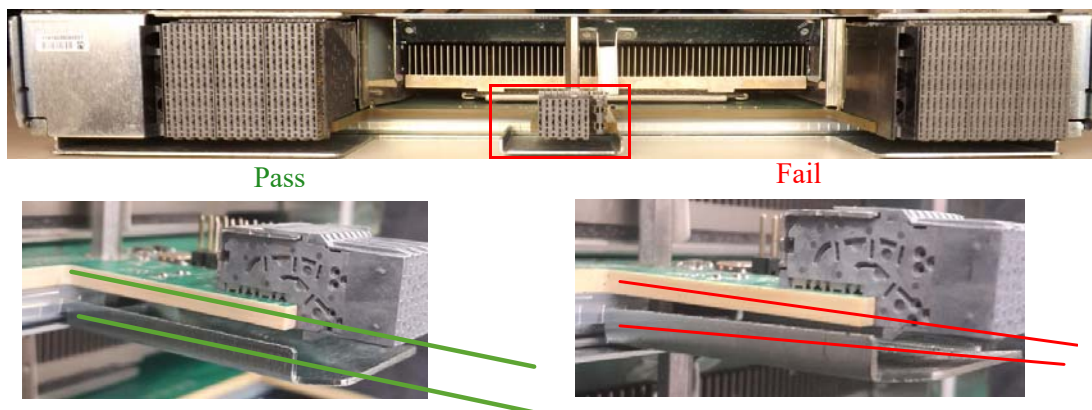


When hot-swapping any of the units, it is necessary to wait 1 minute after removing the defective part before inserting the new part. This is necessary so that the management module will start a new cycle checking through the leafs and spines for the FW versions.

To insert a spine board:

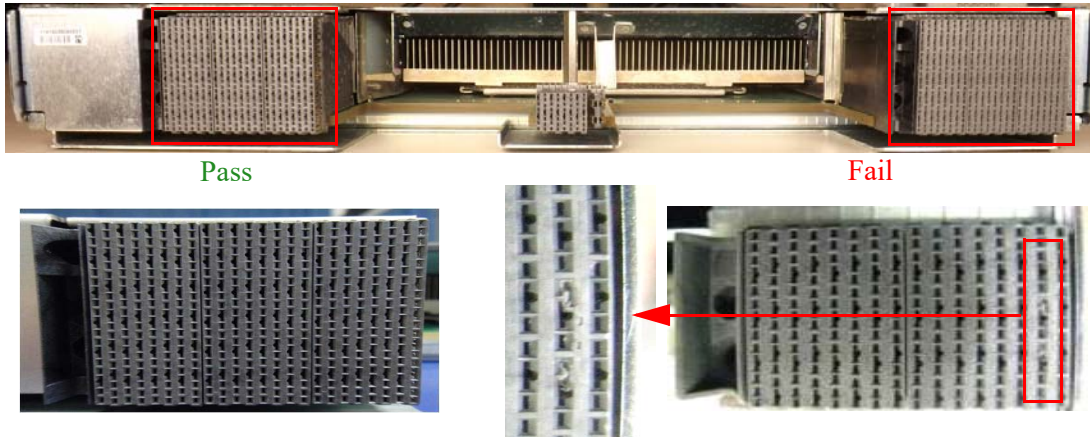
1. Check for foreign objects in or mechanical damage to the chassis spine slots.
2. Check spine mechanics for any noticeable damage or deviations from the pass criterion shown in Figure 46.

**Figure 46: Intact vs Defected Mechanics**

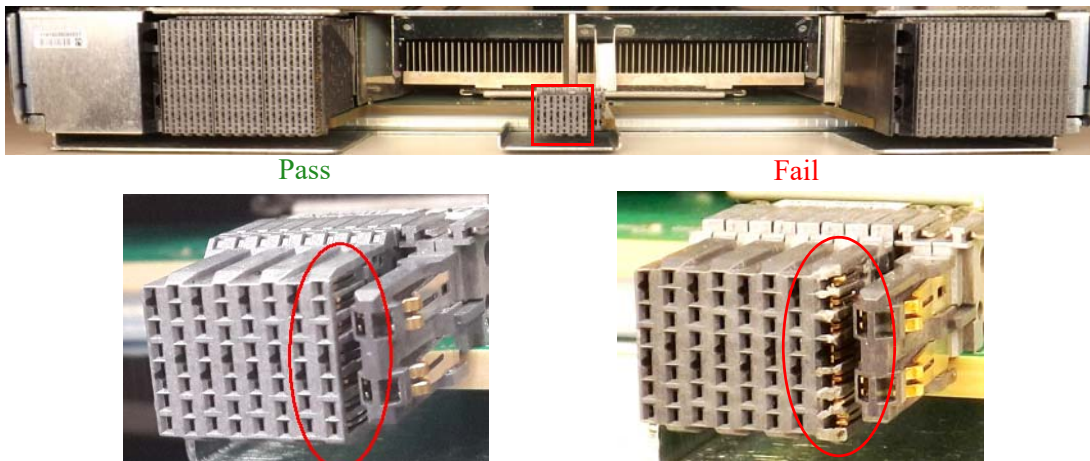


3. Check back signal connectors' integrity. Look for any broken signal dividers or any deviations from the pass criteria shown in Figure 47 and Figure 48.

**Figure 47: Intact vs Defected Side Signal Connectors**

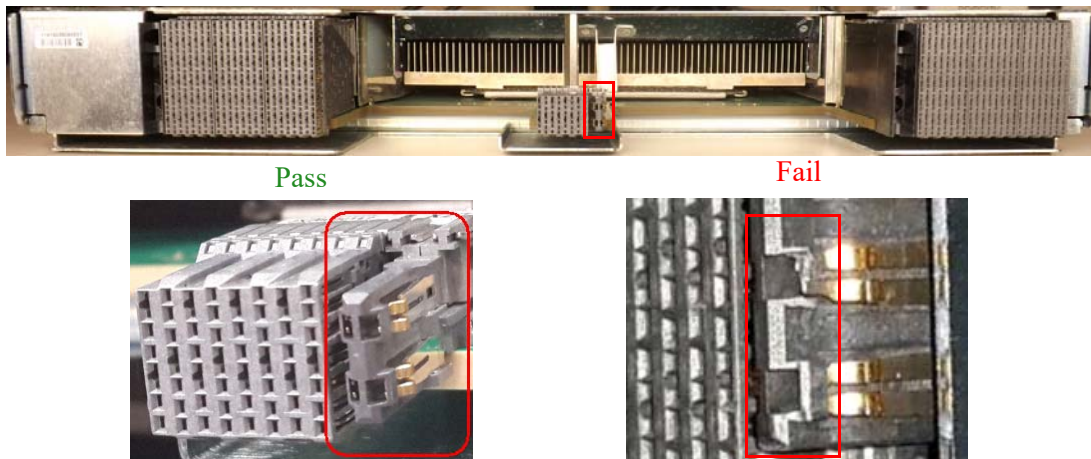


**Figure 48: Intact vs Defected Middle Signal Connectors**



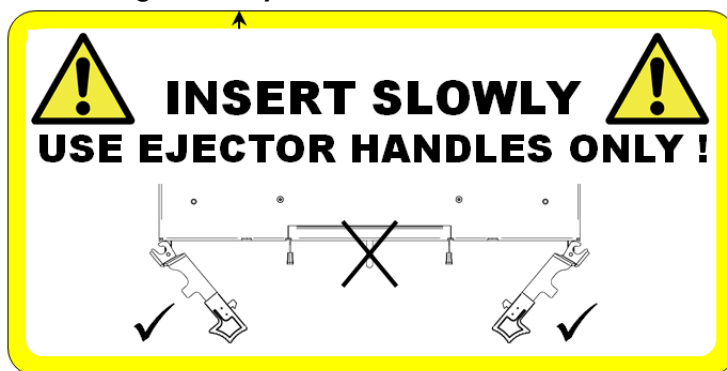
4. Check power connector's integrity. Look for any damage on the power connector casing or blades damage, or any deviations from the pass criterion shown in Figure 49.

**Figure 49: Intact vs Defected Power Pin Holders**



5. Note the following sticker placed on the top of the spine board.

**Figure 50: Spine Board Insertion Caution**



6. Start with the ejector handles fully open; that is, at 45 degrees to the front panel of the spine.



Do not use the fan FRU handle to insert the spine board.

7. Holding the spine by its sides, carefully set the spine board into the chassis.
8. Using only the ejector handles, slowly slide the board into the chassis until the hooks reach the vertical bar.



Do not apply excessive force to slide in the spine board. If you feel resistance, remove the spine and double check both the chassis and spine for any damage.

9. Catch the hooks onto the vertical bar of the chassis and push the ejector handle shut.



10. Lock the ejector handles onto the board.

### 2.10.4 Fan Modules

There are four fan modules on the chassis for the leafs. They are located on both sides of the chassis; two on the leaf side corners and two on the spine side. When a fan module is not functioning the status LED on the fan will light up.

Each spine has an individual fan module that contains two individual fans. Should a single fan fail the Fan Status LED on the spine and the S. Fan LED on the management module will light, indicating the necessity to replace the fan module. Air flow through the spines is independent of the air flow through the leafs.



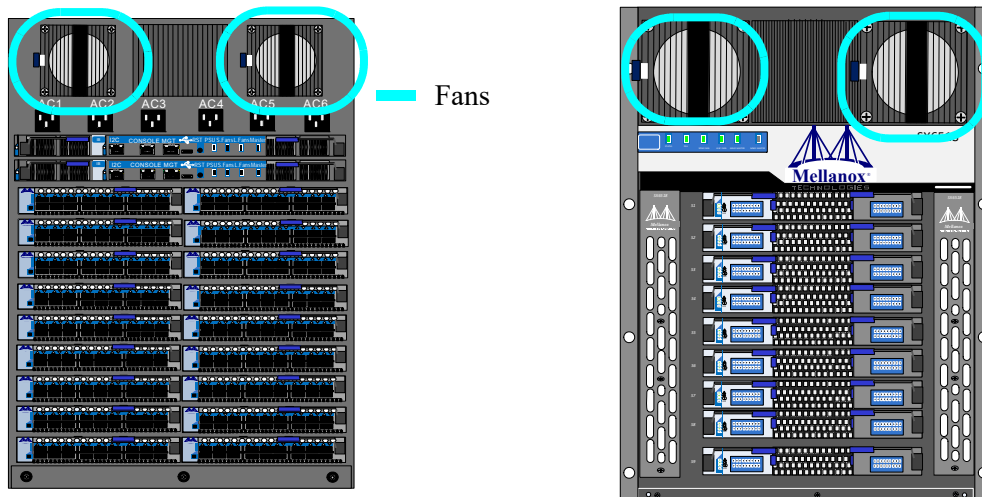
There are two different fan modules for the chassis. These fans have different model numbers and are not interchangeable. The fans on the leaf side of the chassis are MTF005001, whereas the fans on the spine side of the chassis are MTF005002.

#### 2.10.4.1 Leaf Fan Module

There are four leaf fan modules. Two leaf fan modules are found on the leaf side and two leaf fan modules are found on the spine side.

The leaf side fans are not interchangeable with the spine side fans. Air flow through the leafs is independent of the air flow through the spines.

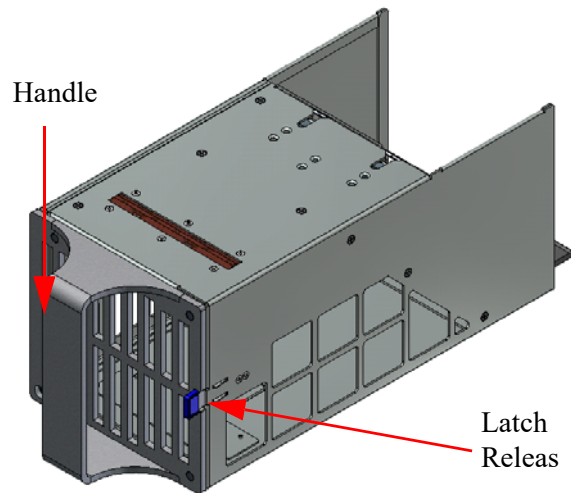
**Figure 51: Leaf Fan Locations on the Chassis**



#### Extracting the Leaf Fan Module

1. Push and hold the blue latch release. See Figure 52.
2. Slowly pull out the fan module using the handle.

**Figure 52: Leaf Fan Module Extraction**



**Inserting the Leaf Fan Module**



When hot-swapping any of the units, it is necessary to wait 1 minute after removing the defective part before inserting the new part. This is necessary so that the management module will start a new cycle checking through the leafs and spines for the FW versions.

1. Make sure the fan module is oriented correctly top side up. Confirm that the location of the connector in the chassis will line up with the connector in the fan module.
2. Slowly slide in the new leaf fan module.



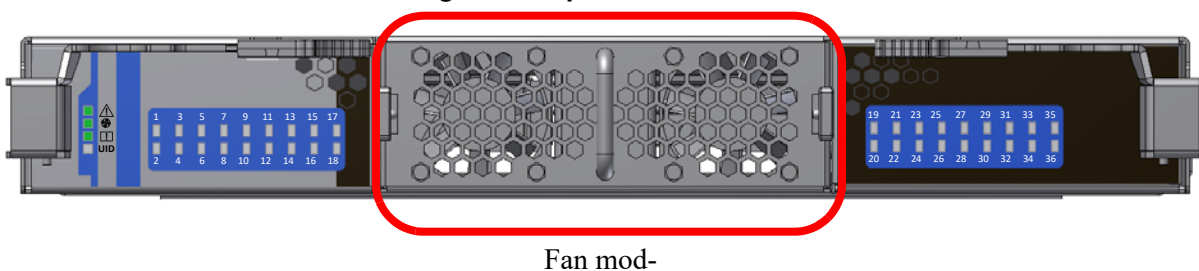
If the fan module stops before it goes in all of the way it is inserted incorrectly or it may be for the other side of the chassis!

3. Push the fan module until the latch engages.
4. Make sure that the green leaf LED on the module comes on (indicating that fan is running).

**2.10.4.2 Spine Fan Modules**

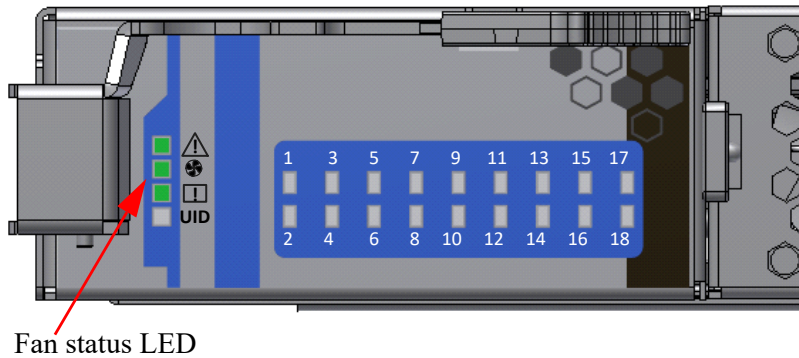
Each spine module has a fan module with two individual fans built in. When a fan module is not functioning the Fan Status LED on the spine will light up.

**Figure 53: Spine Fan Module**



When a fan module is removed the indicator light will reset.

**Figure 54: Fan Status LED on the Spine Module**



### Extracting the Spine Fan Module

1. Push the two blue latch buttons together while pulling the fan module out.

### Inserting the Spine Fan Module



When hot-swapping any of the units, it is necessary to wait 1 minute after removing the defective part before inserting the new part. This is necessary so that the management module will start a new cycle checking through the leafs and spines for the FW versions.

1. Make sure the fan module is oriented correctly top side up. Confirm that the location of the connector in the chassis will line up with the connector in the fan module.
2. Slowly slide in the new spine fan module.
3. Push the fan module as far as it will go, make sure the locking latches engage.



If the Fan LED continues to show red remove the fan module and check the pins on the connector inside of the spine to make sure that none of them are bent.

## 2.10.5 Management Module



When hot-swapping any of the units, it is necessary to wait 1 minute after removing the defective part before inserting the new part. This is necessary so that the management module will start a new cycle checking through the leafs and spines for the FW versions.

### Extracting a Management Module

Management modules are located on the leaf side, above the leafs. There are two places to install the management modules.



Only one management module is required to run the switch system.

Each management module has a pair of ejectors that lock the board in place and serve as a lever for seating or extracting (see Figure 55).

1. Run the shut down command "no power enable <module>". For example to shut down management module 2 run the command below.

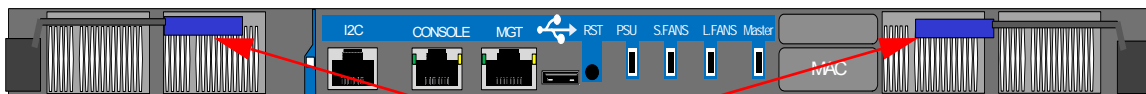
```
switch [master] (config) # no power enable MGMT2
```

2. Disconnect all cables connected to the management module.
3. Push outward on the ejector handles to unlock the ejectors from the chassis.
4. Open the ejectors until they are 45 degrees from the module.
5. Pull out the module half-way through the guiding rails using the ejector handle.
6. Lock the ejector handle.
7. Hold the body of the board on both sides and remove it from the chassis.



The board is short, therefore do not let go of it while sliding it out.

**Figure 55: Management Module**



### 2.10.5.1 Inserting a Management Module

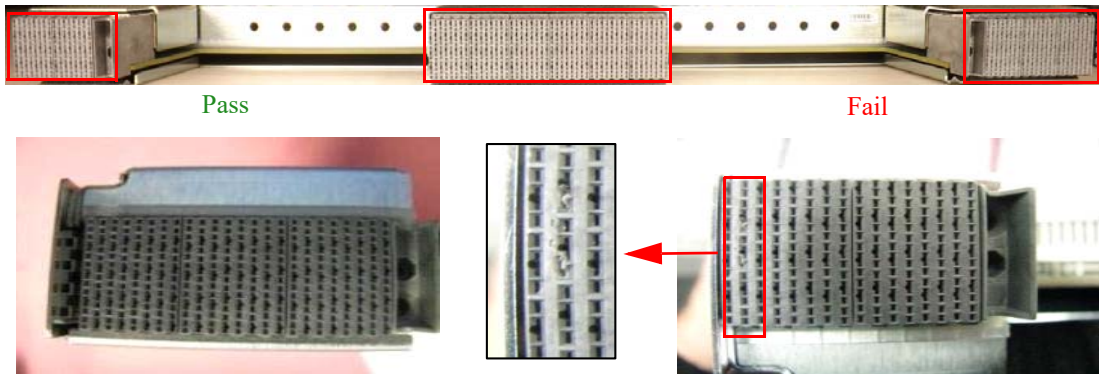


When hot-swapping any of the units, it is necessary to wait 1 minute after removing the defective part before inserting the new part. This is necessary so that the management module will start a new cycle checking through the leaves and spines for the FW versions.

To insert a management board:

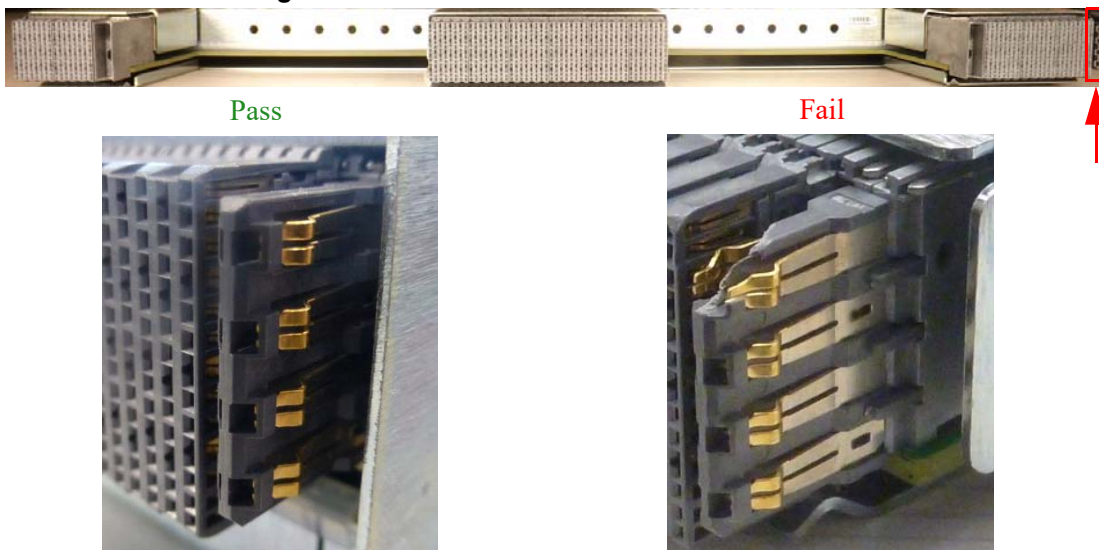
1. Check for foreign objects in or mechanical damage to the chassis management slots.
2. Check management mechanics for any noticeable damage.
3. Check back signal connectors' integrity. Look for any broken signal dividers or any deviations from the pass criterion shown in Figure 56.

**Figure 56: Intact vs Defected Signal Connectors**



4. Check power connector's integrity. Look for any damage on the power connector casing or blades damage, or any deviations from the pass criterion shown in Figure 57.

**Figure 57: Intact vs Defected Power Pin Holders**



5. Start with the ejector handles fully open; that is, at 45 degrees to the front panel of the management.
6. Holding the management by its sides, carefully set the management board into the chassis.
7. Using only the management ejector handles, slowly slide the board into the chassis until the hooks reach the vertical bar.



Do not apply excessive force to slide in the management board. If you feel resistance, remove the management and double check both the chassis and management for any damage.

8. Catch the hooks onto the vertical bar of the chassis and push the ejector handle shut.
9. Lock the ejector handles onto the board.



On switch systems with dual management systems, first connect the cable and configure the master management module CPU and only then configure the slave. By default the master CPU is the top management module. For further information on the master and slave roles, see the MLNX-OS® Software UM section “High Availability”.



All management modules in the chassis must go through an initial configuration procedure. See the Installation Guide for the initial configuration procedure.

### 2.10.6 Switch Shut-Down Procedures

To shut down the chassis run the following command twice (once for each MM):

```
Reload halt [noconfirm]
```



**The chassis cannot be restarted remotely!**

To restart the chassis you must physically go to the switch and unplug all of the power cords to the chassis and then replug in all of the power cords to the chassis.

The first time you run the command it shuts down the master management module and the second time shuts down the slave management module.

To shut down a leaf run the following command:

```
no power enable <module>
```

To shut down a spine run the following command:

```
no power enable <module>
```

To shut down a management module run the following command:

```
no power enable <module>
```

## 3 Interfaces

### 3.1 LED Status Indicators

The LEDs are placed on the chassis for the convenience of the IT manager. All chassis conditions and management options are available and controllable through the management software, either CLI or WebUI.

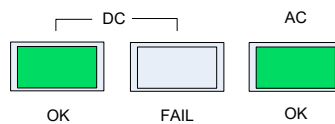


It is recommended that all of the chassis sub systems be maintained and managed through the management software.

#### 3.1.1 Power Supply Unit LEDs

Each Power Supply Unit has the following indicator LEDs.

**Figure 58: Power Supply Unit Status Indications**



AC – When lit this LED indicates input voltage between 100 and 240 Volts.

DC FAIL – When lit this LED indicates a fault in the power supply.

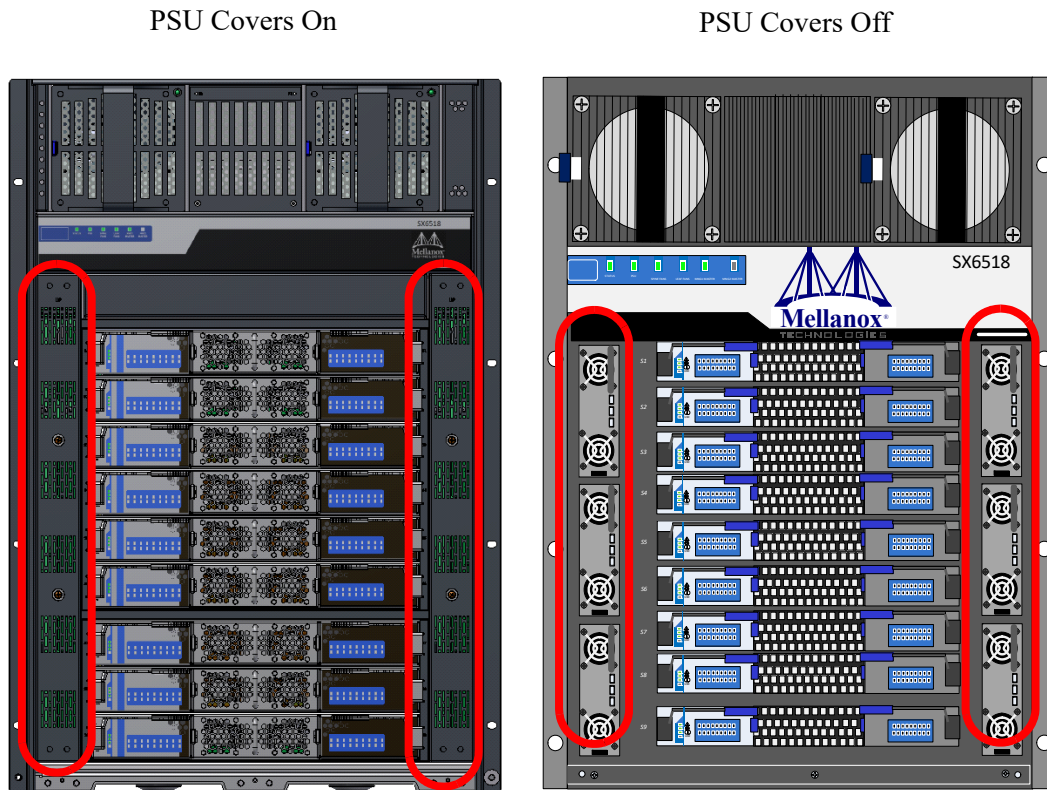
DC OK – When lit this LED indicates that the output from the power supply is +48 VDC.



The PSUs are on the spine side of the chassis behind two cover panels. The plugs for these PSUs are on the leaf side of the chassis.

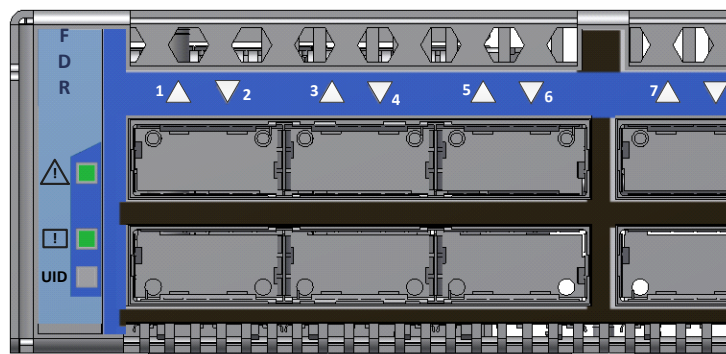


**Figure 59: PSU Cover On and Off**



### 3.1.2 Leaf Board LED Indicators

**Figure 60: Leaf Board Led Indicators**



#### 3.1.2.1 Status LED

Each leaf board has a Status LED on the far left of the leaf. Table 4 shows the leaf status according to the LED condition.



The Leaf Status indicator LED  has the following LED assignment:

**Table 4 - Leaf Status LED**

LED Condition	LED Description
Off	No power to the Leaf
Solid Green	Leaf is up and running
Flashing Green	Leaf is powering up
Solid Orange	Non fatal error – this leaf needs troubleshooting, but does not require chassis shutdown
Solid Red	Fatal error

### 3.1.2.2 Bad Port LED

The Bad Port indicator is located on the left side of the leaf. The following Bad Port conditions are possible:

**Table 5 - Bad Port LED Configurations**

LED Configuration	Description
Off	OK – all ports are up and running.
Flashing Orange	Error – one or possibly more ports has just received a symbol error

This LED shows symbol errors. Possible causes for this are:



- bad cable
- bad connection
- bad connector

This LED lights up when one or more ports is receiving a symbol error. The LED immediately goes off until the next symbol error is received.

### 3.1.2.3 UID LED Switch Identifier

The UID LED is a debug feature that will become available to customers in the near future. For details please contact Mellanox Technologies support.

### 3.1.2.4 Leaf Board Port Connector LED Assignment

Above the ports are two LEDs one for the upper port  and one for the lower port . Each port has a single 2 color LED. Table 6 shows the link status according to the LED condition.

**Table 6 - Connector Physical and Logical Link Indications**

LED Condition	LED Description
Off	No power to the port

**Table 6 - Connector Physical and Logical Link Indications**

LED Condition	LED Description
Solid Green	Logical link up
Flashing Green	Data activity – flashing speed is proportional to data transfer speed
Solid Orange	Physical link up
Flashing Orange	A problem with the physical link

The LED indicator, corresponding to each data port, will light orange when the physical connection is established (that is, when the unit is powered on and a cable is plugged into the port with the other end of the connector plugged into a functioning port). When a logical connection is made the LED will change to green. When data is being transferred the light will blink green.



The switch does not provide a visual means to indicate the port speed configuration (SDR, DDR, QDR, or FDR) and/or the link width (1X or 4X). The speed and link width configurations can be retrieved using management software.

### 3.1.3 Spine Board LED Indicators

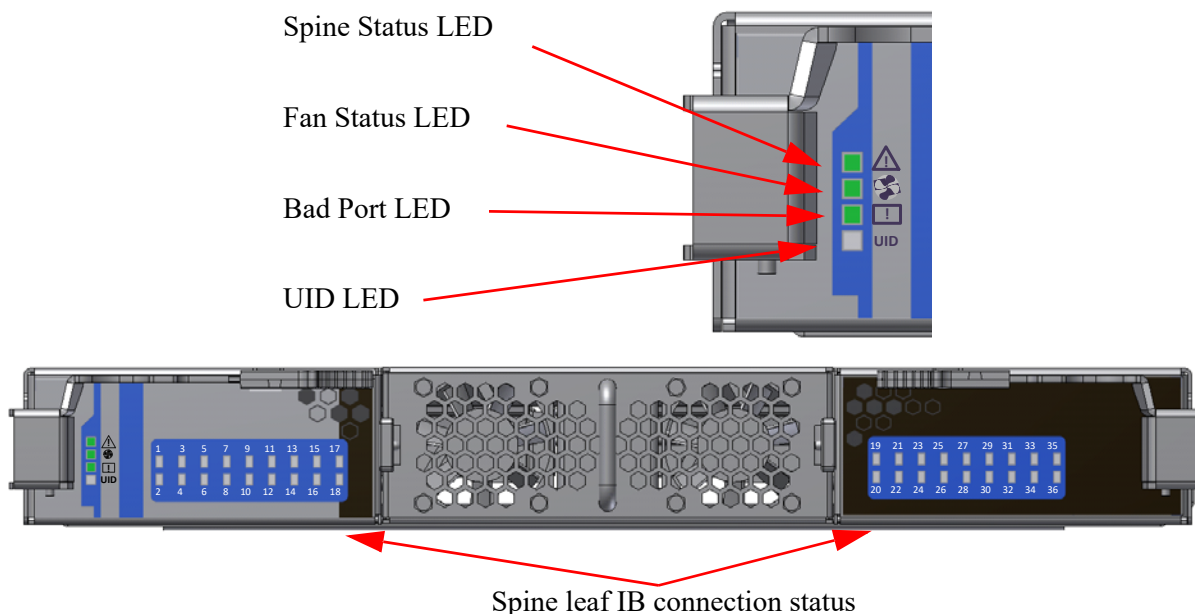
Each leaf board is connected by links to each spine module. Each spine has the following LEDs.

- One status LED for the spine health
- One status LED for the spine fan modules
- 36 status LEDs showing the existence of leaf to spine connections
- One Bad Port Led showing symbol errors in the data stream
- One UID LED that can be lit to identify an individual spine

The 36 LEDs on each spine are divided by the number of leafs and the result (N) is the number of connections from each leaf that are connected to the spine. 9 spines must be installed and working to ensure that full BW exists between nodes. The maximum number of connections from each leaf is 2. If the (number of leafs) x (the maximum number of connections per leaf) is less than 36 then some of the leaf to spine connection LEDs may be OFF.

The status LEDs for the spine and their descriptions are shown in Table 7. The LEDs indicate as follows.

**Figure 61: Spine Status LEDs**



### 3.1.3.1 Status LED

Table 7 shows the spine status according to the LED condition.

**Table 7 - Spine Status LED**

LED Condition	LED Description
Off	No power to the spine
Solid Green	Spine is up and running
Flashing Green	Spine is powering up
Solid Orange	Non fatal error – this spine needs troubleshooting, but does not require chassis shutdown
Solid Red	Fatal error

### 3.1.3.2 Fan LED

The spine fan indicator LED has the following LED assignment:

**Table 8 - Spine Fan Status LED**

LED Color	LED Description
Solid Green	Spine Fan is OK
Flashing Green	Spine Fan needs replacing
Solid Yellow	One or more of the fans in this spine is not working Each spine has two fans in the fan module

### 3.1.3.3 Spine to Leaf IB Connection Status LEDs

The leaf connection status on each spine displays the condition of the connection between the spine and each leaf. There is a minimum of one LED per leaf per spine and a maximum of 2 LEDs per leaf. These LEDs indicate a valid connection between a leaf and a spine.

Table 9 shows the leaf to spine status according to the LED condition.

**Table 9 - Spine to Leaf IB Link Status**

LED Condition	LED Description
Off	Link is down
Solid Green	Logical connection
Flashing Green	Data activity
Solid Orange	Physical connection

### 3.1.3.4 Bad Port LED

The Bad Port indicator is located on the left side of the spine. The following Bad Port conditions are possible:

**Table 10 - Bad Port LED Configurations**

LED Condition	Description
Off	OK – No ports have received symbol errors recently
Flashing Orange	Error – One or possibly more ports has just received a symbol error.

This LED shows symbol errors. Possible causes for this are:

- bad cable
- bad connection
- bad connector

This LED lights up when one or more ports is receiving a symbol error. The LED immediately goes off until the next symbol error is received.

### 3.1.3.5 UID LED Switch Identifier

The UID LED is a debug feature that will become available to customers in the near future. For details please contact Mellanox Technologies support.

## 3.1.4 Spine Side Panel Display LED Indicators

The spine side panel display has LEDs that show the chassis condition.

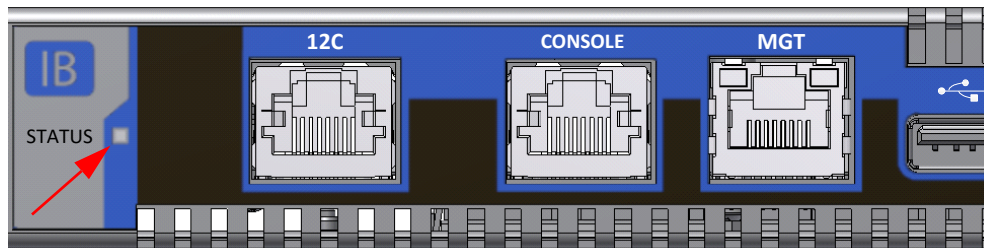
**Figure 62: Spine Side Panel Display Status Indications**

**Table 11 - Spine Side LED Display for Normal Operation**

LED Condition	Description	Normal State
STATUS	Off – No Power Green – System is up and running Yellow – System warning. Attention needed (such as overheating) Red – System not operational (Diagnostics fail, CPU hang, HW fail, Overheat-critical) Blinking green – System booting / Restore factory defaults in progress	Green
PSU STATUS	Off – No power Green – Normal operational Red – PS fault detected. User should check individual power supplies for fault indications.	Green
SPINE FANS STATUS	Off – No power to fan Green – Nominal operational Red – One or more of the spine fans is bad. User should check individual spine fan LEDs for fault indications.	Green
LEAF FANS STATUS	Off – No power to fan Green – Nominal operational Red – One or more of the leaf fans is bad. User should check individual leaf fan LEDs for fault indications.	Green
MNG1 MASTER STATUS	Off – <ul style="list-style-type: none"> <li>- no power</li> <li>- this management module is not installed</li> <li>- this management module is not the master</li> </ul> Green – Management module is operating as a master	Green
MNG2 MASTER STATUS	Off – <ul style="list-style-type: none"> <li>- no power</li> <li>- this management module is not installed</li> <li>- this management module is not the master</li> </ul> Green – Management module is operating as a master	Off

### 3.1.5 Management Module LED Indicators

**Figure 63: Management Module Status Indications**

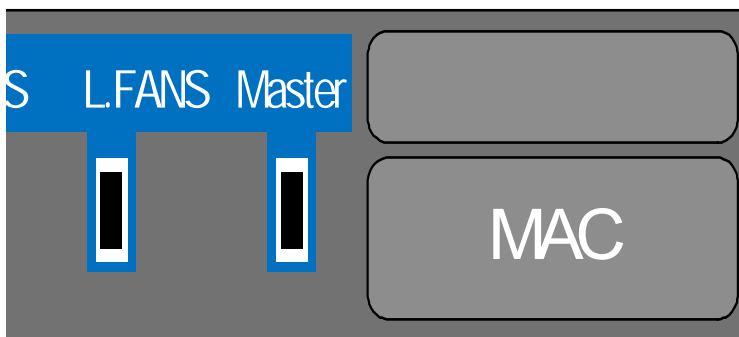


The management module LEDs display the switch system operating conditions.

**Table 12 - Management LED Display for Normal Operation**

LED Condition	Description	Normal State
<b>STATUS</b> This LED shows the status of the chassis.	Off – No Power Green – System is up and running Yellow – System warning. Attention needed (such as overheating) Red – System not operational (Diagnostics fail, CPU hang, HW fail, Overheat-critical) Blinking green – System booting / Restore factory defaults in progress	Green
<b>PSU STATUS</b>	Off – No power Green – Normal operational Red – PS fault detected. User should check individual power supplies for fault indications.	Green
<b>SPINE FANS STATUS</b>	Off – No power to fan Green – Nominal operational Red – One or more of the spine fans is bad. User should check individual spine fan LEDs for fault indications.	Green
<b>LEAF FANS STATUS</b>	Off – No power to fan Green – Nominal operational Red – One or more of the leaf fans is bad. User should check individual leaf fan LEDs for fault indications.	Green
<b>MASTER</b>	Off – <ul style="list-style-type: none"> <li>- no power</li> <li>- this management module is not the master</li> </ul> Green – Management module is operating as a master	Green if master Off if slave

**Figure 64: Management Module LEDs**



### 3.1.5.1 Management Module PSU LED Indicator

The management module PSU indicator should be green.

**Table 13 - Management Module PSU LED Configurations**

LED Condition	Description
Green	OK – All PSUs are working at correct input and output voltages.
Red	Error – One or more of the PSUs for the chassis is bad. Check each PSU for a red LED.

### 3.1.5.2 Management Module S. FANS LED Indicator

The management module S. FANS indicator should be green.

**Table 14 - Management Module S.Fan LED Configurations**

LED Condition	Description
Green	OK – All Spine fans are working at configured speed.
Red	Error – One or more of the spine fans within a spine fan module is bad. Check the spines for a flashing green fan LED.

### 3.1.5.3 Management Module L. FANS LED Indicator

The management module L. FANS indicator should be green.

**Table 15 - Management Module L.Fan LED Configurations**

LED Condition	Description
Green	OK – All Chassis Leaf fans are working at configured speed.
Red	Error – One or more of the leaf fans for the chassis is bad. Check each chassis fan for a red LED.

### 3.1.5.4 Management Module MASTER LED Indicator

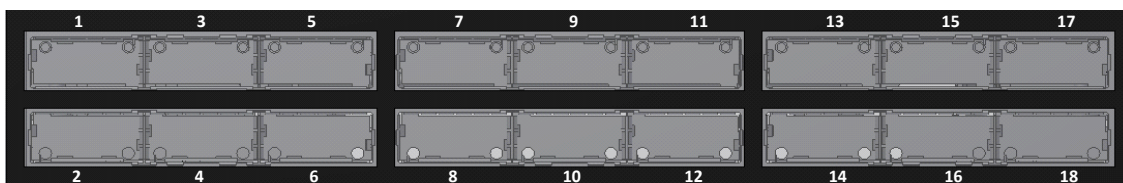
**Table 16 - Management Module MASTER LED Configurations**

LED Condition	Description
Green	This management module is the master.
Off	This management module is the slave.

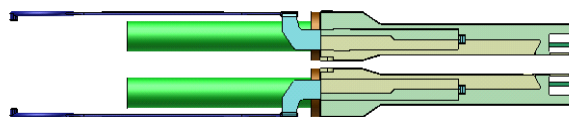
### 3.1.6 Port Connector Interfaces

The connector side of the switch has 18 leaf boards and each leaf board has 18 QSFP ports. The ports on each leaf board are placed in two rows, 9 ports to a row. The ports are labelled as shown in Figure 65. The bottom row ports are flipped from the top row. See Figure 66.

**Figure 65: Port Numbering**



**Figure 66: Top and Bottom Ports**



## 3.2 Air Flow

These switches come with the air flow pattern of air entering through the spine side and exiting through the connector side.

## 3.3 QSFP Cable Power Budget Classification

All SX6518 QSFP switches are designed for active cables with a max power per module of 2.0W. This is power level 2 according to the QSFP Public Specification.

## 3.4 Management Module Interfaces

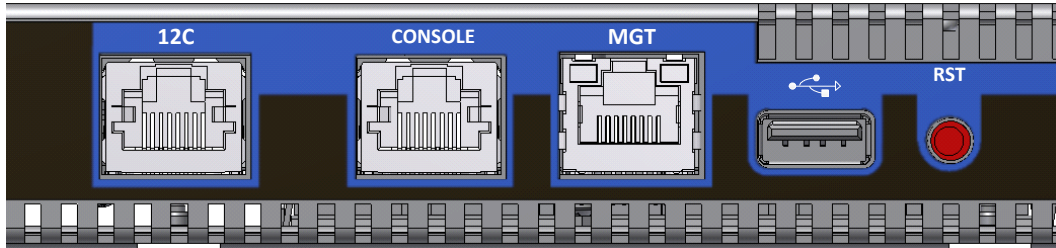
The switch system requires at least one management module. The management module has five interfaces to connect to the SX6518. They are:

- 1 I2C port
- 1 CONSOLE port – this is an RS232 connector for connecting to a host machine
- 1 MGT – this is an Ethernet connector
- 1 USB port



- 1 RST – reset button

**Figure 67: Management Module Interfaces**



### 3.4.1 I2C



This interface is for Debug and Troubleshooting only. This interface is for FAEs only.

### 3.4.2 CONSOLE

The CONSOLE port is used during the installation process to configure the chassis for remote management. Connect this port to a local host using the harness supplied with the chassis. See the Installation Guide for the initial configuration procedure.

### 3.4.3 MGT– Management

The MGT port is an Ethernet port for remote management. Any remote terminal connected to the Ethernet port can then be used to manage the fabric and chassis.



Each Ethernet connector gets connected to Ethernet switches. These switches must be configured to 100M/1G auto-negotiation.



Initial configuration must be done on all of the management modules. The first management module you configure will be the master.

### 3.4.4 USB

The USB port can be used to upload new SW using any storage device that has a USB connector. This interface is USB 2.0.

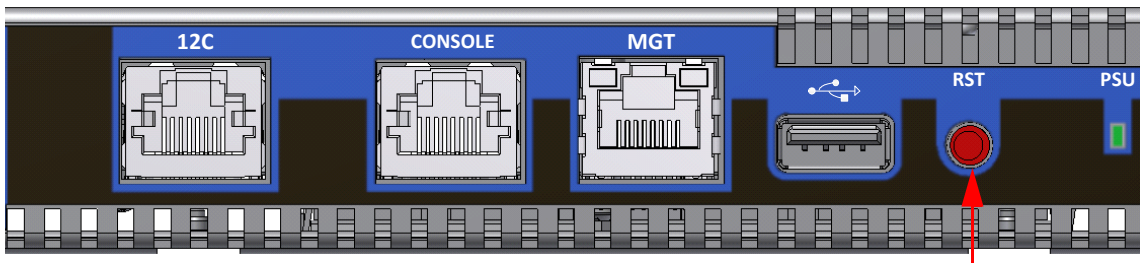
### 3.4.5 Reset – RST

The Reset button resets the chassis management module when the button is pushed. When the button is held down for 15 seconds the management module is reset and the password deleted.



DO NOT use a sharp pointed object such as needle or push pin for pressing the Reset button. Sharp objects can cause damage, use a flat object such as a paper clip.

**Figure 68: Reset Button**



This button resets the CPU of the management module. A quick push of this button performs this reset. When the reset button is pushed on the master management module this management module is reset becoming the slave and the other management module becomes the master. If there is only one management module in the chassis all of the leafs and ports are reset by bringing them down and powering them up when the reset button is pushed. When the button is held down for 15 seconds the management module is reset and the password is deleted. You will then be able to enter without a password and make a new password for the user “admin”.

## 3.5 AC power interface

The system AC interface is based on IEC60320 C13/C14 power couplers. The C13 based PDUs must be used to successfully connect the system to the power source. Insure the PDU used has the required number of C13 sockets and the number of PDUs reflect the desired power redundancy level, refer to [“Power Supply Redundancy” on page 18](#). for more details.

## 4 Chassis Power Up



Before starting any procedure on the SX6518 system put an ESD prevention wrist strap on your wrist and connect to the SX6518 chassis.

With N+1 PSU redundancy the chassis must be started with a full complement of possible PSUs, thereafter it can run on one less than the total number of PSUs. This final PSU is redundant and allows for hot swapping a PSU should one fail. Connecting the PSUs to different AC lines provides AC failover protection.

The system should continue to run and allow a hot swap of a defective PSU. Should there not be enough power to keep all of the leafs running, MLNX-OS® may power down some leafs. If this happens it will be necessary to reboot the chassis once the defective PSU has been replaced.

With 1670W optional PSU supplies the chassis can run on as little as 1/2 of the full complement of PSUs. N+N allows the chassis to run on 3 PSUs supplied from one power grid while 3 are connected to a second power grid.

1. Check all FRUs for proper insertion and seating before connecting the AC power cords.
  - Boards
  - Power supplies
  - Leaf fan modules
  - Spine fan modules
2. Insert all leafs that you plan to use, in the chassis. Start at the bottom of the chassis and work your way up.
3. Insert the first two spines in the top two slots.
4. Insert the rest of the spines from the bottom of the chassis up to slot #3.
5. Insert thermal blanks in unused leaf slots to maintain balanced air flow.
6. Tighten all leaf and spine mounting screws.
7. Connect the power cords to the PSUs.
8. Connect the power cords to grounded electrical outlets.



With N+1 PSU redundancy do not power up the chassis with less than all PSUs installed.

## 4.1 Power Supply and Spine Board Indicator Status at Power ON

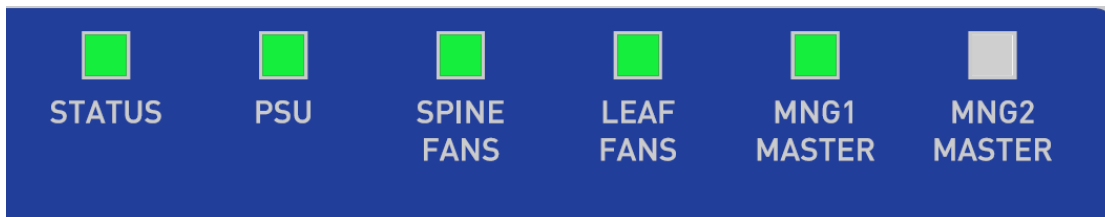


It can take up to 5 minutes to boot up the system. Turn off the system if any LEDs remain red for more than 5 minutes.

As the power is turned on, you should observe the following conditions for normal operation:

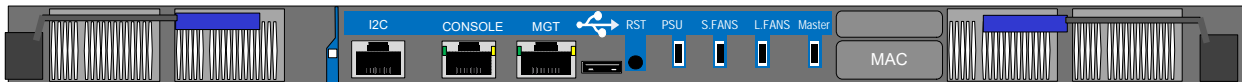
1. Power Supply Unit(s) AC OK and DC OK indicators are ON and FAIL indicators are OFF.
2. There is a *green* Status LED per spine board, per leaf board, and per management module that indicates power supplies are good.
3. Spine Board indicators will display status of internal links to the installed leaf boards. All PHY links to existing leaf Boards should be ON.
4. Check the Spine LEDs and make sure they coincide with Figure 69.

**Figure 69: Spine Side Panel Display Status Indications**



5. Check the Management Module LEDs and make sure they coincide with Figure 70.

**Figure 70: Management Module Status Indications for Normal Operation**



## 5 Switch Management Tools

This chapter describes the management module and tools available for Out-of-Band management of the switch system via MLNX-OS®.



There are 2 Ethernet ports (1 for each management module) that get connected to Ethernet switches. These switches must be configured to 10/100M auto-negotiation.

The SX6518 switch comes standard with a management software module for chassis management called Mellanox Operating System (MLNX-OS). MLNX-OS is installed on all SwitchX® based managed switch systems management modules. MLNX-OS includes a CLI, WebUI, SNMP, and chassis management features for software and IB management software (OpenSM).

You can get more information via the Mellanox MLNX-OS® SwitchX® Software WebUI User's Manual or the Mellanox MLNX-OS® SwitchX® Software User Manual.

The managed switch system includes the following software components:

- Embedded Subnet Manager (SM)
- Chassis manager and system BIST
- SNMP agent, 3rd party tool integration
- GUI
- Remote logging
- SSH/telnet
- Secured access in-band and out-band
- IPv4/IPv6 network stack

The chassis manager will give the user access to:

- Switch temperatures
- Power supply voltages
- Fan unit information
- Power unit information
- Flash memory
- Monitoring of:
  - AC power to the PSUs
  - DC power out from the PSUs
  - chassis failures
- querying for:
  - switch serial numbers
  - revisions

- software version
- SwitchX® FW version
- switch temperatures

The manager also has the ability to burn new firmware and upgrade software on the switch.

## 5.1 InfiniBand Subnet Manager

The InfiniBand Subnet Manager (SM) is a centralized entity running in the switch. It discovers and configures all the InfiniBand fabric devices to enable traffic flow between those devices. The SM applies network traffic related configurations such as QoS, routing, partitioning to the fabric devices.

You can view and configure the Subnet Parameters (SM) via the CLI/WebUI.

Each InfiniBand subnet needs one subnet manager to discover, activate and manage the subnet. An InfiniBand® network requires a Subnet Manager to be running in either the Infiniband switch itself (switch based) or on one of the nodes which is connected to the Infiniband fabric (host based).

## 5.2 Fabric Inspector (Diagnostics)

Fabric Inspector is a plug & play software for free within MLNX-OS displaying and filtering all identified systems and nodes within the fabric.

Fabric Inspector includes a complete set of tools for fabric wide diagnostics to check node-node and node-switch connectivity and to verify routes within the fabric.

Advanced filtering allows creating filtering rules on a system wide basis, between nodes or port connections based on traffic patterns and user assigned system names (GUIDs).

## 5.3 Accessing the CPU via the Ethernet Connector

Once the initial configuration is completed the management tools can be accessed through:

- SSH
- Telnet
- WEB
- SNMP
- XML

## 5.4 Upgrading and Downgrading Software

The new software and firmware images are available to the user from the MyMellanox website. Copy an image to a known location on a Remote server within your LAN.

Use the CLI or the WebUI to perform the software upgrade/downgrade. For further information please refer to the MLNX-OS user manual.

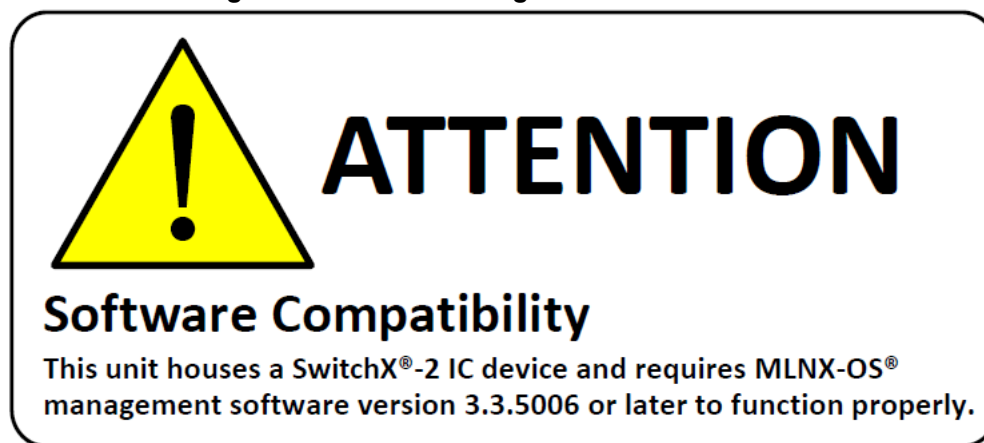


If MLNX-OS is updated and the FW image in the leafs and spines of the chassis is an earlier version than the minimum that the new version of the software can work with, then the chassis management system may require up to ~45 minutes to update all of the FW images in all of the leafs and spines.

#### IMPORTANT NOTE

If in possession of an FDR director switch with the notice presented in [Figure 71](#), the lowest MLNX-OS version you can downgrade to is 3.3.5006; otherwise, the switch system will malfunction.

*Figure 71: SX65xx Downgrade Attention Sticker*



## 6 Troubleshooting

### 6.1 Power Supply Unit



If the Power supplies cannot supply enough power, the management module may shut down the some leafs.

As each PSU is plugged in, make sure that the green power LEDs on the PSU comes on.

**Issue 1. If the AC power LED is off:**

1. Check that the power cable is the correct power cable for your country.
2. Check that the power cable is plugged into a working outlet.
3. Check that the power cable has a voltage within the range of 100 - 240 volts AC.
4. Remove and reinstall the power cable.
5. Check the circuit breakers to be sure that the breaker has not tripped.
6. Check that the power cable is good. Replace the power cable.
7. If the AC power LED is green but the OK power LED is off or the FAIL LED is on – Replace the PSU.

### 6.2 Leaf Board

**Issue 2. The power LED for the Leaf board is off:**

1. Make sure that all of the PSUs are showing DC OK.
2. Uninstall and reinstall the Leaf board.
3. When the Yellow LED is on, this indicates a fault in the board, uninstall and reinstall the Leaf board.
4. If uninstalling and reinstalling the Leaf board does not work, burn the latest FW on the Leaf board and uninstall and reinstall the Leaf board.
5. Replace the Leaf board with a new one.



Should any of the boards shut down due to over temperature, wait 5 minutes and then follow the procedure starting with Step 2

**Issue 3. The Physical link LED for the InfiniBand connector does not come on:**

1. Check that both ends of the cable are connected.
2. Check that the locks on the ends are secured.
3. Make sure that the latest FW version is installed on both the HCA card and the switch.
4. If media adapters are used check that the all connections are good, tight, and secure.
5. Replace the cable.

**Issue 4. The Activity indication does not come on:**



Check that the Subnet Manager has been started.

## 6.3 Management Module

### Issue 1. Yellow Status LED for the Chassis on the Management Module is Lit

1. Check the MLNX-OS management for confirmation and possible explanation of the alert.
2. Reset the master management module by pushing the rest button. If you have two management modules installed this will convert the master management module to the slave and convert the slave to the master.



If there is only one management module in the chassis all of the leafs and ports are reset by bringing them down and powering them up when the management module is removed.

3. Make sure the S.Fans and L.Fans LEDs are green.
4. Make sure that the spine and the leafs both have the same version of FW.
5. Reburn the FW and remove and reinstall the management module.
6. If you are running the chassis with only one management module, remove and reinstall the management module. Make sure the mating connectors of the unit are free of any dirt and/or obstacles. See Section 2.10.5 on page 68.
7. If you are running the chassis with only one management module, replace the management module.

### Issue 2. Yellow LED for the Leaf Fan on the Management Module is Lit

1. Check the MLNX-OS management for confirmation and possible explanation of the alert.
2. Make sure that there is nothing blocking the front or rear of the chassis and that the fan modules and ventilation holes are not blocked (especially dust over the holes).
3. If you find dust blocking the holes it is recommended to clean the fan unit and remove the dust from the front and rear panels of the switch using a vacuum cleaner.
4. Determine which fan module is problematic by checking the status LED on each fan module.
5. Remove and reinstall the problematic fan unit. Make sure the mating connector of the new unit is free of any dirt and/or obstacles. See Section 2.10.4 on page 65.
6. Replace the Leaf fan module.



There are two non-interchangeable types of leaf fan modules. If the new leaf fan does not go into the chassis confirm that it is the correct fan module.



Replace defective leaf fan modules as soon as they are identified.



Should any of the boards shut down due to over temperature, follow the procedure starting in Step 2

**Issue 3.** Yellow LED for the Spine Fan on the Management Module is Lit

1. Check the MLNX-OS management for confirmation and possible explanation of the alert.
2. Determine which spine has a defective fan by checking the Fan LEDs on all of the spines.
3. Make sure that there is nothing blocking the front or rear of the chassis and that the fan modules and ventilation holes are not blocked (especially dust over the holes).
4. If you find dust blocking the holes it is recommended to clean the fan unit and remove the dust from the front and rear panels of the switch using a vacuum cleaner.
5. Remove and reinstall the fan unit of the spine. Make sure the mating connector of the new unit is free of any dirt and/or obstacles. See Section 2.10.4 on page 65.
6. Replace the spine fan module.



Replace defective spine fan modules as soon as they are identified.

## 6.4 Spine Board

**Issue 1.** The yellow LED on the Spine board is lit:

1. Check the MLNX-OS management for confirmation and possible explanation of the alert.
2. Make sure that there is nothing blocking the front or rear of the chassis and that the fan modules and ventilation holes are not blocked (especially dust over the holes).
3. If you find dust blocking the holes it is recommended to clean the fan unit and remove the dust from the front and rear panels of the switch using a vacuum cleaner.
4. Remove and reinstall the spine board. Make sure the mating connectors of the unit is free of any dirt and/or obstacles. See Section 2.10.3 on page 60.
5. Make sure that the spine and the Leafs both have the same version of FW.
6. Reburn the FW and remove and reinstall the spine.
7. Replace the spine board.

## 6.5 MLNX-OS® Software

**Issue 1.** The last software update did not succeed:

1. Connect the RS232 connector (CONSOLE) to a laptop.
2. Push the reset button on the switch or management module.
3. You will have ~ 5 seconds to stop the U-Boot by pressing Control-B.
4. Choose the image to upload. Only use image 1 or image 2.

```

U-Boot 2009.01-mlnx1.4 (May 12 2010 - 14:08:15)

CPU:   AMCC PowerPC 460EX Rev. A at 1000 MHz (PLB=200,
OPB=100, EBC=100 MHz)
Security/Kasumi support
Bootstrap Option H - Boot ROM Location I2C (Addr 0x52)
      Internal PCI arbiter disabled
      32 kB I-Cache 32 kB D-Cache
Board: Mellanox PPC460EX Board
FDEF:  No
I2C:   ready
DRAM:  2 GB (ECC enabled, 400 MHz, CL3)
FLASH: 16 MB
NAND:  1024 MiB
PCI:   Bus Dev VenId DevId Class Int
PCIE0: link is not up.
PCIE1: successfully set as root-complex
      01 00 15b3 bd34 0c06 00
Net:   ppc_4xx_eth0, ppc_4xx_eth1
Hit Ctrl+B to stop autoboot:  0

Mellanox FabricIT

Boot Menu:
  1. EFM_PPC_M460EX EFM_1.1.1000 2010-06-24 16:32:03 ppc
  2. EFM_PPC_M460EX EFM_1.1.1200 2010-06-25 18 :00:03 ppc
  3. U-Boot prompt
Choice:
    
```

5. Select the image to boot.



For more detailed instructions concerning MLNX-OS® software see the Mellanox MLNX-OS® SwitchX® Software WebUI User's Manual or the Mellanox MLNX-OS® SwitchX® Software User Manual.

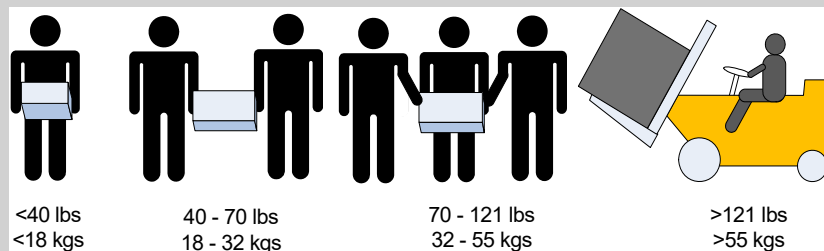
## 7 Disassembly and Disposal

### 7.1 Disassembling the Chassis

1. Power down the chassis.
2. Remove all power cables.
3. Remove all connector cables.
4. Disconnect the ground lug from the ground post.
5. Loosen all locking screws for the leafs, spines, and management modules in the chassis.
6. Remove all leafs.
7. Remove all spines.
8. Remove all management modules.



Use enough people to safely lift this product.



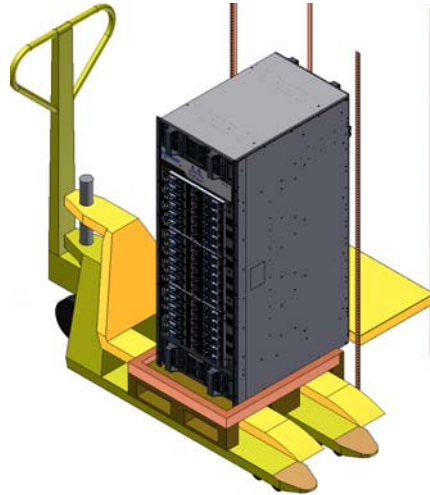
This product and all of its parts are NOT to be disposed of with household waste. This product contains printed circuit boards cables and batteries. According to the WEEE Directive 2002/96/EC, all waste electrical and electronic equipment (EEE) should be collected separately and disposed of according to the directive.

9. Go to the Mellanox website for detailed instructions for disassembly of the FRUs and chassis according to the WEEE Directive.
10. Dispose of these pieces in a legal and environmentally friendly way.

#### 7.1.1 Removing the Chassis

1. Remove the screws connecting the upper brackets to the rack.
2. Remove the screws holding the chassis to the rack. These screws are located in the faceplate on the spine side of the chassis.
3. Remove the upper brackets from the chassis.
4. Remove the lock-down bars.

**Figure 72: Mechanical Lifting Device**

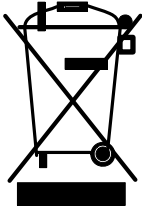


5. Put the container base (saved from the installation) on the fork lift.
6. Raise the container base to 1 cm below the level of the shelf.
7. Move the chassis away from the rack and onto the container base.
8. Put wedges around the chassis to prevent the chassis from rolling off of the container base.
9. Move the chassis away from the rack.
10. Dispose of the Chassis in a legal and environmental way.
11. Go to the Mellanox website for detailed instructions for disassembly of the chassis according to the WEEE Directive.

### **7.1.2 Removing the Bottom Shelf**

1. Remove all of the bolts that are holding the shelf to the rack.
2. Remove the filler panels.
3. Remove the shelf.
4. Remove all of the caged nuts.

## 7.2 Disposal



According to the WEEE Directive 2002/96/EC, all waste electrical and electronic equipment (EEE) should be collected separately and not disposed of with regular household waste.

Dispose of this product and all of its parts in a responsible and environmentally friendly way.

Go to the Mellanox website for detailed instructions for disassembly according to the WEEE Directive.

## Appendix A: Specification Data

**Table 17 - Switch Specification SX6518**

Physical	
Size	28" x 19" x 27" inches 711mm x 482.6mm x 685mm The shelf adds 66.7mm to the height
Mounting	19" Rack mount
# of Spines	9
# of Leafs	18
Weight	90kg (199 lbs) empty configuration 112 kg (247 lbs) shipped configuration 212.36kg (468 lbs) full configuration
Center of Gravity*	CoGh: 311.80mm (from bottom of chassis) CoGw: 222.00mm (from left side surface) CoGd: 328.14mm (from port-end surface) *Measured from the bottom left corner as one faces the switch ports
Max. Air Flow Through Leafs	17.455M <sup>3</sup> /min (616.8 CFM)
Max. Air Flow Through Spines	3.427M <sup>3</sup> /min (121.1 CFM)
Total Max. Air Flow	20.882M <sup>3</sup> /min (737.9 CFM)
SerDes Speeds	10, 20, 40,Gb/s or 56,Gb/s per port
Connector Types	QSFP
Sound Level / Ports	76 db(A)
# of Ports	324
Power and Environmental	
Input Voltage	100 - 240 VAC 50-60Hz
Total Power Consumption FDR 10	Typical Passive: 3038W Active: 3777W (includes QSFP at 1.5W) Optical: 3876W (includes QSFP at 1.7W)
	Maximum Passive: 3522W Active: 4359W (includes QSFP at 1.7W) Optical: 4507W (includes QSFP at 2.0W)

**Table 17 - Switch Specification SX6518**

Physical	
<b>FDR 10 Max Heat Output</b>	15,378 BTUs/hr
<b>Total Power Consumption FDR 14</b>	Typical      Passive: 3715W Active: 4455W (includes QSFP at 1.5W) Optical: 4554W (includes QSFP at 1.7W)
	Maximum      Passive: 3909W Active: 4746W (includes QSFP at 1.7W) Optical: 4896W (includes QSFP at 2.0W)
<b>Max Heat Output</b>	16,706 BTUs/hr
<b>Temperature</b>	Operating: 0° to 45° Celsius Non-operating: -40° to 70° Celsius
<b>Humidity</b>	Operating: 10% - 85% non-condensing
Protocol Support	
<b>Speed protocol</b>	InfiniBand: Auto-negotiation of 56Gb/s, 40Gb/s, 20Gb/s, 10Gb/s
<b>Management</b>	MLNX-OS and baseboard, performance, and device management agents for full InfiniBand in-band management.
<b>Data Rate</b>	56Gb/s per port
<b>QoS</b>	8 InfiniBand virtual lanes for all ports
Regulatory Compliance	
<b>Safety</b>	CB CE cTUVus CU For more compliance information please refer to the following page on the Mellanox webpage: <a href="http://www.mellanox.com/page/switch_certification_matrix">http://www.mellanox.com/page/switch_certification_matrix</a> .
<b>EMC (Emissions)</b>	CE FCC ICES RCM VCCI For more compliance information please refer to the following page on the Mellanox webpage: <a href="http://www.mellanox.com/page/switch_certification_matrix">http://www.mellanox.com/page/switch_certification_matrix</a> .
<b>Environmental</b>	EU: IEC 60068-2-64: Random Vibration EU: IEC 60068-2-29: Shocks, Type I / II EU: IEC 60068-2-32: Fall Test



**Table 17 - Switch Specification SX6518**

Physical	
Acoustic	76.4 DbA ISO 7779 ETS 300 753
Shock and Vibration	ETSI EN 300 019-2-2: 1999-09
Scalability and Performance	
Switching Performance/ Capacity	Addressing: 48K unicast addresses max. per subnet and 15.5K multicast addresses per subnet
	Leafs: Up to 18 leafs; 18-ports each
	Spines: 9 spine boards. All spines are needed for non-blocking configuration.
	Management modules: 2 available, 1 required for operation
	Management CPU: PowerPC 460EX
	Power supplies: 6 power supplies standard
	Leaf fans: 4 Spine fans: 9

## A.1 EMI Certification

EMI certification on the fully populated chassis was performed with the chassis installed in a closed two-door rack using the chassis installation kit supplied by Mellanox Technologies.

## A.2 Approved Cables

For a list of all approved cables see:

[http://www.mellanox.com/related-docs/user\\_manuals/Mellanox\\_approved\\_cables.pdf](http://www.mellanox.com/related-docs/user_manuals/Mellanox_approved_cables.pdf)

## A.3 EMC Certifications

The list of approved certifications per chassis in different regions of the world is located on the Mellanox Website at:

[http://www.mellanox.com/related-docs/user\\_manuals/Regulatory\\_and\\_Compliance\\_Guide.pdf](http://www.mellanox.com/related-docs/user_manuals/Regulatory_and_Compliance_Guide.pdf)

EMC Statements are also in the Regulatory and Compliance Guide.

## Appendix B: Thermal Threshold Definitions

There are three thermal threshold definitions for the SwitchX® switch device which impact the overall switch system operation state: Warning, Critical and Emergency.

### 1. Warning – 100°C

On managed systems only: When the SwitchX® device crosses the 100°C threshold, a Warning Threshold message will be issued by the MLNX-OS management SW, indicating to system administration that the switch has crossed the Warning threshold.

Note that this temperature threshold does not require nor lead to any action by hardware (such as switch shutdown).

### 2. Critical – 120°C

When the SwitchX® device crosses this temperature, the firmware will automatically shut down the device.

### 3. Emergency – 130°C

In case the firmware fails to shut down the SwitchX® device upon crossing the Critical threshold, the SwitchX® device will auto-shutdown upon crossing the Emergency (130°C) threshold.

## Appendix C: Calculating the Weight of a Customized Chassis

The weight of a customized chassis can be calculated for any possible customization as follows.

Take the weight of a chassis with the following FRUs installed.

- All fans modules
- All power supplies

The weight of the SX6518 chassis configured above is 112kg.

To this add the weight of installed FRUs.

- Spines
- Leafs
- Leaf blanks
- Management modules

Fill in the Table 18 to calculate the weight of your system.

**Table 18 - Switch System Weight Calculation**

Number of FRUs	FRU Type	Weight of 1 FRU [kg]	Total Weight [kg]
	Chassis as shipped	34.6	
	# of Spines *	3.77 =	
	# of leafs *	2.76 =	
	# of leaf blanks *	0.764 =	
	# of management modules *	3.15 =	
	# of PSUs	1.97 =	
	Total	=	

This total is in kilograms. Multiply the total by 2.2 to get the total weight in pounds.

## Appendix D: Calculating the Power of a Chassis

To calculate the power consumption of a chassis add the power of the fans, spines, leafs, and management modules.

**Table 19 - Power Consumption of Chassis Parts**

Part	Typical (W)	Maximum (W)
IB FDR leaf with passive cables	109.5	111.4
IB FDR leaf with 18 active cables	150.6	157.9
IB FDR leaf with 18 optical cables	156.1	166.2
Spine FDR	128.6	135.2
IB FDR10 leaf with passive cables	84.4	97.1
IB FDR10 leaf with 18 active cables	125.5	143.6
IB FDR10 leaf with 18 optical cables	131.0	151.8
Spine FDR10	103.5	120.8
Chassis fans	551.8	635.5
Management module	17.6	25.9

Table 19 assumes the QSFP cable power consumption specified in Table 20. Please note that QSFP module power is related to the module itself and is not referenced to AC plane.

**Table 20 - QSFP Cable Power Consumption**

QSFP Cable Type	Typical (W)	Maximum (W)
Active	1.5	1.7
Optical	1.7	2.0

To calculate the total power consumption of the switch system at a certain configuration, fill out Table 21 in the following manner:

1. In the Power column fill in the desired typical or maximum values.  
Be careful not to mix FDR and FDR10 power numbers for the particular calculation.
2. In the Quantity column, fill in the desired configuration.  
Please note that the number of fans is not configurable and is always 1.
3. Get the total power per each FRU by multiplying values in adjusted columns in the same row.
4. Get the total switch system power consumption system power by summing up all multiplication products.

**Table 21 - Calculating Total Switch System Power Consumption**

Part	Quantity	Power	Quantity x Power
IB FDR or FDR10 leaf with passive cables			

**Table 21 - Calculating Total Switch System Power Consumption**

Part	Quantity	Power	Quantity x Power
IB FDR or FDR10 leaf with active cables			
IB FDR or FDR10 leaf with optical cables			
Spine FDR or FDR10			
Chassis fans	1		
Management module			
Total power			



N+N redundancy ONLY works with a supply voltage of 220V.

## Appendix E: QSFP Interface

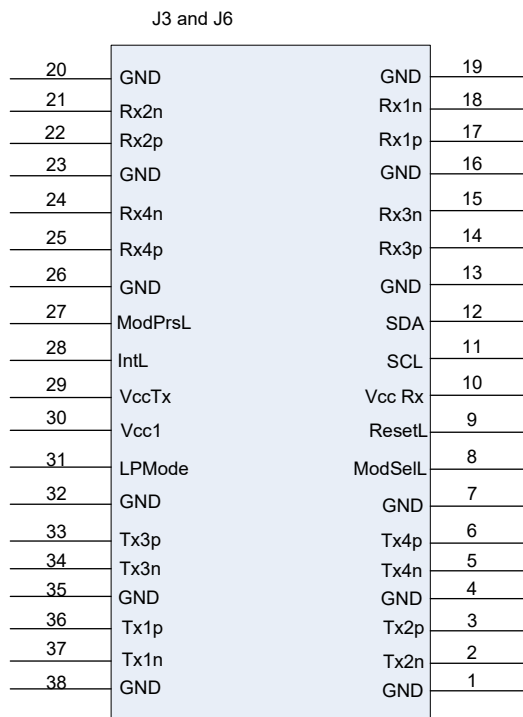
**Table 22 - InfiniBand QSFP Connector Pinout**

Connect or Pin Number	Connect or Pin Name	Signal Description
1	GND	Ground
2	Tx2n	Transmitter Inverted Data Input
3	Tx2p	Transmitter Non-Inverted Data Input
4	GND	Ground
5	Tx4n	Transmitter Inverted Data Input
6	Tx4p	Transmitter Non-Inverted Data Input
7	GND	Ground
8	Mod-SelL	Module Select
9	ResetL	Module Reset
10	Vcc Rx	+3.3 V Power supply receiver
11	SCL	2-wire serial interface clock
12	SDA	2-wire serial interface data
13	GND	Ground
14	Rx3p	Receiver Non-Inverted Data Output
15	Rx3n	Receiver Inverted Data Output
16	GND	Ground
17	Rx1p	Receiver Non-Inverted Data Output
18	Rx1n	Receiver Inverted Data Output
19	GND	Ground
20	GND	Ground
21	Rx2n	Receiver Inverted Data Output 3
22	Rx2p	Receiver Non-Inverted Data Output 3
23	GND	Ground
24	Rx4n	Receiver Inverted Data Output 3
25	Rx4p	Receiver Non-Inverted Data Output 3
26	GND	Ground
27	Mod-PrsL	Module Present
28	IntL	Interrupt

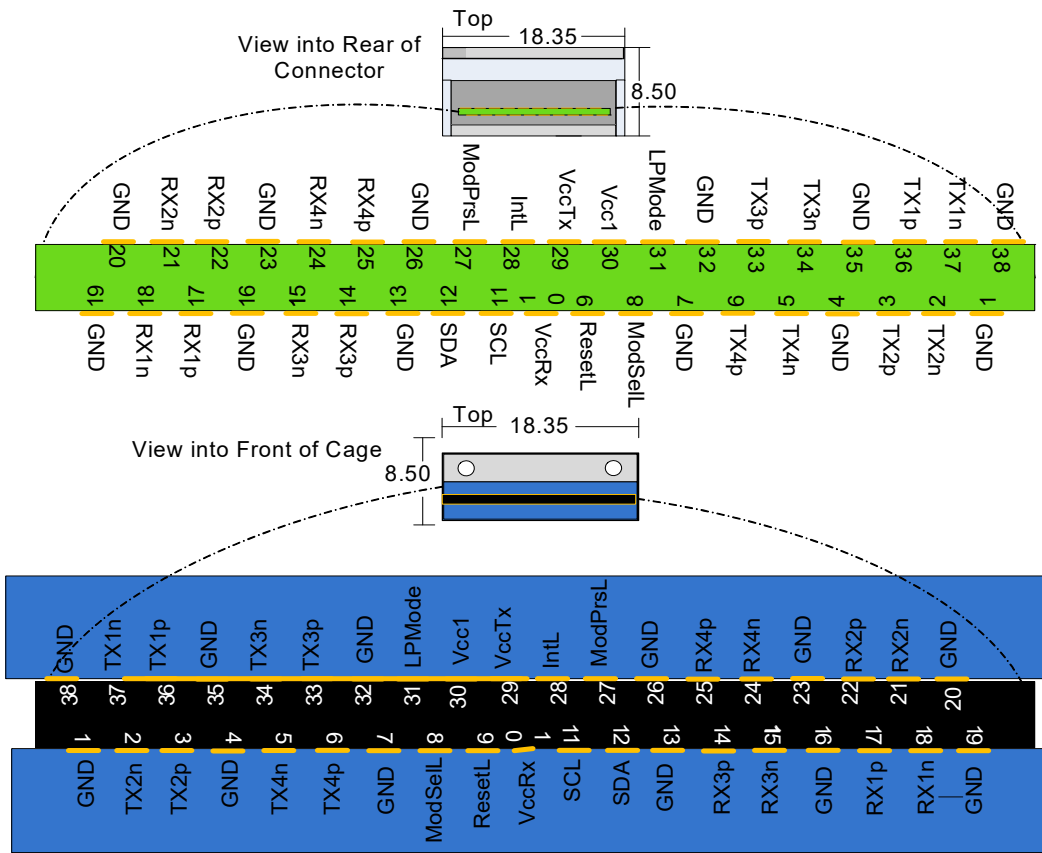
**Table 22 - InfiniBand QSFP Connector Pinout**

Connect or Pin Number	Connect or Pin Name	Signal Description
29	Vcc Tx	+3.3 V Power supply transmitter
30	Vcc 1	+3.3 V Power Supply
31	LPMode	Low Power Mode
32	GND	Ground
33	Tx3p	Transmitter Non-Inverted Data Input
34	Tx3n	Transmitter Inverted Data Input
35	GND	Ground
36	Tx1p	Transmitter Non-Inverted Data Input
37	Tx1n	Transmitter Inverted Data Input
38	GND	Ground

**Figure 73: InfiniBand QSFP Connector Symbol**



**Figure 74: QSFP Connector Male and Female Views**





## Appendix F: Replacement Parts Ordering Numbers

**Table 23 - Replacement Parts Ordering Numbers**

Part Description	OPN
Power supply unit PSU 1000W for Modular Switch Family	MTP005001
Power Supply unit PSU 1670W for Modular Switch Family	MTP006002
Power supply blank	MTM005001
Leaf board unit 18 port FDR	MSX6001FS
Leaf board unit 18 port FDR10	MSX6001TS
Modular Switch Family, Leaf - Blank	MTM005004
Spine board unit for FDR system	MSX6002FLS
Spine board unit for FDR10/QDR system	MSX6002TBS
Spine board blank	MTM005002
PPC460 Management Module	MSX6000MAR
x86 Management Module	MSX6000MBR
Modular Switch Family, Management - Blank	MTM005003
Rack Installation Kit for IS5600/SX6536 Series	MTR005600
IS5600/SX6536, IS5300/SX6518 Series Modular Switch, leaf cooling chassis fan unit located on Leaf Side	MTF005001
SX6536, SX6518, SX6512,MSX 6506 Modular Switch Series Spine Fan Unit	MTF005005
DB9 to RJ45 Harness	HAR000028
Power cord 250V 15A 2.0M C14 to C13	ACC000334
Power cord 125V 15A 2.0M C14 TO C13	ACC000242
Power cord Type B for USA, Canada, Mexico, Taiwan	ACC000204
Power cord Type H for Israel	ACC000205
Power cord Type E/F for Sweden, France, Germany, Netherlands, Russia	ACC000207
Power cord Type G for UK	ACC000208
Power cord Type D for India	ACC000209
Power cord Type I for China	ACC000210
Power cord Type J for Switzerland	ACC000211

**Table 23 - Replacement Parts Ordering Numbers (Continued)**

Part Description	OPN
Power cord Type B for Japan	ACC000212
Power cord Type I for Australia	ACC000213

## Appendix G: Safety Warnings (Multiple Languages)

### G.1 Nordic Countries Notices



Finland: “Laite on liitettävä suojakoskettimilla varustettuun pistorasiaan”  
Norway: “Apparatet må tilkoples jordet stikkontakt”  
Sweden: “Apparaten skall anslutas till jordat uttag”

### G.2 Installation Safety Warnings (English)

#### 1. Installation Instructions



Read all installation instructions before connecting the equipment to the power source.

#### 2. Bodily Injury Due to Weight



Use enough people to safely lift this product.

#### 3. Heavy Equipment



This equipment is heavy and should be moved using a mechanical lift to avoid injuries.

#### 4. Risk of Electric Shock!



Risk of Electric Shock!  
With the fan module removed power pins are accessible within the module cavity.  
DO NOT insert tools or body parts into the fan module cavity.

#### 5. Over-temperature



This equipment should not be operated in an area with an ambient temperature exceeding the maximum recommended: 45°C (113°F). Moreover, to guarantee proper , allow at least 8cm (3 inches) of clearance around the ventilation openings.

#### 6. Stacking the Chassis



The chassis should not be stacked on any other equipment. If the chassis falls, it can cause bodily injury and equipment damage.

## 7. Redundant Power Supply Connection - Electrical Hazard



This product includes a redundant power or a blank in its place. In case of a blank power supply, do not operate the product with the blank cover removed or not securely fastened.

## 8. Multiple Power Inlets



Risk of electric shock and energy hazard.  
The PSUs are all independent.

Disconnect all power supplies to ensure a powered down state inside of the switch platform.

## 9. During Lightning - Electrical Hazard



During periods of lightning activity, do not work on the equipment or connect or disconnect cables.

## 10. Copper InfiniBand Cable Connecting/Disconnecting



Copper InfiniBand cables are heavy and not flexible, as such they should be carefully attached to or detached from the connectors. Refer to the cable manufacturer for special warnings/instructions.

## 11. Rack Mounting and Servicing



When this product is mounted or serviced in a rack, special precautions must be taken to ensure that the system remains stable. In general you should fill the rack with equipment starting from the bottom to the top.

## 12. Equipment Installation



This equipment should be installed, replaced, and/or serviced only by trained and qualified personnel.

## 13. Equipment Disposal



Disposal of this equipment should be in accordance to all national laws and regulations.

## 14. Local and National Electrical Codes



This equipment should be installed in compliance with local and national electrical codes.

## 15. UL Listed and CSA Certified Power Supply Cord



For North American power connection, select a power supply cord that is UL Listed and CSA Certified, 3 - conductor, [16 AWG], terminated with a molded plug rated at 125 V, [13 A], with a minimum length of 1.5m [six feet] but no longer than 4.5m.

For European connection, select a power supply cord that is internationally harmonized and marked “<HAR>”, 3 - conductor, minimum 1.0 mm<sup>2</sup> wire, rated at 300 V, with a PVC insulated jacket. The cord must have a molded plug rated at 250 V, 10 A.

## 16. Installation codes



This device must be installed according to the latest version of the country national electrical codes. For North America, equipment must be installed in accordance to the applicable requirements in the US National Electrical Code and the Canadian Electrical Code.

## 17. Interconnection Of Units



Cables for connecting to the unit RS232 and Ethernet Interfaces must be UL certified type DP-1 or DP-2. (Note- when residing in non LPS circuit)

## 18. Overcurrent Protection



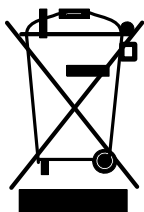
A readily accessible Listed branch circuit overcurrent protective device rated 20 A must be incorporated in the building wiring.

## 19. Do Not Use the Switch as a Shelf or Work Space



Caution: Slide/rail mounted equipment is not to be used as a shelf or a work space. The rails are not intended for sliding the unit away from the rack. It is for permanent installation at final resting place only, not used for service and maintenance

## 20. WEEE Directive



According to the WEEE Directive 2002/96/EC, all waste electrical and electronic equipment (EEE) should be collected separately and not disposed of with regular household waste.

Dispose of this product and all of its parts in a responsible and environmentally friendly way.

## 21. Country of Norway Power Restrictions



This unit is intended for connection to a TN power system and an IT power system of Norway only.

## G.3 אזהרות בטיחות בהתקנה (עברית)

### 1. הוראות התקנה



קרא היטב את כל הוראות ההתקנה לפני חיבור המוצר לחשמל.

### 2. תקן ישראלי



יש להתקין את המוצר תוך הקפדה על תקנות החשמל הנהוגות בישראל, ולעשות שימוש ביחידת חלוקת כוח העומדת בתקן ישראלי (ת"י) 32.

### 3. חבלת גוף כתוצאה מנשיאת משקל יתר



נדרשת נוכחותם של מספר מתקינים כדי להרים את המוצר בבטחה.

### 4. ציוד כבד



המוצר כבד ויש לשנעו באמצעות מעלית מכאנית כדי למנוע חבלה.

### 5. סכנת התחשמלות!



סכנת התחשמלות!

בעת שיחידת המאוורר מפורקת, רכיבי חשמל נחשפים בחלל הריק. אין להחדיר כלים או איברי גוף לחלל המיועד להרכבת היחידה.

## 6. התחממות יתר



אין להפעיל את המוצר באיזור שבו טמפרטורת החדר עולה על הטמפרטורה המקסימלית המומלצת: 45°C (113°F). בנוסף, כדי להבטיח כניסת אוויר תקינה, יש לוודא כי קיים שטח פנוי של 8 ס"מ (3 אינץ') לפחות סביב פתחי האיורור.

## 7. ערימת המערכת



אין לערום את המערכת על גבי ציוד אחר. במקרה של נפילה, עשויים להגרם נזקי גוף ורכוש.

## 8. חיבור ספק כוח נוסף - סכנת חשמל



המערכת מכילה ספק כוח נוסף לגיבוי או, בחלק מהמקרים, חלל ריק המאפשר הרכבת ספק כזה. אין לעשות שימוש במערכת כשהמכסה החוסם את החלל הריק אינו סגור כהלכה.

## 9. מספר שקעים חשמליים



סכנת התחשמלות ואזהרת אנרגיה. כל אחד מספקי הכוח פועל באופן עצמאי. יש לנתק את כל ספקי הכוח כדי להבטיח ניתוק מוחלט של המערכת מזרם חשמלי.

## 10. בעת סופות ברקים - סכנת חשמל



בעת סופות ברקים, אין להפעיל את המערכת או לחבר/לנתק כבלים.

## 11. חיבור או ניתוק של כבלי אינפיניבאנד מנחושת



כבלי InfiniBand מנחושת הם כבדים וקשיחים. לפיכך, יש לחברם ולנתקם מהמחברים בזהירות רבה. לאזהרות נוספות, יש לעיין בעלון לצרכן מטעם יצרן הכבלים.

## 12. הרכבה על גבי מדף בארון



כאשר מרכיבים מוצר זה על גבי מדף בארון, יש לנקוט באמצעי זהירות מיוחדים בכדי להבטיח שיוותר יציב. ככלל, יש למלא את מדפי הארון החל מהתחתון ועד לעליון.

## 13. התקנת המוצר



כל התקנה, החלפה או טיפול במוצר זה חייבת להתבצע על ידי איש צוות מיומן ומוסמך בלבד.

## 14. השלכת פסולת



השלכת המוצר בתום השימוש חייבת להיעשות בהתאם לכל התקנות והחוקים הלאומיים.

## 15. תקנות חשמל מקומיות ולאומיות



יש להתקין מערכת זו בהתאם לתקנות החשמל המקומיות והלאומיות.

## 16. כבל אספקת חשמל



על מנת לחבר את המוצר לחשמל בצפון אמריקה, יש לבחור כבל חשמלי מאושר UL ובעל הסמכת CSA, 3 - מוליך, [AWG 16], שבקצהו תקע מובנה 125V 13A, אורכו המינימלי 1.5 מטר (6 אינץ') ואורכו המקסימלי 4.5 מטר.

לחיבור אירופאי, בחר כבל חשמלי בעל התאמה בינלאומית וסימון "<HAR>", 3 - מוליך, גידים פנימיים באורך מינימלי של 1.0 מילימטר<sup>2</sup>, 300 V, עם עטיפת PVC מבודדת. על הכבל לכלול תקע מובנה 10A, V 250.

## 17. תקנות התקנה



יש להתקין מערכת זו על פי הגרסה האחרונה של תקנות החשמל הלאומיות הנהוגות במדינה. עבור צפון אמריקה, יש להתקין את המערכת בהתאם לתקנות החשמל הלאומיות המיושמות בארה"ב ובקנדה.



## 18. חיבור בין מערכות



על כבלים לחיבור היחידה לממשקי RS232 ו-Ethernet להיות בעלי הסמכת UL מסוג DP-1 או DP-2 (כאשר הם מצויים במעגל חשמלי שאינו מקור כוח מוגבל).

## 19. הגנה מפני מתח גבוה



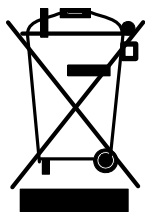
יש להקפיד על המצאותם בבניין ועל זמינותם של אמצעים להגנה מפני מתח גבוה בתקן 20A.

## 20. אין להשתמש במערכת כמדף או שטח עבודה



זהירות: אין להשתמש בציוד כמדף או שטח עבודה. המסילות לא נועדו לשליפת המערכת מהארון, אלא להתקנה במיקומו הקבוע והסופי של הארון.

## 21. תקנת WEEE



על פי תקנת WEEE 2002/96/EC, יש להשליך את כל פסולת הציוד החשמלי והאלקטרוני בנפרד מפסולת ביתית רגילה.

בתום השימוש, השלך לאשפה את המוצר הזה ואת כל חלקיו באופן אחראי וידידותי לסביבה.

## 22. מגבלות חשמליות בנורבגיה



יחידה זו מיועדת לחיבור למערכת אספקת חשמל מסוג TN ולמערכת אספקת חשמל מסוג IT, בנורבגיה בלבד.

## G.4 安裝安全性警告 (Chinese)

### 1. 安裝指示

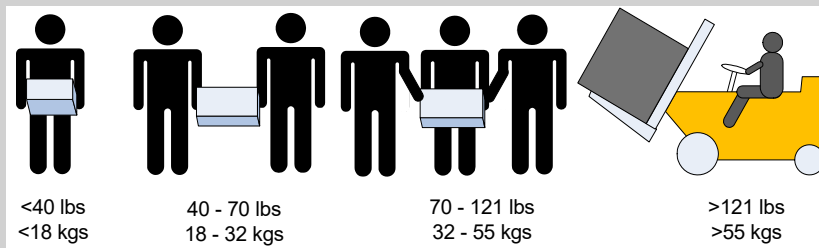


本設備附有備援電源供應器或在適當位置配有空白蓋板。

## 2. 因重量導致的人身受傷



為了安全起見，請安排足夠的人員以合力抬起本產品。



## 3. 重設備



本設備極重，應使用機械式起重機來搬移，以避免人員受傷。

## 4. 有觸電的危險



有觸電的危險！

拆除風扇模組後，即可接觸到模組空腔內的電源針腳。  
請勿將工具或機身零件插入到風扇模組空腔內。

## 5. 溫度過高



本設備不應在超過所建議的最高環境溫度的區域中運作：45°C (113°F)。此外，為了保證氣流的流通正常，請在通風口旁保留至少 8 公分 (3 英吋) 的間距。

## 6. 堆疊機箱



機箱不應堆疊在任何其他設備上。如果機箱掉落，可能造成人員受傷與設備損壞。

## 7. 複式電源連接時的電擊危險



本設備附有備援電源供應器或在適當位置配有空白蓋板。如果是電源供應器空白蓋板，在空白蓋板已取下或未牢牢固訂的情況下，請勿操作本產品。

## 8. 多電源輸入座



電擊與能源危害的危險。

所有 PSU 均各自獨立。

將所有電源供應器斷電，確保交換器平台內部在電源關閉狀態。

## 9. 閃電時的電擊危險



在閃電期間，不要使用本設備或連接或拔下纜線。

## 10. InfiniBand 銅纜連接 / 拔下



InfiniBand 銅纜很重且沒有彈性，因此必須小心裝在連接器上或自連接器上拔下。如需相關的特殊警告 / 指示，請洽詢纜線製造商。

## 11. 機架安裝與維修



此產品已安裝在機架中或在機架中維修時，必須採取特定預防措施以確保系統維持穩定。一般您應該將設備從底部到頂端放滿機架。

## 12. 設備安裝



本設備僅限由經過訓練與 / 或合格的人員安裝、更換或維修。

## 13. 設備棄置



棄置本設備應遵照所有國內法規。

## 14. 當地與國家電氣法規



請遵照當地與國家電氣法規安裝本設備。

## 15. UL 列名和 CSA 認證電源線



北美地區在接上電源時，請選用獲得 UL 列名和 CSA 認證、三個導體、[16 AWG] 附成型插頭，額定值為 125 V、[13 A]，長度至少 1.5 公尺 [六英尺]，但不超過 4.5 公尺的電源線。

歐洲地區在接上電源時，請選用國際協調式且標示有 <HAR> 字樣、三個導體、標稱截面至少 1.0 平方公厘，額定值為 300 V，採用 PVC 絕緣的電源線。電源線需有成型插頭，額定值為 250 V，10 A。

## 16. 高漏電流



警告：高漏電流；必須執行地線連接，然後再連接電源供應器。

## 17. 安裝法規



請務必遵循最新版的國家電氣法規，安裝本設備。在北美地區，請務必遵循美國國家電工法規和加拿大電工法規中的適用規定，安裝本設備。

## 18. 互連設備



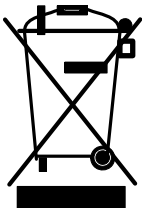
連接至 RS232 設備和乙太網路介面的纜線必須是 UL 認證類型 DP-1 或 DP-2。  
(請注意位於非 LPS 電路時)  
過電流保護：準備好使用的列名分支電路過電流保護裝置最大額定值 20 A 必須整合在配線中。

## 19. 切換開關不可用作機架或工作空間



小心：滑軌 / 導軌安裝設備不可用作機架或工作空間。導軌不適用於將設備滑出機架使用。僅限永久安裝在最後安置區域時使用，不可用於維修和保養。

## 20. WEEE 指令



根據 WEEE 指令 2002/96/EC，所有廢棄的電氣與電子設備 (EEE)，應分開集中，而且不應與一般家庭廢棄物一起棄置。  
請以負責和環保的方式棄置本產品及其所有零件。

## 21. 挪威國家電源限制



本設備僅限連接至挪威的 TN 電源系統和 IT 電源系統。

## G.5 Avertissements de sécurité pour l'installation (French)

### 1. Instructions d'installation

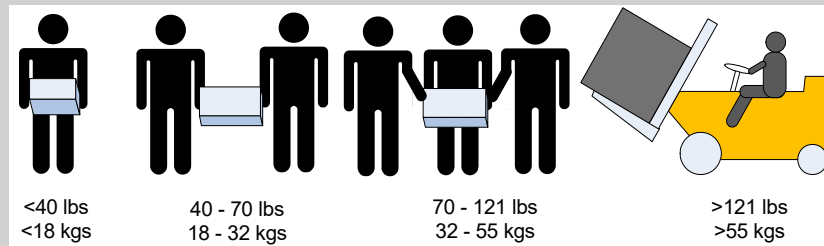


Veillez lire la totalité des instructions d'installation avant de relier l'équipement au secteur.

### 2. Blessures à cause du poids



Prévoyez assez de personnel pour soulever ce produit en toute sécurité.



### 3. Équipement lourd



Cet équipement est lourd et doit être déplacé avec un système de levage mécanique pour éviter les blessures.

### 4. Danger d'électrocution



Danger d'électrocution !

Lorsque le module de ventilation est retiré, les broches d'alimentation sont exposées dans l'emplacement du module.

NE PAS insérer d'outils ou la main dans l'emplacement du module.

### 5. Surchauffe



Cet équipement ne doit pas être en service dans un local dont la température dépasse le maximum recommandé de 45°C (113°F). En outre et pour garantir une circulation d'air correcte, laisser un espace d'au moins 8 cm (3") autour des orifices de ventilation.

### 6. Châssis empilé sur d'autres équipements



Le châssis ne doit pas être empilé sur d'autres équipements. S'il tombe, il peut endommager l'équipement ou entraîner des blessures.

## 7. Connexion de l'alimentation redondante : danger d'électrocution



Ce produit est équipé d'une alimentation redondante ou d'un cache si elle est absente. Dans ce dernier cas, ne pas faire fonctionner le produit si le cache est retiré ou mal fixé.

## 8. Plusieurs prises d'alimentation



Risque et danger d'électrocution.  
Les alimentations sont toutes indépendantes.  
Pour s'assurer que le commutateur est bien hors tension, débranchez toutes les alimentations.

## 9. En cas d'orage, danger d'électrocution



Pendant un orage, ne pas travailler sur l'équipement ni brancher ou débrancher des câbles.

## 10. Connexion et déconnexion du câble InfiniBand en cuivre



Les câbles InfiniBand en cuivre sont lourds et peu flexibles. Par conséquent, il faut procéder avec soin pour les brancher ou les débrancher des connecteurs. Consulter le fabricant du câble pour obtenir des instructions ou des avertissements spécifiques.

## 11. Montage en rack et maintenance



Lors du montage ou de la maintenance de ce produit dans un rack, il faut faire spécialement attention pour s'assurer que l'ensemble reste stable. En règle générale, le rack doit être rempli en commençant par le bas.

## 12. Installation de l'équipement



Cet équipement ne doit être installé, remplacé et maintenu que par un personnel formé et qualifié.

## 13. Mise au rebut de l'équipement



La mise au rebut de cet équipement doit se faire conformément à toutes les lois et réglementations nationales.

## 14. Codes électriques locaux et nationaux



Cet équipement doit être installé conformément aux codes électriques locaux et nationaux.

## 15. Codes d'installation



Cet appareil doit être installé conformément à la version la plus récente des codes électrique nationaux. En Amérique du Nord, l'équipement doit être installé en respectant les exigences de l'US National Electrical Code et du Code canadien de l'électricité.

## 16. Cordon d'alimentation UL Listed et certifié CSA



Pour le branchement électrique en Amérique du Nord, utiliser un cordon d'alimentation UL Listed et CSA Certified, à 3 conducteurs [calibre 16 AWG], avec une prise moulée 125 V [13 A], faisant au moins 1,5 m de long [six pieds] et au plus 4,5 m. Pour le branchement électrique en Europe, utiliser un cordon d'alimentation au format international harmonisé (marqué <HAR>), à 3 conducteurs d'au moins 1 mm<sup>2</sup> de section, 300 V, avec une gaine isolante en PVC. Le cordon doit avoir une prise moulée 250 V 10 A.

## 17. Courant de fuite élevé



**Avertissement** : courant de fuite élevé, une connexion à la terre est indispensable avant de brancher l'alimentation.

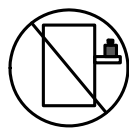
## 18. Interconnexion des unités



Les câbles de connexion aux interfaces RS232 et Ethernet de l'appareil doivent être certifié UL de type DP-1 ou DP-2. (Note : en cas d'installation sur un circuit dont la puissance n'est pas limitée)

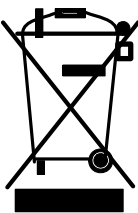
Protection contre les surintensités : le câblage de l'immeuble doit intégrer un dispositif certifié de protection contre les surintensités, calibré à 20 A et aisément accessible.

## 19. Ne pas utiliser comme étagère ou plan de travail



Attention : un équipement coulissant ou monté sur rail ne doit pas servir d'étagère ni de plan de travail. Les rails ne sont pas destinés à faire coulisser l'unité hors du rack. Ils sont destinés à une installation permanente à l'emplacement final, pas pour l'entretien ni la maintenance.

## 20. Directive DEEE



Selon la Directive 2002/96/CE (DEEE), tous les déchets d'équipements électriques et électroniques (EEE) doivent être collectés séparément et ne pas être mis au rebut avec les déchets ménagers habituels.

Ce produit et toutes ses pièces doivent être mis au rebut d'une manière responsable, respectant l'environnement.

## 21. Restrictions concernant l'alimentation pour la Norvège



Cet appareil est prévu pour être relié à un système d'alimentation TN et un système d'alimentation informatique de Norvège uniquement.

## G.6 Installation Sicherheitshinweise(German)

### 1. Installationsanleitungen

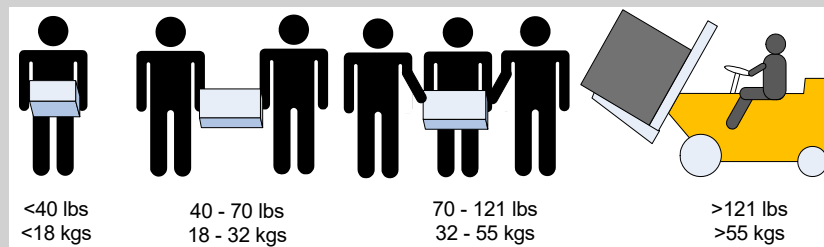


Lesen Sie alle Installationsanleitungen, bevor Sie das Gerät an die Stromversorgung anschließen.

### 2. Verletzungsgefahr wegen des Gewichts



Um das Produkt sicher anzuheben, genügend Personen einsetzen.



### 3. Schweres Gerät



Dieses Gerät ist schwer und muss mit einem mechanischen Hebegerät verschoben werden, um Verletzungen zu vermeiden.

### 4. Stromschlagrisiko



Stromschlagrisiko!

Bei abgenommenem Ventilatormodul sind die Stromkontakte in der Modulvertiefung zugänglich.

Es dürfen KEINE Werkzeuge oder Körperteile in die Vertiefung des Ventilatormoduls gelangen.

### 5. Übertemperatur



Dieses Gerät sollte nicht in einem Bereich mit einer Umgebungstemperatur über der maximal empfohlenen Temperatur von 45°C (113°F) betrieben werden. Es ist ein Luftstrom von 200 LFM bei maximaler Umgebungstemperatur erforderlich. Außerdem sollten mindestens 8 cm (3 in.) Freiraum um die Belüftungsöffnungen sein, um einen einwandfreien Luftstrom zu gewährleisten.



## 6. Stapeln des Chassis



Das Chassis sollte nicht auf andere Geräte gestapelt werden. Wenn das Chassis herun-  
terfällt, kann es zu Verletzungen und Beschädigungen an Geräten führen.

## 7. Mehrere Stromeingänge



Risiko eines Stromschlags und Stomgefahr.

Alle Stromversorgungseinheiten sind unabhängig.

Trennen Sie alle Stromversorgungen, um einen abgeschalteten Zustand im Inneren der  
Switch-Plattform sicherzustellen.

## 8. Bei Gewitter - Elektrische Gefahr



Arbeiten Sie während eines Gewitters und Blitzschlag nicht am Gerät, schließen Sie  
keine Kabel an oder ab.

## 9. Anschließen/Trennen von InfiniBand-Kupferkabel



InfiniBand-Kupferkabel sind schwer und nicht flexible. Deshalb müssen sie vorsichtig  
an die Anschlüsse angebracht bzw. davon getrennt werden. Lesen Sie die speziellen  
Warnungen und Anleitungen des Kabelherstellers.

## 10. Rack-Montage und Wartung



Wenn dieses Produkt in einem Rack montiert oder gewartet wird, sind besondere Vor-  
sichtsmaßnahmen zu ergreifen, um die Stabilität des Systems zu gewährleisten. Im  
Allgemeinen sollten Sie das Gestell von unten nach oben mit Geräten füllen.

## 11. Geräteinstallation



Diese Gerät sollte nur von geschultem und qualifiziertem Personal installiert, aus-  
getauscht oder gewartet werden.

## 12. Geräteentsorgung



Die Entsorgung dieses Geräts sollte unter Beachtung aller nationalen Gesetze Bestim-  
mungen erfolgen.

## 13. Regionale und nationale elektrische Bestimmungen



Dieses Gerät sollte unter Beachtung der regionalen und nationalen elektrischen Bes-  
timmungen installiert werden.

#### 14. Installationscodes



Dieses Gerät muss entsprechend der aktuellsten Version des National Electrical Code installiert werden. In Nordamerika muss das Gerät gemäß den geltenden Anforderungen des US National Electrical Code und des Canadian Electrical Code installiert werden.

#### 15. UL- und CSA-zertifiziertes Netzkabel



Für Nordamerika Stromanschluss, wählen Sie ein Netzkabel, das UL- und CSA Zertifiziert

3 - Leiter, [18 AWG], mit einem angespritztem Stecker bewertet bei 125 V, [15], mit einer Mindestlänge von 1,5 m [Six Feet] aber nicht mehr als 4,5 m.

Für die europäischen Zusammenhang, wählen Sie ein Netzkabel, das international harmonisiert und der Aufschrift "<HAR>",

3 - Leiter, mindestens 0,75 mm<sup>2</sup> Draht, bewertet mit 300 V, mit einem PVC-Mantel isoliert. Das Kabel muss eine angespritztem Stecker bewertet bei 250 V, 10 A. "

#### 16. Hoher Ableitstrom



WARNUNG: Hohe Ableitstrom; Earth Verbindung, bevor Sie die Verbindung von wesentlicher Bedeutung werden.

#### 17. Installationscodes



Dieses Gerät muss installiert sein, entsprechend auf die neueste Version des Landes National Electrical Code. Für Nordamerika, müssen in Übereinstimmung mit den geltenden Vorschriften in der US-amerikanischen National Electrical Code und dem Canadian Electrical Code.

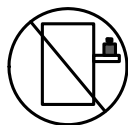
#### 18. Verbindung der Geräte untereinander



Kabel für den Anschluss an das Gerät RS232- und Ethernet-Schnittstellen müssen UL zertifiziert Typ DP-1 oder DP-2. (Hinweis-, wenn nicht mit Wohnsitz in LPS-Schaltung)

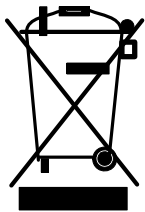
Überstromschutz: Eine leicht zugängliche Auflistung Abzweigung Überstrom-Schutzeinrichtung 20 A bewertet werden müssen in dem Gebäude Verkabelung.

#### 19. Switch nicht als Regal oder Arbeitsplatz nutzen



Achtung: Auf Schieber/Schienen montiertes Gerät ist nicht als Regal oder Arbeitsbereich zu nutzen. Die Schienen sind nicht dafür bestimmt, die Einheit aus dem Gestell weg zu ziehen. Sie sind nur für die permanente Installation an einem endgültigen Standort gedacht, nicht für Instandhaltung und Wartung.

## 20. WEEE-Direktive



Gemäß WEEE Directive 2002/96/EC müssen alle elektrischen und elektronischen Abfallgeräte (EEE) separat gesammelt und nicht mit normalem Haushaltsmüll entsorgt werden.

Dieses Produkt und alle seine Teile in verantwortungsvoller und umweltfreundlicher Art und Weise entsorgen.

## G.7 Advertencias de seguridad de instalación (Spanish)

### 1. Instrucciones de instalación

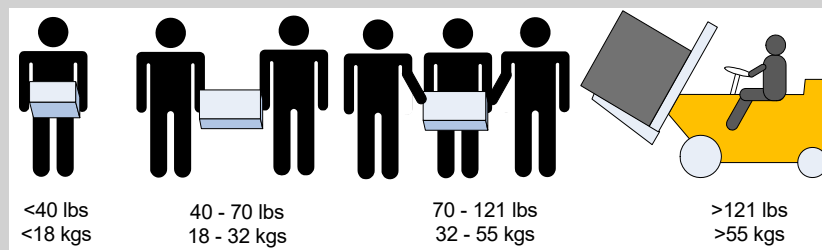


Antes de conectar el equipo a la fuente de alimentación, leer todas las instrucciones de instalación.

### 2. Lesión corporal a causa de peso



.Recorra a suficientes personas para levantar este producto sin



### 3. Equipos pesados



Dado que el equipo es pesado, se debe mover únicamente mediante un elevador mecánico, para evitar lesiones.

### 4. Riesgo de descarga eléctrica



¡Riesgo de descarga eléctrica!

Con el módulo del ventilador quitado, se obtiene acceso a las clavijas de alimentación desde dentro de la cavidad del módulo.

NO introducir herramientas ni partes del cuerpo en la cavidad del módulo del ventilador.

## 5. Sobretemperatura



No se debe utilizar el equipo en un área con una temperatura ambiente superior a la máxima recomendada: 45°C. Además, para garantizar una circulación de aire adecuada, se debe dejar como mínimo un espacio de 8 cm (3 pulgadas) alrededor de las aberturas de ventilación.

## 6. Apilamiento del chasis



Los chasis no se deben apilar sobre otros equipos. La caída del chasis podría causar lesiones corporales, así como daños al equipo.

## 7. Conexión redundante de fuente de alimentación: peligro de descarga



Este producto incluye una fuente de alimentación redundante o, en su lugar, una vacía. Si se dispone de una fuente de alimentación vacía, no utilizar el producto si su tapa está quitada o no está bien cerrada.

## 8. Tomas de alimentación múltiples



Riesgo de descarga eléctrica y peligro de corriente.  
Todas las fuentes de alimentación son independientes.  
Desconecte todas las fuentes de alimentación, para asegurar que no haya corriente alguna dentro de la plataforma de conmutación.

## 9. Al haber rayos: peligro de descarga



No utilizar el equipo ni conectar o desconectar cables durante períodos de actividad de rayos.

## 10. Cable de conexión y desconexión InfiniBand de cobre



Dado que los cables de cobre InfiniBand son pesados y no son flexibles, su conexión a los conectores y su desconexión se deben efectuar con mucho cuidado. Para ver advertencias o instrucciones especiales, consultar al fabricante del cable.

## 11. Montaje y mantenimiento del bastidor



Al instalar o realizar el mantenimiento de este aparato en un bastidor, es preciso adoptar precauciones especiales para garantizar que el sistema se mantenga estable. En general, en un bastidor, los equipos se deben instalar comenzando desde abajo hacia arriba.

## 12. Instalación del equipo



La instalación, el reemplazo y el mantenimiento de este equipo estarán a cargo únicamente de personal capacitado y competente.

## 13. Eliminación del equipo



La eliminación definitiva de este equipo se debe efectuar conforme a todas las leyes y reglamentaciones nacionales.

## 14. Códigos eléctricos locales y nacionales



Este equipo se debe instalar conforme a los códigos eléctricos locales y nacionales.

## 15. Códigos de instalación



Este dispositivo se debe instalar conforme a la versión más reciente de los códigos eléctricos nacionales del país en cuestión. En América del Norte, el equipo se debe instalar de acuerdo con las disposiciones vigentes del Código Eléctrico Nacional de los EE.UU. y del Código Eléctrico de Canadá.

## 16. Cable de alimentación homologado por UL y con certificación CSA



En conexiones de América del Norte, seleccionar un cable de alimentación homologado por UL y con certificación CSA de tres conductores, [16 AWG], terminado en un enchufe moldeado con capuchón de 125 voltios nominal, [13 A], con una longitud mínima de 1,5 metros, pero no más de 4,5 metros.

En conexiones europeas, seleccionar un cable de alimentación armonizado internacionalmente y marcado "<HAR>", de tres conductores, hilo de 1,0 mm<sup>2</sup> como mínimo, 300 voltios nominal, con cobertura protectora aislante de PVC. El cable debe tener un enchufe moldeado con capuchón de 250 voltios nominal, 10 A.

## 17. Alta corriente de fuga



**ADVERTENCIA:** Alta corriente de fuga. Es esencial efectuar la conexión a tierra antes de conectar la alimentación.

## 18. Códigos de instalación



Este dispositivo se debe instalar conforme a la versión más reciente de los códigos eléctricos nacionales del país en cuestión. En América del Norte, el equipo se debe instalar de acuerdo con las disposiciones vigentes del Código Eléctrico Nacional de los EE.UU. y del Código Eléctrico de Canadá.

## 19. Interconexión de unidades



Los cables para la conexión con las interfaces RS232 y Ethernet de la unidad deben estar homologados por UL tipo DP-1 o DP-2. (Nota: cuando residen en circuito no de tipo LPS)

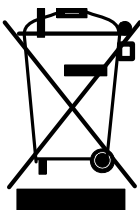
Protección contra sobrecargas: Al cableado del edificio se debe incorporar un dispositivo de protección contra sobrecargas de circuito derivado, de fácil acceso, con una corriente nominal de 20 A.

## 20. No utilizar el conmutador como estante ni como espacio de trabajo



Cuidado: Equipos montados en deslizadores o rieles no se deben utilizar como estantes ni como espacio de trabajo. La finalidad de los rieles no es deslizar la unidad hacia afuera del bastidor. Sirven solo para la instalación permanente en el lugar de destino final, no para fines de servicio o mantenimiento

## 21. Directiva WEEE



Conforme a la Directiva 2002/96/CE sobre RAEE, todos los residuos de equipos eléctricos y electrónicos (EEE) se deben recolectar por separado y no se deben eliminar junto con residuos domésticos.

Al deshacerse de este producto y de todas sus partes, hágalo de una manera responsable y respetuosa con el medio ambiente.

## G.8 Предупреждения по технике безопасности при установке (Russian)

### 1. Инструкция по установке

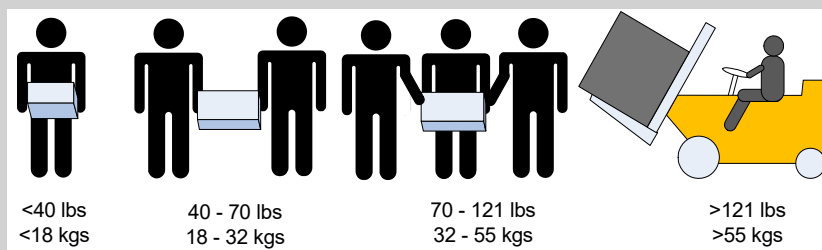


Перед подключением оборудования к источнику питания следует ознакомиться с инструкцией по установке.

### 2. Травмы при переносе тяжелых предметов



Для поднятия этого изделия следует задействовать достаточное количество людей.



### 3. Тяжелое оборудование



Это тяжелое оборудование, поэтому его следует перемещать с помощью механического подъемника во избежание травм.

### 4. Опасность поражения электрическим током



Опасность поражения электрическим током!

Когда снят вентиляторный модуль, существует возможность повреждения контактов питания в его углублении.

НЕ вставлять инструменты или части тела в углубление вентиляторного модуля.

### 5. Перегрев



Не эксплуатировать это оборудование в помещении с температурой окружающей среды, превышающей максимально рекомендуемое значение: 45 °C (113 °F).

Более того, для надлежащей вентиляции следует обеспечить зазор вокруг вентиляционных отверстий не менее 8 см (3 дюйма).

### 6. Установка шасси поверх другого оборудования



Не устанавливать шасси поверх другого оборудования. Падение шасси может привести к травмам и повреждению оборудования.

### 7. Опасность поражения электрическим током резервного источника питания



В этом изделии установлен резервный источник питания или модуль-заглушка. Если установлен модуль-заглушка, не эксплуатировать изделие со снятой или ненадежно закрепленной крышкой модуля-заглушки.

### 8. Несколько источников питания



Опасность поражения электрическим током и опасные энергетические воздействия.

Блоки питания независимы друг от друга.

Чтобы обесточить все компоненты внутри платформы коммутации, следует отсоединить все блоки питания.

### 9. Опасность поражения электрическим током во время грозы



Во время грозы запрещается использовать оборудование и подключать или отключать кабели.

## 10. Подсоединение и отсоединение медных кабелей InfiniBand



Медные кабели InfiniBand тяжелые и негибкие, поэтому следует осторожно их подсоединять и отсоединять. За особыми предупреждениями и указаниями следует обратиться к производителю кабеля.

## 11. Установка или обслуживание в стойке



При установке или обслуживании этого изделия в стойке следует обеспечить устойчивость системы. Как правило, стойка заполняется оборудованием снизу вверх.

## 12. Установка оборудования



Устанавливать, заменять и/или обслуживать это оборудование должен только подготовленный и квалифицированный персонал.

## 13. Утилизация оборудования



Это оборудование утилизируется в соответствии с национальными законами и постановлениями.

## 14. Местные и национальные правила установки электрооборудования



Это оборудование устанавливается в соответствии с местными и национальными правилами установки электрооборудования.

## 15. Правила установки электрооборудования



Это устройство устанавливается в соответствии с последним изданием национальных правил установки электрооборудования. В Северной Америке оборудование устанавливается в соответствии с действующими требованиями Национальных правил эксплуатации и обслуживания электрических установок США и Канады.

## 16. Шнур питания, включенный в номенклатуру UL и сертифицированный Канадской ассоциацией стандартизации (CSA)



Подключение к электропитанию в Северной Америке выполняется с помощью шнура питания, включенного в номенклатуру UL и сертифицированного Канадской ассоциацией стандартизации (CSA), 3-жильного, [16 AWG], длиной от 1,5 м [6 футов] до 4,5 м, с литой вилкой, рассчитанной на 125 В [13 А].  
Подключение к электропитанию в Европе выполняется с помощью гармонизированного шнура питания с маркировкой <HAR>, 3-жильного, с сечением жилы не менее 1,0 мм<sup>2</sup>, рассчитанного на номинальное напряжение 300 В, с ПВХ оболочкой. Шнур должен иметь литую вилку, рассчитанную на 250 В, 10 А.



## 17. Высокий ток утечки



Осторожно! Высокий ток утечки. Заземлить перед подключением к электропитанию.

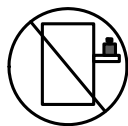
## 18. Подсоединение устройств



Для подключения к разъемам RS232 и Ethernet используются кабели типа DP-1 или DP-2, сертифицированные организацией UL. (Примечание. При подключении к сети без ограниченного источника электропитания)

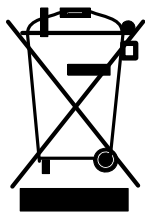
Максимальная токовая защита. В проводку здания в легкодоступном месте следует включить устройство защиты от перегрузки по току номиналом 20 А.

## 19. Не использовать коммутатор как полку или рабочую



Внимание! Оборудование, установленное на направляющих, не должно использоваться как полка или рабочая поверхность. Направляющие не предназначены для удерживания устройства, выдвинутого из стойки. Они предназначены для стационарной установки только в конечном положении и не используются для обслуживания устройства.

## 20. Директива WEEE



В соответствии с Директивой 2002/96/EC (WEEE) отходы электрического и электронного оборудования должны собираться и утилизироваться отдельно от обычных бытовых отходов.

Следует утилизировать это изделие и все его части ответственным и экологически безопасным способом.

## G.9 Avertismente privind siguranța la instalare (Romanian)

### 1. Instrucțiuni de instalare

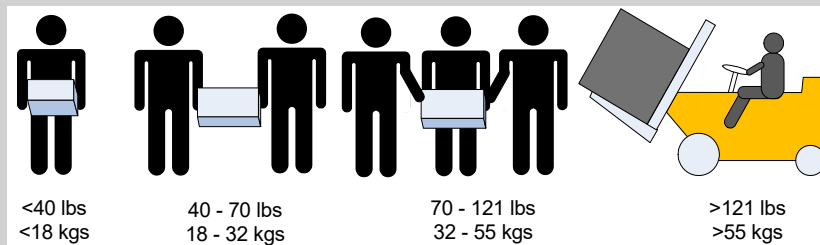


Citiți toate instrucțiunile de instalare înainte de a conecta

## 2. Accidentare cauzată de greutate



Apelați la un număr suficient de persoane pentru a ridica în siguranță acest produs.



## 3. Echipament greu



Acest echipament este greu și trebuie să fie mutat folosind un dispozitiv mecanic de ridicare pentru a evita producerea de leziuni.

## 4. Risc de șoc electric



Risc de șoc electric!

Odată ce modulul ventilator este îndepărtat, pinii electrici sunt accesibili în cavitatea modulului.

NU introduceți instrumente sau părți din corp în cavitatea modulului ventilator.

## 5. Temperatură în exces



Acest echipament nu trebuie să fie acționat într-o zonă unde temperatura ambiantă depășește valoarea maximă recomandată: 45°C (113°F). În plus, pentru a asigura un flux de aer adecvat, lăsați un spațiu liber de cel puțin 8 cm (3 inchi) în jurul fanțelor de ventilare.

## 6. Suprapunerea cadrului



Cadrul nu trebuie să fie suprapus peste niciun alt echipament. În cazul în care cadrul cade, poate cauza leziuni corporale și deteriorări ale echipamentului.

## 7. Conexiunea la o sursă de alimentare electrică suplimentară - pericol electric



Acest produs include o sursă de alimentare suplimentară sau un spațiu gol în locul acesteia. În cazul în care spațiul pentru sursa de alimentare este gol, nu operați produsul când capacul orb este îndepărtat sau nu este fixat în mod sigur.

## 8. Multiple mufe electrice



Risc de șoc electric și pericol electric.

Toate aparatele cu alimentare de la rețea sunt independente.

Deconectați toate sursele de alimentare cu energie pentru a asigura decuplarea în interiorul platformei de comutare.

## 9. În timpul descărcărilor electrice - pericol electric



În timpul perioadelor cu descărcări electrice luminoase, nu lucrați cu echipamentul sau nu conectați sau deconectați cablurile.

## 10. Conectarea/deconectarea cablului din cupru InfiniBand



Cablurile InfiniBand din cupru sunt grele și inflexibile, de aceea trebuie să fie atașate sau detașate de conectori cu grijă. Consultați producătorul de cabluri pentru avertismente/instrucțiuni speciale.

## 11. Montarea sau depanarea într-un rack



Când acest produs este montat sau depanat într-un rack, trebuie să fie luate măsuri de precauție speciale pentru a se asigura că sistemul rămâne stabil. În general, trebuie să umpleți rack-ul cu echipamente începând de jos în sus.

## 12. Instalarea echipamentului



Acest echipament trebuie să fie instalat, înlocuit și/sau depanat numai de către personal instruit și calificat.

## 13. Eliminarea echipamentului



Eliminarea acestui echipament trebuie să se realizeze în conformitate cu toate legile și regulamentele naționale.

## 14. Codurile electrice locale și naționale



Acest echipament trebuie să fie instalat conform codurilor electrice locale și naționale.

## 15. Codurile ed instalare



Acest dispozitiv trebuie să fie instalat în conformitate cu ultima versiune a codurilor electrice naționale ale țării în cauză. Pentru America de Nord, echipamentul trebuie să fie instalat conform cerințelor aplicabile din Codul electric național al SUA și Codul electric canadian.

## 16. Cordon de alimentare electrică înregistrat UL și certificat CSA



Pentru conectarea la o sursă de alimentare pentru America de Nord, selectați un cordon de alimentare care este înregistrat UL și certificat CSA, cu 3 conductoare, [16 AWG], terminat cu o fișă turnată, cu putere nominală egală cu 125 V, [13 A], cu o lungime de minimum 1,5 m [șase picioare], dar nu mai lung de 4,5 m.

Pentru conectarea la o sursă de alimentare în Europa, selectați un cordon de alimentare care este armonizat la nivel internațional și marcat „<HAR>”, cu 3 conductoare, cu minimum 2 fire de 1,0 mm, cu putere nominală egală cu 300 V și cu o manta izolantă din PVC. Cordonul de alimentare trebuie să fie prevăzut cu o fișă turnată cu putere nominală egală cu 250 V, 10 A.

## 17. Curent de scurgere de înaltă frecvență



Avertisment: Curent de scurgere de înaltă frecvență; Împământarea este esențială înainte de a conecta sursa de alimentare.

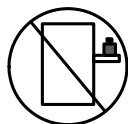
## 18. Interconectarea unităților



Cablurile pentru conectarea la unitatea RS232 și la interfețele Ethernet trebuie să fie de tipul DP-1 sau DP-2 certificate UL. (Notă- când se regăsesc într-un circuit non-LPS)

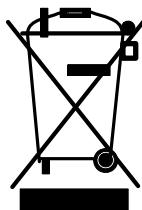
Protecție la supracurent: Un dispozitiv de protecție la supracurent, înregistrat în circuitul de ramificare, ușor accesibil și cu o putere nominală egală cu 20 A trebuie să fie integrat în cablajul clădirii.

## 19. Nu utilizați comutatorul ca raft sau spațiu de lucru



Atenție: Echipamentul montat pe o linie de alunecare/șină nu va fi utilizat ca raft sau spațiu de lucru. Scopul șinelor nu este de a glisa unitatea de pe rack. Acestea sunt destinate instalării permanente numai la punctul final de oprire și nu vor fi folosite pentru depanare și întreținere

## 20. Directiva DEEE



În conformitate cu Directiva DEEE 2002/96/CE, toate deșeurile de echipamente electrice și electronice (EEE) trebuie colectate separat și nu trebuie eliminate împreună cu deșeurile menajere obișnuite.

Eliminați acest produs și toate componentele sale în mod responsabil și ecologic.

## G.10 Sigurnosna upozorenja za instaliranje (Croatian)

### 1. Upute za instaliranje

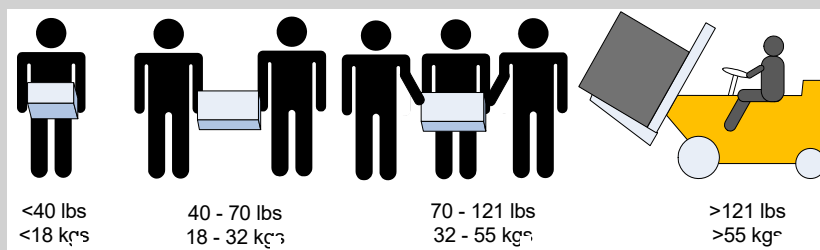


Pažljivo pročitajte upute za instaliranje prije spajanja opreme na izvor električne energije.

### 2. Tjelesne ozljede uslijed težine



Kako biste sigurno podignuli ovaj proizvod, koristite dovoljan broj ljudi.



### 3. Teška oprema



Ova oprema je vrlo teška i treba se premještati pomoću mehaničkog dizala kako bi se izbjegle ozljede.

### 4. Rizik od strujnog udara!



Rizik od strujnog udara!

S uklonjenim modulom ventilatora, perima napajanja se može pristupiti u otvoru modula.

NEMOJTE umetati alat ili dijelove tijela u otvor modula ventilatora.

### 5. Pregrijavanje



Ovom se opremom ne bi trebalo rukovati u područjima s temperaturom okoline koja premašuje najviše preporučene vrijednosti: 45°C (113°F). Osim toga, kako bi se osigurao odgovarajući protok zraka, omogućite najmanje 8 cm (3 inča) razmaka oko otvora ventilatora.

### 6. Slaganje kućišta



Kućište se ne bi trebalo slagati na drugu opremu. Ako kućište padne, može izazvati tjelesne ozljede i oštećenje opreme.

## 7. Redundantno napajanje - Opasnost od električne energije



Ovaj proizvod uključuje redundantno napajanje ili prazan prostor na njegovu mjestu. U slučaju praznog prostora za napajanje, nemojte rukovati proizvodom ako je poklopac uklonjen ili ako nije dobro pričvršćen.

## 8. Višestruki ulazi za napajanje



Rizik od strujnog udara i opasnost od električne energije.

PSU jedinice su neovisne.

Odspojite sva napajanja kako biste osigurali stanje bez napajanja unutar platforme preklopnika.

## 9. Tijekom udara munje - Opasnost od električne energije



Tijekom djelovanja munja, nemojte raditi na opremi ili spajati ili odspajati kabele.

## 10. Spajanje/Odspajanje bakrenog kabela InfiniBand



Bakreni kabele InfiniBand su teški i nesavitljivi i kao takvi se moraju pažljivo priključiti na ili isključiti iz konektora. Obratite se proizvođaču kabela za posebna upozorenja/upute.

## 11. Montaža ormarića i servisiranje



Kad se proizvod montira ili se servisira u ormariću, moraju se poduzeti posebne mjere opreza kako bi se osiguralo da sustav ostane stabilan. Općenito, trebali biste ispunjavati ormarić s opremom počevši od dna prema vrhu.

## 12. Instaliranje opreme



Ovu bi opremu trebalo instalirati, zamjenjivati i/ili servisirati samo obučeno i kvalificirano osoblje.

## 13. Odlaganje opreme



Odlaganje opreme trebalo bi se vršiti sukladno nacionalnim zakonima i propisima.

## 14. Lokalni i nacionalni električni kodovi



Ova oprema trebala bi se instalirati u skladu s lokalnim i nacionalnim električnim kodovima.

## 15. Instalacijski kodovi



Ovaj se uređaj mora instalirati sukladno najnovijoj verziji nacionalnih električnih kodova države. U Sjevernoj Americi oprema se mora instalirati sukladno važećim zahtjevima navedenim u US National Electrical Code i Canadian Electrical Code.

## 16. UL CSA kabel napajanja



Za sjevernoameričku mrežu odaberite kabel napajanja koji je na UL listi i sa CSA certifikatom, 3 - žilni, [16 AWG] (16 AWG) koji završava lijevanim utikačem nazivnog napona od 125 V, [13 A], minimalne duljine od 1,5 m [six feet] (šest stopa), ali ne dulji od 4,5 m.

Za europsku mrežu odaberite kabel napajanja koji je međunarodno usklađen i označen “<HAR>”, 3 - žilni, s najmanje 1,0 mm<sup>2</sup> žice, nazivnog napona od 300 V, s PVC izolacijom. Kabel mora imati lijevani utikač nazivnog napona od 250 V, nazivne struje od 10 A.

## 17. Veliko curenje struje



**Upozorenje:** Veliko curenje struje; Prije spajanja napajanja nužno je spojiti uzemljenje.

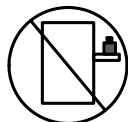
## 18. Interkonekcija uređaja



Kabli za spajanje na jedinicu RS232 i Ethernet sučelja moraju biti s UL certifikatom vrste DP-1 ili DP-2. (Napomena - kad se nalazi u krugu bez LPS vodiča)

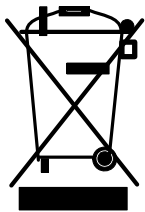
Zaštita od strujnog preopterećenja: Uvijek dostupni odobreni zaštitni uređaji od strujnog preopterećenja nazivne struje od 20 A moraju se ugraditi u ožičenje zgrade.

## 19. Nemojte koristiti preklopnik kao policu ili radnu površinu



Pozor: Oprema montirana na klizače/vodilice ne bi se trebala koristiti kao policu ili radna površina. Vodilice nisu namijenjene za povlačenje uređaja iz ormarića. Služe samo za trajnu instalaciju na konačnom položaju, a ne za servisiranje i održavanje.

## 20. WEEE direttiva



Sukladno WEEE direktivi 2002/96/EZ, sav električni i elektronički otpad (EEE) trebao bi se prikupljati zasebno i ne bi se trebao odlagati kao običan kućanski otpad. Odlaganje ovog proizvoda i svih njegovih dijelova vršite na odgovoran i ekološki način.

## 21. Električna ograničenja države Norveške



Ovaj je uređaj namijenjen samo za spajanje na električni sustav s TN uzemljenjem i na električni sustav s IT uzemljenjem države Norveške.

## G.11 Avvertenze di sicurezza per l'installazione (italiano)

### 1. Istruzioni di installazione

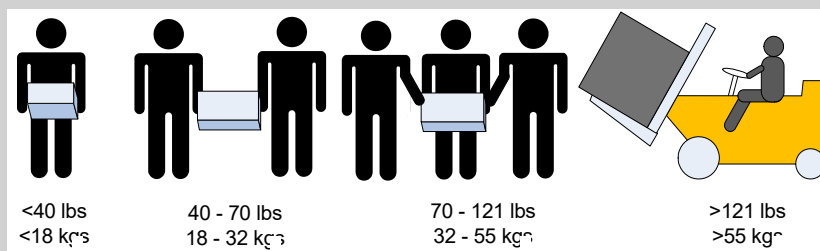


Leggere tutte le istruzioni di installazione prima di collegare l'apparecchiatura all'alimentazione.

### 2. Lesioni a causa del peso



Usare un numero di persone sufficiente per sollevare in sicurezza questo prodotto.



### 3. Apparecchiatura pesante



Questa apparecchiatura è molto pesante e va spostata mediante un sollevatore meccanico, per evitare lesioni.



#### 4. Rischio di scosse elettriche!



Rischio di scosse elettriche!

Con il modulo ventola rimosso, i pin di alimentazione sono accessibili all'interno della cavità del modulo.

NON inserire strumenti o parti del corpo nella cavità del modulo della ventola.

#### 5. Temperatura eccessiva



Questa apparecchiatura non va utilizzata in un'area con una temperatura ambiente superiore a quella massima consigliata: 45 °C (113 °F). Inoltre, per assicurare un flusso d'aria adeguato, lasciare almeno 8 cm (3 pollici) di spazio attorno alle aperture di ventilazione.

#### 6. Impilare lo chassis



Kućište se ne bi trebalo slagati na drugu opremu. Ako kućište padne, može izazvati tjelesne ozljede i oštećenje opreme.

#### 7. Collegamento di alimentazione ridondante - Pericoli elettrici



Questo prodotto è dotato di un alimentatore ridondante o, qualora esso non sia installato, di uno spazio vuoto. Qualora l'alimentatore non sia installato, non utilizzare il prodotto con il coperchio rimosso o non fissato correttamente.

#### 8. Prese di alimentazione multiple



Rischio e pericolo di scosse elettriche.

Gli alimentatori sono tutti indipendenti.

Scollegare tutti gli alimentatori per assicurarsi che il commutatore non sia sotto tensione

#### 9. Durante i temporali, pericolo di scosse elettriche



Durante i temporali, non effettuare interventi sull'apparecchiatura e non collegare o scollegare i cavi.

#### 10. Collegamento/scollegamento del cavo di rame InfiniBand



I cavi di rame InfiniBand sono pesanti e non flessibili. Di conseguenza, vanno collegati o scollegati con cura dai connettori. Per avvertenze/istruzioni speciali, rivolgersi al produttore di cavi.

## 11. Montaggio su rack e manutenzione



Quando questo prodotto viene montato o sottoposto a manutenzione su un rack, è necessario adottare delle precauzioni speciali per assicurarsi che il sistema resti stabile. In generale, il rack va riempito con apparecchiature, procedendo dal basso verso l'alto.

## 12. Installazione dell'apparecchiatura



Questa apparecchiatura va installata, sostituita e/o sottoposta a manutenzione solo da personale addestrato e qualificato.

## 13. Smaltimento dell'apparecchiatura



Lo smaltimento di questa apparecchiatura va effettuato in conformità con tutte le leggi e le normative nazionali.

## 14. Codici elettrici locali e nazionali



Questa apparecchiatura va installata in conformità con le norme elettriche locali e nazionali.

## 15. Codici di installazione



Questo dispositivo va installato in conformità con l'ultima versione dei codici elettrici nazionali del Paese. Per il Nord America, l'apparecchiatura va installata in conformità con i requisiti applicabili del "codice elettrico nazionale USA" e del "codice elettrico canadese".

## 16. Cavo di alimentazione UL e munito di certificazione CSA



Per una connessione di alimentazione nordamericana, selezionare un cavo di alimentazione di tipo UL e munito di certificazione CSA, a 3 conduttori, [16 AWG], terminato con una spina stampata con tensione nominale pari a 125 V, [13 A], di lunghezza minima pari a 1,5 m [sei piedi] ma non più lunga di 4,5 m.  
Per una connessione europea, selezionare un cavo di alimentazione armonizzato a livello internazionale e contrassegnato da "<HAR>", a 3 conduttori, minimo 1,0 mm<sup>2</sup> fili, con guaina isolante in PVC. Il cavo deve disporre di una spina stampata di potenza nominale pari a 250 V, 10 A.

## 17. Corrente di dispersione elevata



**Avvertenza:** corrente di dispersione elevata; il collegamento a terra è essenziale prima di collegare l'alimentazione.

## 18. Interconnessione delle unità



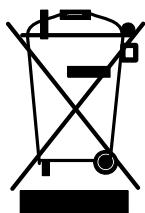
I cavi per il collegamento all'unità RS232 e alle interfacce Ethernet devono disporre della certificazione UL ed essere del tipo DP-1 o DP-2. (Nota: in caso di installazione su un circuito la cui potenza non è limitata)  
Protezione contro le sovracorrenti: la cablatura dell'edificio deve integrare un dispositivo di protezione contro le sovracorrenti di potenza nominale pari a 20.

## 19. Non utilizzare lo switch come scaffale o piano di lavoro



Attenzione: un'apparecchiatura scorrevole o montata su binari non va utilizzata come scaffale o piano di lavoro. I binari non sono progettati per far scorrere e allontanare l'unità dal rack. Essi sono destinati all'installazione permanente solo nel luogo di lavoro e non vengono utilizzati per assistenza e manutenzione

## 20. Direttiva RAEE



Secondo la direttiva RAEE 2002/96/EC, tutti i rifiuti da apparecchiature elettriche ed elettroniche (RAEE) vanno raccolti separatamente e non smaltiti nei normali rifiuti domestici.

Smaltire questo prodotto e tutte le sue parti in modo responsabile e rispettoso dell'ambiente

## 21. Limitazioni relative all'alimentazione per la Norvegia



Questa apparecchiatura è progettata esclusivamente per il collegamento a un sistema di alimentazione TN e a un sistema di alimentazione IT.

## G.12 Montaj Güvenlik Uyarıları (Türkçe)

### 1. Montaj Talimatları

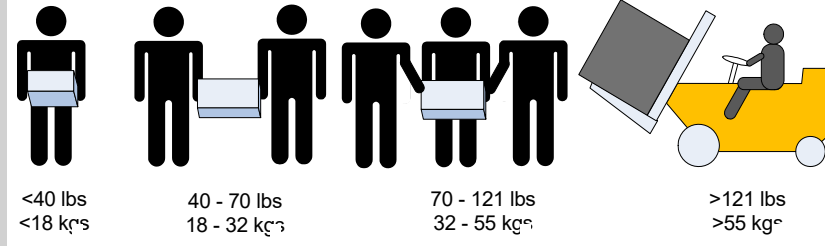


Ekipmanı güç kaynağına bağlamadan önce tüm montaj talimatlarını okuyun.

### 2. Ağırlık Nedeniyle Fiziksel Yaralanma



Bu ürünü güvenli bir şekilde kaldırmak için yeterli sayıda insandan yardım alın..



### 3. Ağır Ekipman



Bu ekipman çok ağırdır ve yaralanmaları önlemek için ekipmanın mekanik asansör kullanılarak taşınması gerekir.

### 4. Elektrik Çarpması Riski!



Bu ekipman, önerilen maksimum ortam sıcaklığını aşan alanlarda çalıştırılmamalıdır: 45 °C (113 °F). Ayrıca, düzgün hava akışı sağlamak için havalandırma deliklerinin etrafında en az 8 cm (3 inç) açıklık bırakılmalıdır.

### 5. Aşırı Isınma



Bu ekipman, önerilen maksimum ortam sıcaklığını aşan alanlarda çalıştırılmamalıdır: 45 °C (113 °F). Ayrıca, düzgün hava akışı sağlamak için havalandırma deliklerinin etrafında en az 8 cm (3 inç) açıklık bırakılmalıdır.

### 6. Şasi İstif



Şasinin diğer herhangi bir ekipmanın üzerine istiflenmemesi gerekir. Şasi düşerse, fiziksel yaralanmalara ve ekipmanda hasara neden olabilir.

## 7. Yedekli Güç Kaynağı Bağlantısı -Elektrik Çarpma Tehlikesi



Bu ürün, yedekli güç kaynağı veya onun yerine boş elektrik kutusu içerir. Güç kaynağı için boş elektrik kutusu varsa, kutunun kapağı açıkken veya tam olarak kapatılmamışken ürünü çalıştırmayın.

## 8. Çoklu Güç Girişleri



Elektrik çarpması riski ve enerji tehlikesi.  
Bütün PSU'lar (Güç Kaynağı Üniteleri) ayrıdır.  
Anahtar platformundaki gücü kapatmak için tüm güç kaynaklarının bağlantılarını kesin.

## 9. Şimşek - Elektrik Çarpma Tehlikesi



Gökyüzünde şimşek çaktığı zamanlarda, ekipman üzerinde çalışmayın veya kablo bağlamayın ya da kablo bağlantısı kesmeyin.

## 10. Bakır İnfiband Kablo Bağlama/Bağlantıyı Kesme



Bakır İnfiband kablolar ağırdır ve esnemezler. Bu nedenle, bağlantılara çok dikkatli bir şekilde takılmaları veya çıkarılmaları gerekir. Özel uyarılar/talimatlar için kablo üreticinize başvurun.

## 11. İskele Montajı ve Bakım



Bu ürün bir iskelede monte edildiyseniz veya bir iskele ile sunulduysa, sistemin sabit kalması için özel önlemler alınmalıdır. Genelde, ekipmanları iskeleye aşağıdan yukarı doğru doldurmanız gerekir.

## 12. Ekipman Montajı



Ekipmanın yalnızca eğitimli ve nitelikli personel tarafından monte edilmesi, değiştirilmesi ve/veya bakımının yapılması gerekir.

## 13. Ekipmanın Atılması



Bu ekipmanın imhasında tüm ulusal yasalara ve düzenlemelere uyulması gerekir.

## 14. Yerel ve Ulusal Elektrik Kodları



Bu ekipmanın montajında yerel ve ulusal elektrik kodlarına uyulması gerekir.

## 15. Montaj Kodları



Bu cihazın, ülke ulusal elektrik kodlarının son sürümüne göre monte edilmesi gerekir. Kuzey Amerika için, ekipmanın ABD Ulusal Elektrik Kodu ve Kanada Elektrik Kodu'nun uygulama koşullarına göre monte edilmesi gerekir.

## 16. UL Kayıtlı ve CSA Onaylı Güç Kaynağı Kablosu



Kuzey Amerika'da güç bağlantısı için, UL Kayıtlı ve CSA Onaylı bir güç kaynağı kablosu seçin, 3 - iletken, [16 AWG], 125 V değerinde, kalıplanmış bir fişle biten, [13 A], en az 1,5 m (altı fit) uzunluğunda fakat 4,5 m'den uzun olmayan bir kablo. Avrupa'da güç bağlantısı için, uluslararası uyumlu ve “<HAR>” işaretli, 3 - iletken, en az 1,0 mm<sup>2</sup> tel, 300 V değerinde ve PVC yalıtımlı bir güç kaynağı kablosu seçin. Kablonun 250 V, 10 A değerinde bir kalıplanmış fişi olması gerekmektedir.

## 17. Yüksek Kaçak Akım



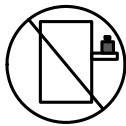
**Uyarı:** Yüksek kaçak akım varsa; güç kaynağına bağlanmadan önce mutlaka topraklama bağlantısı yapılmalıdır.

## 18. Ünitelerin Ara Bağlantısı



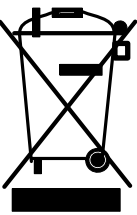
RS232 ünitesini ve Ethernet Arabirimlerini bağlayacak olan kabloların UL onaylı DP-1 veya DP-2 tipi olması gerekir. (Not- LPS olmayan devreye aitse) Aşırı Akım Koruması: Kolayca erişilebilecek 20 V Kayıtlı devre parçası aşırı akım koruma cihazının bina elektrik şebekesinde kurulu olması gerekir.

## 19. Anahtar Raf veya Çalışma Alanı olarak kullanmayın!



**Dikkat:** Sürgülü/raylı ekipman raf veya çalışma alanı olarak kullanılamaz. Raylar üniteyi iskeleden uzağa kaydırmak için yapılmamıştır. Sadece, ekipmanın son olarak duracağı yerdeki kalıcı montaj içindir, servis veya bakım için kullanılamaz.

## 20. WEEE Yönergesi



WEEE Yönergesi 2002/96/EC uyarınca, tüm elektrikli ve elektronik ekipman atıkları (EEE) ayrı olarak toplanmalı ve evsel atıklarla birlikte çöpe atılmamalıdır. Bu ürün ve tüm parçaları çevreye dost ve sorumlu bir şekilde imha edilmelidir.

## 21. Norveç Güç Kısıtlamaları



Bu ünite, bir TN güç sistemine ve sadece Norveç'in IT güç sistemine bağlanmak içindir.

## G.13 Japan VCCI Class A Statement

この装置は、クラス A 情報技術装置です。この装置を家庭環境で使用すると電波妨害を引き起こすことがあります。この場合には使用者が適切な対策を講ずるよう要求されることがあります。 VCCI-A