

The author/s of this paper did not submit it to AES HQ before the convention at which it was presented in time for it receive an AES preprint/paper number. Therefore, it is listed in the convention program as "No Preprint Available."

The author/s have subsequently submitted the following pages for documentation of the presentation at the convention for inclusion in the AES E-Library.

PARAMETRIC EQUALIZATION

by
George Massenburg
ITI Audio Products/ITIRI Studios
Hunt Valley, Md.

PRESENTED AT THE
42nd CONVENTION
MAY 2-5, 1972



AN AUDIO ENGINEERING SOCIETY PREPRINT

Convention Price\$.35
By Mail to Members\$.75
By Mail to Non-Members...\$1.00

This preprint has been reproduced from the author's advance manuscript, without editing or corrections. For this reason there may be changes should this paper be published in the Audio Engineering Society Journal.

Additional preprints may be obtained by sending request and remittance to the Audio Engineering Society Room 428, 60 East 42nd Street, New York, N. Y. 10017.

PARAMETRIC EQUALIZATION

by
George Massenburg
ITI Audio Products/ITIRI Studios
Cockeysville, Maryland

This presentation concerns the application of new equalization techniques to professional audio control. The device utilized is a parametric equalizer which: 1) offers vernier control of frequency and amplitude, and coherent control of "Q" or shape, 2) is suitable for automatic voltage control, and 3) improves transient and phase response by the use of all-active RC circuitry which also eliminates parasitics.

The equalizer is a general device applied in many different forms throughout signal processing. In most cases, equalizers correct for predictable variations in signal amplitude with respect to frequency. In other cases they provide complementary response characteristics to optimize operating conditions within such processes as tape and disc recording as a subjective art rather than an archival, or simple communicative, process the use of active, variable equalization as an additional control of subjective sound quality has expanded. The variable equalizer as a processing tool is the subject of this dissertation.

Most console and program equalizers derive their operation from the same basic circuit, and the tones perceived in their operation depend, for the most part, on different, chosen electrical parameters in similar configurations. Three general characteristics determine the effect of, and hence the sound of, the individual peaking or dipping section. These are center frequency, "Q" or peak shape, and peak amplitude above a given reference.

After criteria of price and panel finish, most equalizers are chosen by ear and reputation. And, although the average popular musical group is measured less stringently, a simple criterium for equalizers is usually avoided. All other things being equal (and the circuits certainly are), some engineers will choose equalization which renders the highest peak amplitude. How, an engineer may never use a 24 dB peak but, like the plethora of patch points in most studios, it's comforting to many to have it available if it's needed. The truth is that higher reliability and more flexible switching will replace, to an extent, the unreliable patchbay; and more accurate and flexible simulation of the equalization peak will be the dominant pursuit in equalization. Many recent designs attest to this and have included ever more switch selectable frequencies. The selection of characteristics in an equalizer is then a subtle balance of many factors including sound itself.

An acoustic source in a reverberant field is, by its very nature, complex and unpredictable. Attempts at correction with one simple peak are incongruent with a source which contains many anomalies close together. To correct for this, graphic equalizers have been expanded to more bands, closer together. Now, the graphic equalizer as we used to know it was, and still is, a cumbersome device effecting independent control of the amplitude of a number of bands of set frequency.

The larger the number of bands, the greater the number of controls, the smaller the width of the individual peak, and the greater control over the more subtle anomaly; all of these vary together. Many commercial units are flexible to the detriment of operational practicality. The more bands to set, the longer the set-up time, and the larger the units are. The large ones won't fit in each mix position of the console and are prohibitively expensive. Smaller modular graphics have recently been designed with fewer bands; however, they seem to be as complex and slow in operation as any other graphic.

A BRIEF HISTORY

Figures 1A-1E show the classical forms of simple reactive and resonant circuits which combine to yield low and high frequency shelves and droops and a peak which, with adjustment of L & C, could occur at any frequency. To simplify matters for commercial and home entertainment industries, a simple circuit (the Baxendall) with less pots was developed - the circuit yielded a bizarre but sufficient low and high frequency equalization. The most popular program equalizers combined Figures 1A-1E. All of these circuits required gain to restore inherent losses and margin. Some could not provide one-knob control of a particular function without switching (the L-C sections were usually controlled by a stepped switch to provide incremental level change and inversion of the circuit to change from attenuation to equalization, as in the Cinema unit). Other equalizers, like the Lang, provided separate controls for each function. All units changed peak frequency by switching L-C values. Almost every equalizer built before 1965 was a permutation of these circuits. Whether they had gain inserted thereafter, or were a part of a feedback function, it was the same basic design.

With the advent of comparatively inexpensive hybrid and integrated circuits came consoles with new equalizer format, as in the Data-Mix or the Electrodyne consoles of several years ago. While overall performance suffered from disparaging operation with a new and undebugged technology, the format was an improvement, and the equalizer had evolved to take full advantage of the flexibility of operational amplifiers. A general schematic is shown in Figure 2A. Inherently flexible, lossless, and containing fewer components, the circuit is adaptable to automatic supervision of levels (the attenuator is a simple pot or ladder for the full range from peak to dip), but still requires switch closers and more components to provide the selection of equalization frequencies. And the simplest circuit still must contain inductors for peaks and for low frequency shelves. Most commercial devices of this form have several frequencies in each of two or more ranges. A graphic equalizer can easily be assembled in this configuration as shown in Figure 2B. Assuredly, almost every new equalizer resemble to above two.

CRITERIA FOR A STATE-OF-THE-ART EQUALIZER

The Parametric Equalizer evolved from an open set of non-ducible standards. As far back as the early sixties, when multi-track as we know it today was coming into its own, it was

relatively obvious that the environs of recording could benefit from the advantages of automation - organizing and memorizing routine and repetitive operations. Thus a new measure of designs of all devices became their compatibility with basic computational and memory systems. The time is, hopefully, not far away when we will concern ourselves with handling audio as a digital code - that is, converting all audio input to digital words for all processing and mixing and converting back thereafter only at the point of listening. The equalizer and switching projects simply modified these circuit functions to interface with digital systems.

The thrust of the project became threefold. First automation: to reduce many switchable functions to functions which could be controlled by either a variable resistor (or FET ladder) or a variable gain stage. Second, how to eliminate the inductor? Now, the iron core inductor, permutations therefrom, and applications are legend. But the crude and marginally sufficient performance of popular inductors is becoming ever more unsuitable in compact, modern, high-performance systems. Transformers are disappearing, the electret condenser microphone is much cheaper than comparable dynamics, even loudspeakers as we know them today could be replaced by molecular pump loudspeakers. Third, to produce an equalizer of unparalleled flexibility - one that would provide the audio engineer with absolute control over all variable EQ functions. Thus, we have dispensed with the inductor and the variable inductor in the basic resonant section, and dispensed with transformers for coupling; and present three high performance replacements.

The resultant performance from the equalizer was encouraging enough to persuade us to release the device independently.

THE PARAMETRIC EQUALIZER

Our final specifications were stringent indeed. The device had to be adaptable to automatic control with the most simple interface. The frequency should be continuously variable, as should the peak and dip amplitude, and the peak shape. The unit should be small enough for a module in an average console, without sacrificing operational performance - the controls should be uncrowded and operationally useful. The three bands of 12 dB equalization should overlap substantially and extend from below 20 Hz to above 20kHz. And, aside from this, the electrical specifications (dynamic range, noise, frequency response, etc.) must meet or exceed state-of-the-art values. We were also looking for much better phase response, and greatly reduced parasitics - this effectively eliminated inductors and transformers.

There are several choices for replacement of the inductor in a resonant circuit. The most direct analog is the gyrator as shown in Figure 3. The gyrator is a three-port device which exhibits a negative impedance characteristic between the input and output. Let it suffice to say that if one side of the circuit looks into a capacitor, the other side looks like an inductor. The stray capacitances, hence parasitic oscillation, are much lower; hum pick-up is much less (without shielding) and a better inductor results. Optimizing the circuit is tricky, and it can cost more than an inductor; we offer the device as an option in the low frequency shelving circuit only.

The choice of replacement in the peaking system is a variation on the T-notch filter. By adjusting R , C_1 , C_2 as shown in Figure 4, a broad range of notch shapes and frequencies may be achieved. And by changing the value of R , such that the two R 's track tightly, the frequency may

be swept. The notch shape is chosen to be quite broad - that is, C_1 much larger than C_2 - and each band's peak shape can be varied over a wide scale of values by operating at different point on the basic curve as shown in Figure 5. Once the peak shape and its lowest frequency are chosen for a given R, the notch frequency increases as the reciprocal of decreasing R. With the notch around an amp as shown in Figure 6, a peak results. A control is added in the feedback of this amp to adjust peak height and input level simultaneously; this adjusts the desired peak shape. An added advantage of varying the shape in the manner is that the processed peak height remains constant with rotation of the shape control, while only the skirts change as shown in Figure 7.

What we have now is a three-port device (an L-C-R is a two-port), and it cannot operate in the manner shown in Figure 2. Therefore, the resultant operator, containing variable notch, notch inverter, and shape control, is connected as shown in Figure 8. The operation of the level control is such that the input of the processor is moved between the system input the the system output. The equalizer will move from a peak to its perfect reciprocal with rotation of this control. Since this function is not within the resonant circuit, the "Q" does not change with rotation of the level control, as it does in conventional equalizers (Figure 9).

The final circuit is shown in Figure 10, and is as described with the addition of a shelver to augment the device as a program equalizer. The circuit produces two low frequency shelves and a high frequency shelf, all reciprocally as shown in Figure 11, in addition to the three Parametric Equalization sections. Also, we add an active transformer on the input and output. These amps are the same once we build for low-gain applications in other places in the equalizer and in our consoles. The amps have much lower phase shift and distortion, and high power response versus package size. They behave like transformers in that they have high common-mode rejection, and will tolerate a short in one side of a balanced circuit without changing level or wasting power.

BLUE SKIES DEPARTMENT

The device is automated by replacing the pots with FET ladders driven by a six level BCD code with address. The simple form of the FET ladder is shown in Figure 12. The least significant bit causes a resistance variation of one in sixty-four; the most significant bit, a variation of thirty-two parts in sixty-four; which, although not a continuous scale, comes very close. The pots which once directly controlled the three functions revert to a central clocked A to D converter and are addressed sequentially. When the method of storage, whether it be static as in punched tape or mass magnetic memory, or dynamic memory on the master tape itself - is not to be utilized, the information from the individual pot is simply recycled back to its respective function. The foremost advantage of the system is the rather uncomplicated decoding; the FET ladder is inherently compatible with BCD input, and requires no individual D to A converters, Sample and Hold gates, and reduces the complexity of the control signal-to-resistance interface.

ANALYSIS

The Parametric Equalizer is an appropriate compromise between a three-knob switched frequency equalizer, a graphic equalizer, and a program equalizer; and adds the capability for automation. The equalizer can produce a very sharp notch, like a graphic, and hold the shape over various depths to remove, say, the low frequency resonance in an acoustic guitar being picked up by a cardioid microphone. In its broadest position the equalizer looks broader than most broad peaks in peaking equalizers. It can produce a peak at any frequency and shape and

contour its effect to match an anomaly to be removed. Although a three-band model cannot construct as complex a characteristic as a graphic, its variable shape and frequency let it come closer to an average correction than a typical equalizer. And it is much faster than a graphic in that one can hear the peak being swept through the point of correction, and one can accurately and quickly judge the frequency and amount of correction needed. its curves are broad enough so that the mid-section can apply to broad boost to the upper mid-range, while the high frequency section can apply a sharp dip to remove vocal sibilances concentrated around one frequency. The unit can simulate perspective effects, like loudness contours, accurately. Finally, the Parametric Equalizer can provide a number of special effects by sweeping frequency.

As equalizer performance requirement have become more stringent, new signal processing techniques have become necessary. The development of Parametric Equalization is the first step in providing the audio engineer with complete control of spectrum modification while providing a foundation for future automation.

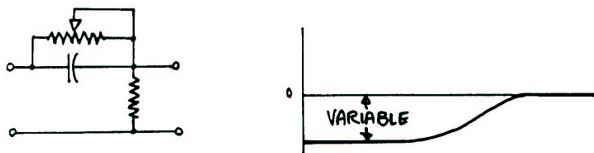

FIG 1B - VARIABLE LOW FREQUENCY DROOP

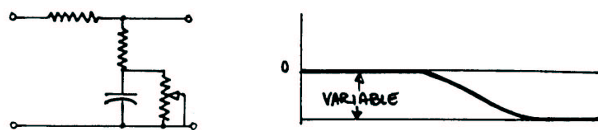

FIG 1A - VARIABLE LOW FREQUENCY SHELF

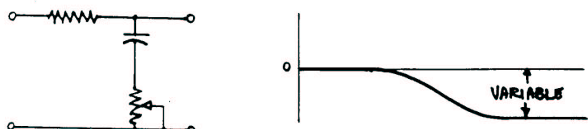

FIG 1D - VARIABLE HIGH FREQUENCY DROOP

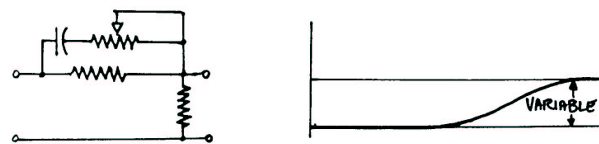

FIG 1C - VARIABLE HIGH FREQUENCY SHELF

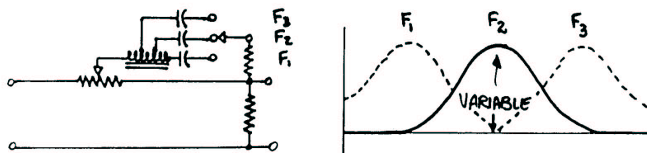

FIG 1E - VARIABLE FREQUENCY PEAK

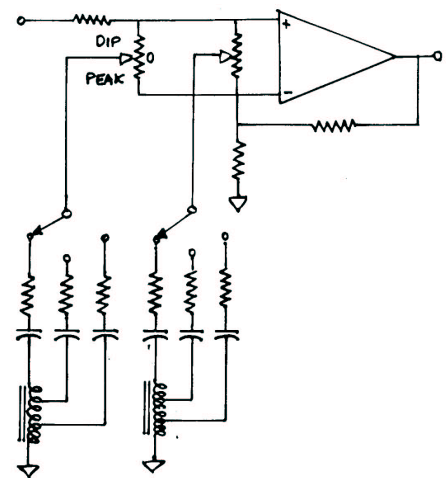

FIG 2A - FEEDBACK L-C EQUALIZER (Peak and Dip)

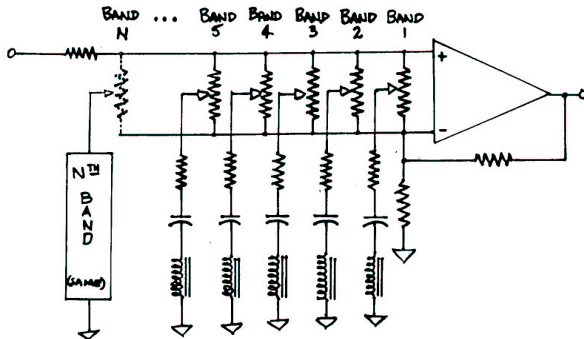

FIG 2B - FEEDBACK L-C GRAPHIC EQUALIZER (Multiple Peak)

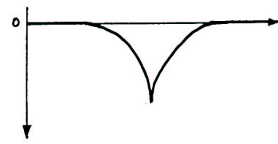
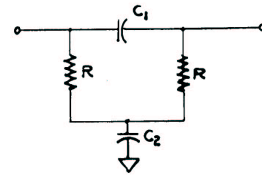

FIG 4 - BASIC NOTCH

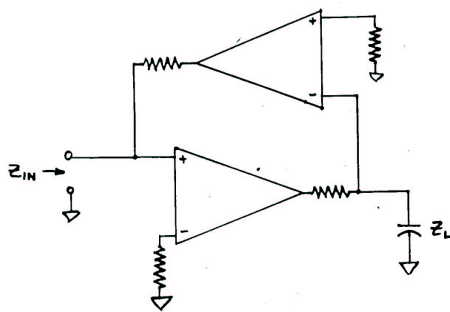

FIG 3 - SIMPLE GYRATOR

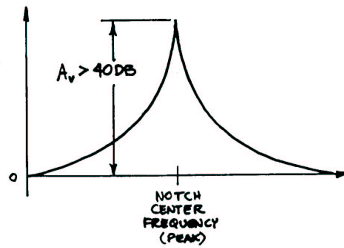

FIG 5 - INVERTED NOTCH before shape processing.
Note wide range (more than 40db).

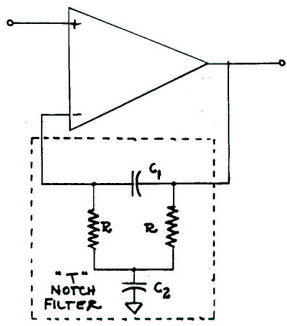

FIG 6 - PEAK INVERSION

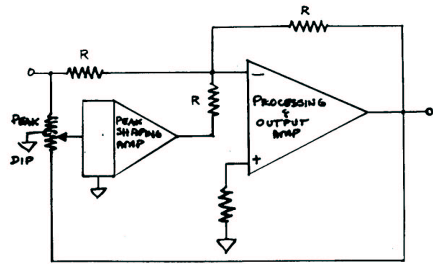

FIG 8 - BASIC PARAMETRIC SECTION

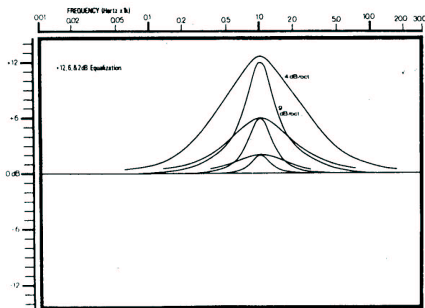

FIG 7 - PEAK "Q" versus rotation of AMPLITUDE

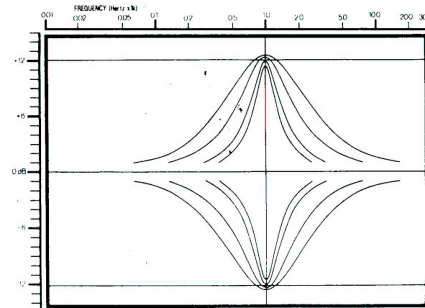

FIG 9 - "Q" versus rotation of SHAPE

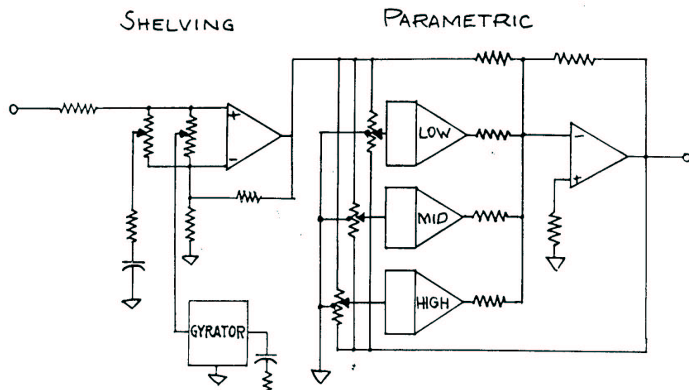

FIG 10 - FULL SYSTEM with three parametric peaks and two shelves

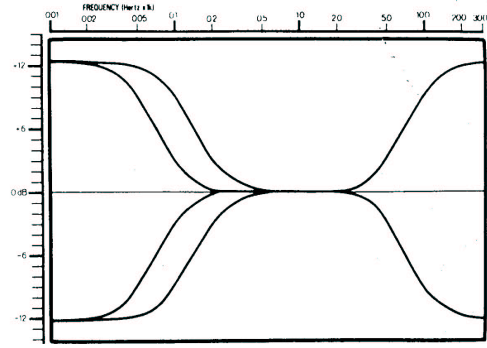

FIG 11 - SHELVING CURVES

