

International Overview Training: Post-2017 Tax Reform



Topic IV Global Tax Org Chart – Post Tax Cuts and Jobs Act of 2017



Large Business
& International

IRS Front Matter Items

- The IRS Mission Statement
- 14 General Principles of Ethical Conduct for Federal Employees
- Your Rights as a Taxpayer

Overview

- Global Tax Organizational Charts (GTOCs) provide key information to issue teams about a company's tax planning strategies
 - Understanding a taxpayer's tax planning objectives is key in issue identification
- GTOCs use standard symbols in industry to represent different types of entities for US tax filing purposes
 - Review of taxpayer's GTOC structure provides valuable exam risk information (i.e., what US compliance is required and what types of global tax structures are in place)

Overview (Cont'd)

- Transactional flow analysis using a company's step plan org charts may assist in exam risk identification
 - Details matter – transactional analysis of step plans provides key insight into taxpayer's filing position regarding an acquisition, disposition or restructuring transaction

Learning Objectives

At the end of this lesson you will be able to:

- A. Identify taxpayer's objectives in global tax planning
- B. Interpret a taxpayer's GTOC
- C. Use GTOCs to identify taxpayer's planning objectives



A. Taxpayer's Objectives in Global Tax Planning



**Large Business
& International**

Basics of Strategic Global Tax Planning

- In conducting and structuring business operations, a Multinational Enterprise (MNE) may consider its strategic global tax plan.
- A company's strategic global tax plan could strive to:
 - Increase Earnings Per Share (EPS)
 - Minimize Effective Tax Rate (ETR)
 - Manage cash and expenses
 - Manage tax risks

Basics of Strategic Global Tax Planning (Cont'd)

- Sustained, predictable improvements in EPS
 - Increase share price and total market capitalization
 - Possibly boost executive compensation when tied to EPS

- Reduce Tax Expense
 - Tax expense directly reduces net income, which unfavorably lowers EPS

- Control Costs
 - Companies try to manage costs efficiently (including taxes) to produce shareholder value
 - Tax costs can be managed efficiently through permissible planning

How Do Taxpayers Achieve Global Tax Planning Objectives?

- Reduce ETR, for example, by:
 - Generating income in offshore low tax jurisdictions
 - Reducing net income by borrowing and other strategies
 - Minimizing exposure to IRC 163(j), 267A, Global Intangible Low-Taxed Income (GILTI) and Base Erosion Anti-Abuse Tax (BEAT)
 - Maximizing income taxed as Foreign Derived Intangible Income (FDII)
 - Maximizing income subject to the participation exemption
 - Minimizing US and foreign income taxes
 - Utilizing past and current foreign losses for tax benefit
 - Because certain foreign earnings when repatriated no longer bring FTCs, US MNEs may affirmatively plan into Subpart-F for high tax CFCs, which would bring back FTCs.

How Do Taxpayers Achieve Global Tax Planning Objectives? (Cont'd)

- Manage tax risks within global tax strategy
 - Strategic planning that is integrated into the business strategy
 - Minimization of tax and treasury risks
 - Shift tax risk to lower tax jurisdictions
 - Tax risk may come from a variety of sources including business model, transaction flows, tax law changes, tax planning, execution and maintenance of transactions, people, etc.
 - Shifting intangible property and related income to lower tax jurisdictions, while avoiding 367(d) exposure

IRS Objective: Understanding US MNE's Tax Planning Strategies

- Pre-TCJA in absence of Indefinite Reinvestment Assertion (IRA):
 - Securities and Exchange Commission (SEC) reporting companies would need to estimate how much of their foreign earnings would eventually be repatriated
 - A tax accrual was made for earnings which were designated to be repatriated in the future
 - This tax expense increased ETR

IRS Objective: Understanding US MNE's Tax Planning Strategies (Cont'd)

- In general, prior to TCJA, foreign subsidiaries were presumed to repatriate all earnings to USP for US GAAP purposes. The future tax on such earnings was included for book purposes even though not yet subject to tax. However, an MNE could make the indefinite reinvestment assertion (IRA)* that its earnings were indefinitely reinvested if USP had specific plans for reinvestment of those earnings. As such, an MNE could defer and plan when GAAP financial statements included the tax liability on foreign subsidiary earnings.
- As noted in Topic III, post-TCJA, MNEs will still assert IRA or it may be required to report certain tax expenses in its US GAAP financial statements that otherwise would be deferred (e.g., deferred tax liability for foreign withholding taxes, deferred taxes on foreign currency movements related to withholding tax liability and deferral of foreign earnings for state tax purposes.)



IRS Objective: Understanding US MNE's Tax Planning Strategies (Cont'd)

- Reviewing the GTOC will help issue teams understand taxpayer tax planning goals and identify potential issues
- Keep in mind, a low ETR can be due to legitimate tax planning

IRS Objective: Understanding US MNE's Tax Planning Strategies (Cont'd)

It is important to note:

- The bottom-line questions for issue identification in the international area are:
 - Are beneficial tax attributes being generated?
 - Which entities are generating the beneficial tax attributes?
 - How are the beneficial tax attributes generated?
 - Where are the beneficial tax attributes being utilized?
 - When evaluating Income Shifting issues: who bears the risks generating the tax attributes?
- A low ETR does not indicate abuse but may suggest further inquiry is required

How Can GTOC Analysis Help?

- Many LB&I MNE cases are complex and fact intensive
- Comparing taxpayer provided Beginning of Year (BOY) and End of Year (EOY) GTOCs will assist in identifying organizational changes for the year under exam
- For issue clarification, creating org charts, transactional flow charts, and formal written narratives will help you:
 - Organize your thoughts
 - Identify unknown but needed facts
 - Ask pertinent questions
 - See the big picture

How Can GTOC Analysis Help? (Cont'd)

- Use organizational charts, transactional flow charts, and written narratives to communicate the facts of your case
- These tools assist you in communicating with:
 - Managers
 - Subject Matter Experts
 - Counsel
 - Specialists
 - Taxpayers and Representatives

How Can GTOC Analysis Help? (Cont'd)

- Your documented analysis will:
 - Demonstrate your knowledge of the case
 - Create a record of your work on the case
 - Support your conclusions
 - Serve as the basis for obtaining agreement or for sending a well-developed factual case to Appeals
 - Assist in understanding how a tax exam adjustment will impact taxpayer's ETR

How Can GTOC Analysis Help? (Cont'd)

Proper labeling is important!

- Distinguish the type of entity (e.g., Controlled Foreign Corporation (CFC), Check The Box (CTB), Disregarded Entity (DE), Foreign Disregarded Entity (FDE), Controlled Foreign Partnership (CFP), etc.)
 - DEs and FDEs, are “disregarded” from their owner for US income tax purposes but are “regarded” for legal purposes. (e.g., single member Limited Liability Company (LLC), Disregarded Entity which Checked-the-Box, etc.)
- Show actual direct ownership
 - It is important to include each entity in the diagram, showing the actual ownership structure to fully understand the structure and identify potential issues

How Can GTOC Analysis Help? (Cont'd)

Proper labeling is important! (Cont'd)

- Determine jurisdiction/country
 - It is important to properly diagram and label the entities so that the reader can determine jurisdiction of income tax liability and to determine jurisdiction for sourcing of income
 - Country of incorporation
 - Country of taxing jurisdiction
 - Source country of management and control
- Determine proper US entity classification
 - In order to determine the proper US income tax results, it is often helpful to explain the US entity classification and the associated US income tax treatment of the transaction on the diagram



B. Interpreting GTOCs



**Large Business
& International**

Distinguish GTOCs From Other Types of Org Charts

- Taxpayers may use several different organization charts within their accounting and tax operations:
 - Tax Compliance Org Charts
 - Corporate Secretary/Legal Entity Charts
 - Enterprise General Ledger System Org Charts
 - Transactional Flow Charts (Transactional Step Plans)
- Beware - these charts are not tax org charts and do not necessarily indicate all legal entities and their U.S. tax classification.

Distinguish GTOCs From Other Types of Org Charts (Cont'd)

- Corporate Secretary (Legal Entity) Charts
 - Most large taxpayer Corporate Secretaries use specific function legal entity software applications for managing and recording legal ownership of entities
 - Most often the application is used for state/municipality licensing and franchise reports requirements
 - Although, the resulting org charts may indicate “by legal entity,” they are not reliable for representing US entity classification for tax compliance purposes. However, these charts can provide factual information about legal reasons for entity choice that could, in turn, provide the issue team with valuable information.

Distinguish GTOCs From Other Types of Org Charts (Cont'd)

- Enterprise General Ledger System Org Charts
 - Most Accounting Departments use specific function general ledger software applications for accounting and reporting purposes.
 - These applications have functionality to create organizational charts based on legal entity, business unit, branches, etc. to accommodate financial reporting purposes.
 - Although, the resulting org charts may be listed somewhat by legal entity, they are not reliable for representing all entities' tax reporting status for US tax reporting purposes.
 - Issue teams need to understand the system to be able to bridge the financial data to the tax return.

Distinguish GTOCs From Other Types of Org Charts (Cont'd)

Global Tax Org Charts

- A tax organization chart refers to a legal organization chart which has been modified to depict:
 - The US tax classification of various legal entities and persons,
 - The direct ownership of each entity, **and**
 - The entity's country of incorporation

- Each type of entity or person is illustrated by a unique symbol.
 - Understanding these symbols and the associated US tax consequences is critical to the reading of a GTOC

Distinguish GTOCs From Other Types of Org Charts (Cont'd)

Global Tax Org Charts (Cont'd)

- Large Taxpayers use Enterprise Tax Compliance software or other function specific software to create GTOCs for US classification and reporting purposes.
- Other Taxpayers may prepare in-house tax compliance org charts using some other software application.
- It is important that the issue team is clear about the source and accuracy of the tax compliance or transactional org chart received from the taxpayer.
 - That is, ensure that all entities are correctly represented in the chart including DEs and other flow-throughs.

Distinguish GTOCs From Other Types of Org Charts (Cont'd)

- Information Document Requests (IDRs) should request the taxpayer's GTOC to get the best representation of the taxpayer's US reporting obligations
- If no tax compliance (GTOC) or transactional chart (i.e. step plan) is available:
 - Create a chart to document your understanding of the issue under review.
 - Use standard symbols provided in next section and as depicted on the LB&I Knowledge Based SharePoint site.
 - Submit chart to taxpayer to verify

Commonly Understood Symbols

- Each type of entity or person is illustrated by a unique symbol
- The ultimate parent is the entity at the top of the organization chart
 - This entity may or may not be the taxpayer
- Generally, each level of ownership down from the ultimate parent is referred to as a tier
 - For example, an entity owned by the ultimate parent is a 1st tier entity
- Vertical relationships are typically referred to as Parent-Subsidiary
- Horizontal relationships are typically referred to as Brother-Sister

Commonly Understood Symbols (Cont'd)

- The accounting community uses commonly-accepted symbols for use in creation of GTOCs.
- *Internally*, the IRS has expanded and standardized these symbols and colors for IRS-generated GTOCs.
 - US entities or disregarded entities included in US tax reporting entities are “White.”
 - Foreign entities not included in US tax reporting entity consolidated return are “Blue.”
- The following slides illustrate these symbols.
- Note: taxpayer provided GTOCs may not be color coded and/or incorporate shading, or even use these commonly-accepted symbols

Commonly Understood Symbols (Cont'd)

Below are commonly used symbols for GTOCs that you may encounter outside of IRS:



Corporation

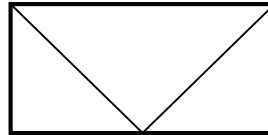

Reverse Hybrid Corporation
(US corporation, foreign pass-through)

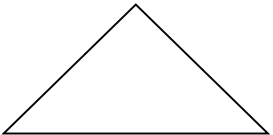

Partnership



Hybrid Partnership
(US pass-through, foreign corporation)

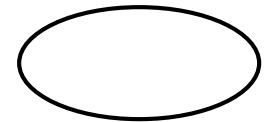

**Branch, DE or
Individual**

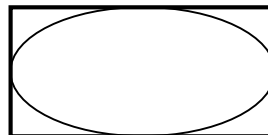

**Hybrid Branch or Disregarded Entity
"DE"**
(US branch or DE, foreign
corporation)

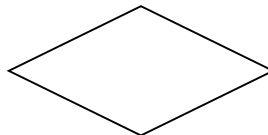

Trust

Commonly Understood Symbols (Cont'd)

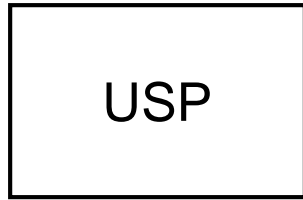

US parent corporation

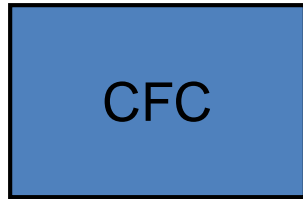

Controlled foreign corporation

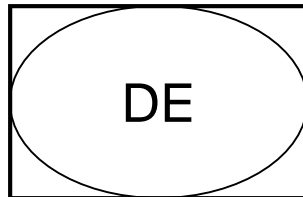

Disregarded entity that is owned directly by a US company – treated as a branch for US tax purposes; corporation in the country of organization

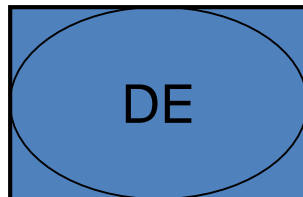

Disregarded entity for US tax purposes, corporation in the country of organization

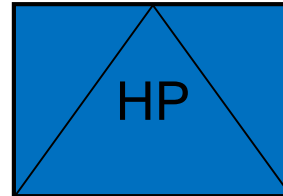

Hybrid partnership: Treated as a flow-through for US tax purposes; treated as a corporation in the country of organization

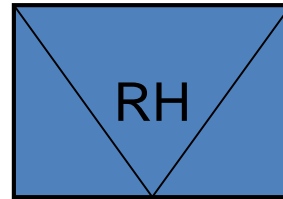

Reverse hybrid corporation – Treated as a corporation for US tax purposes; treated as a flow-through entity in the country of organization

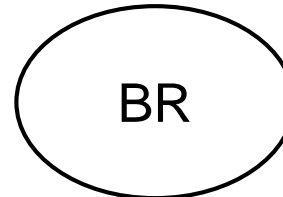

A true domestic branch (US and foreign tax purposes)

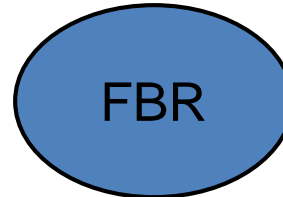

A true foreign branch (US and foreign tax purposes)

Commonly Understood Symbols (Cont'd)

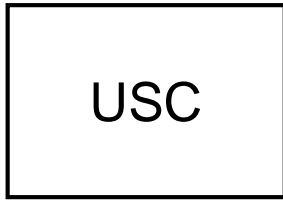

A US corporation or other domestic entity characterized as a corporate entity under the regulations (301.7701)



International business company formed in an offshore secrecy jurisdiction to disguise beneficial ownership of financial accounts, assets and investments

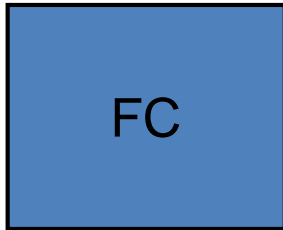

Foreign corporation



Bank located in an offshore secrecy jurisdiction that provides financial services for individual international clients

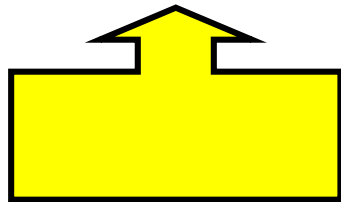

Withholding agent



Bank, investment, securities or other financial account

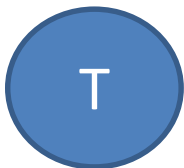

Treaty Implication

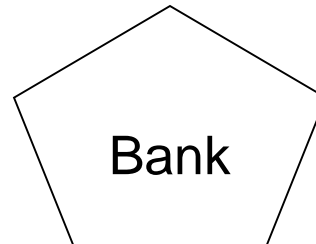

Bank

Commonly Understood Symbols (Cont'd)

For IRS training purposes, foreign entities are distinguished from US entities by shading their respective shapes. For example, the following Outbound and Inbound structures have the foreign entities shaded blue.

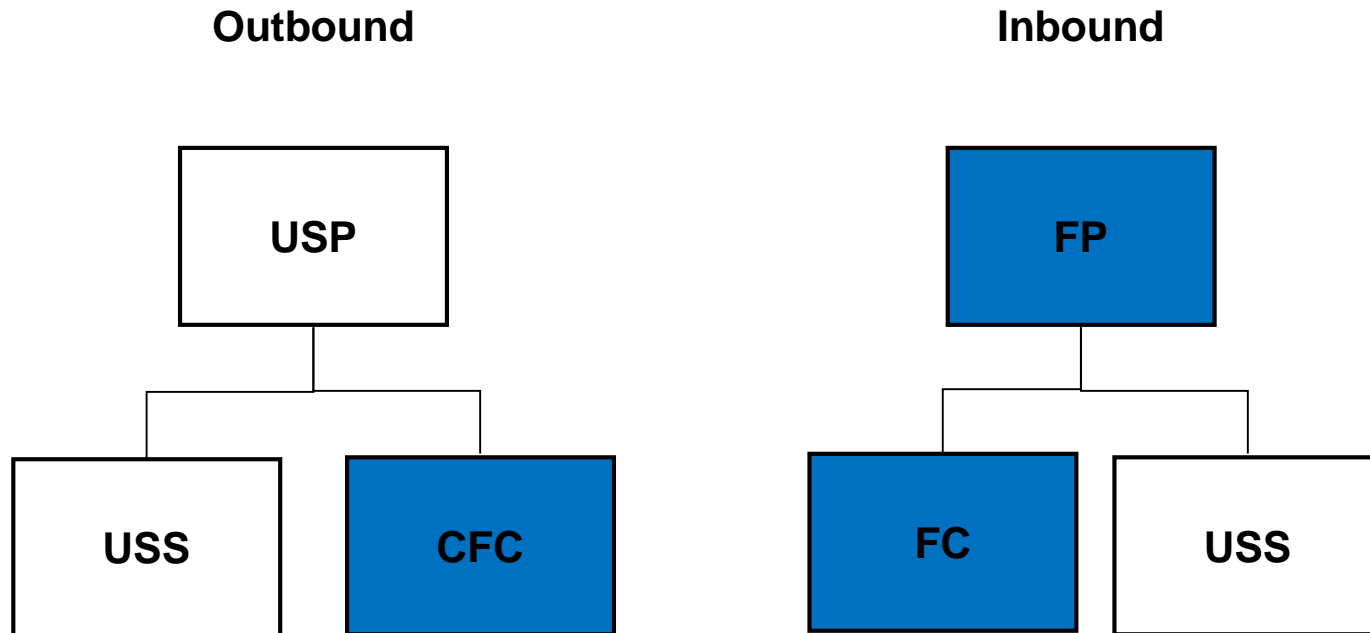

Interpreting a Basic GTOC

- **Outbound Structure:** US person is the ultimate parent of a foreign entity or conducts foreign activities through a branch. Some tax planning strategies available to outbound structures include:
 - Shift income or assets offshore
 - Manage foreign tax credits, and
 - Repatriate cash with little or no residual US tax cost

- **Inbound Structure:** Foreign person is the ultimate parent of a US entity or conducts US activities through a branch. Some tax planning strategies available to inbound structures include:
 - Minimize the US tax base
 - Shift US income-producing assets to low-tax jurisdictions

Compare BOY and EOY GTOC

- Why compare BOY and EOY GTOCs?
 - To identify any entity structure changes that may affect the tax attributes of the US filer for the current year and year to year changes

- Changes in entity structures may result from:
 - Acquisitions
 - Dispositions
 - Reorganizations
 - Change in tax entity structure for US purposes only (e.g., CTB election, F-Reorgs, conversion to LLC, etc.)
 - A CTB deemed liquidation of a CFC or other CTB actions can result in deemed restructurings without any foreign legal consequences.

Compare BOY and EOY GTOC (Cont'd)

- Once the entity structure changes are identified, analyze the changes to the US tax attributes of the reporting entity
- Examples of how the tax attributes may be affected:
 - Non-taxable income inclusions
 - Increase in FTC taken
 - Increase in Foreign Sourced Income (FSI), decrease in US sourced income
 - Increase in US sourced expenses
 - Income producing assets moved onshore or offshore
 - Character of income as eligible for deferral vs. subpart F or GILTI

GTOC Exercise (BOY)

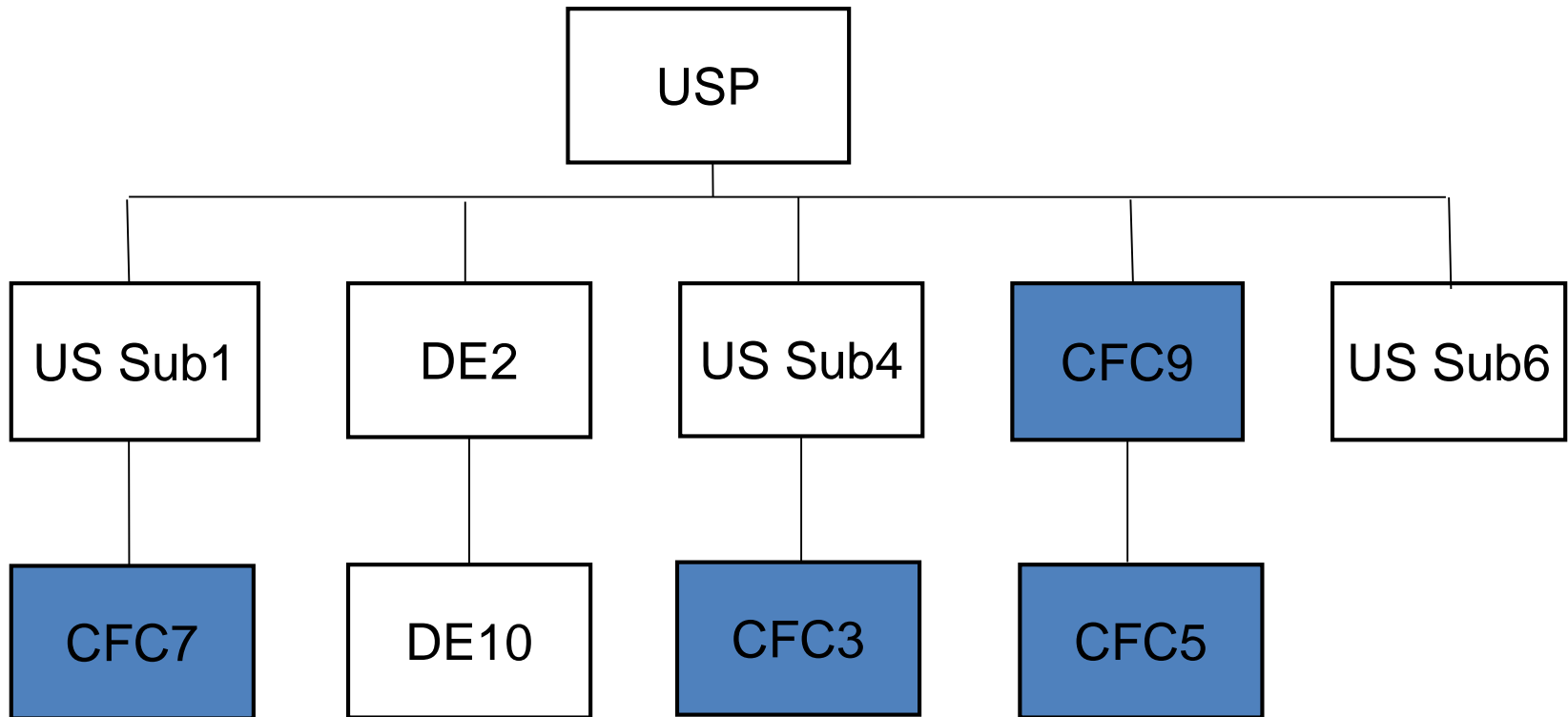

Corporation



Hybrid Entity - Disregarded Entity (DE) for US and Corporation for Foreign purposes

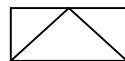

Hybrid Entity - Partnership for US and Corporation for Foreign purposes



GTOC Exercise (BOY) (Cont'd)

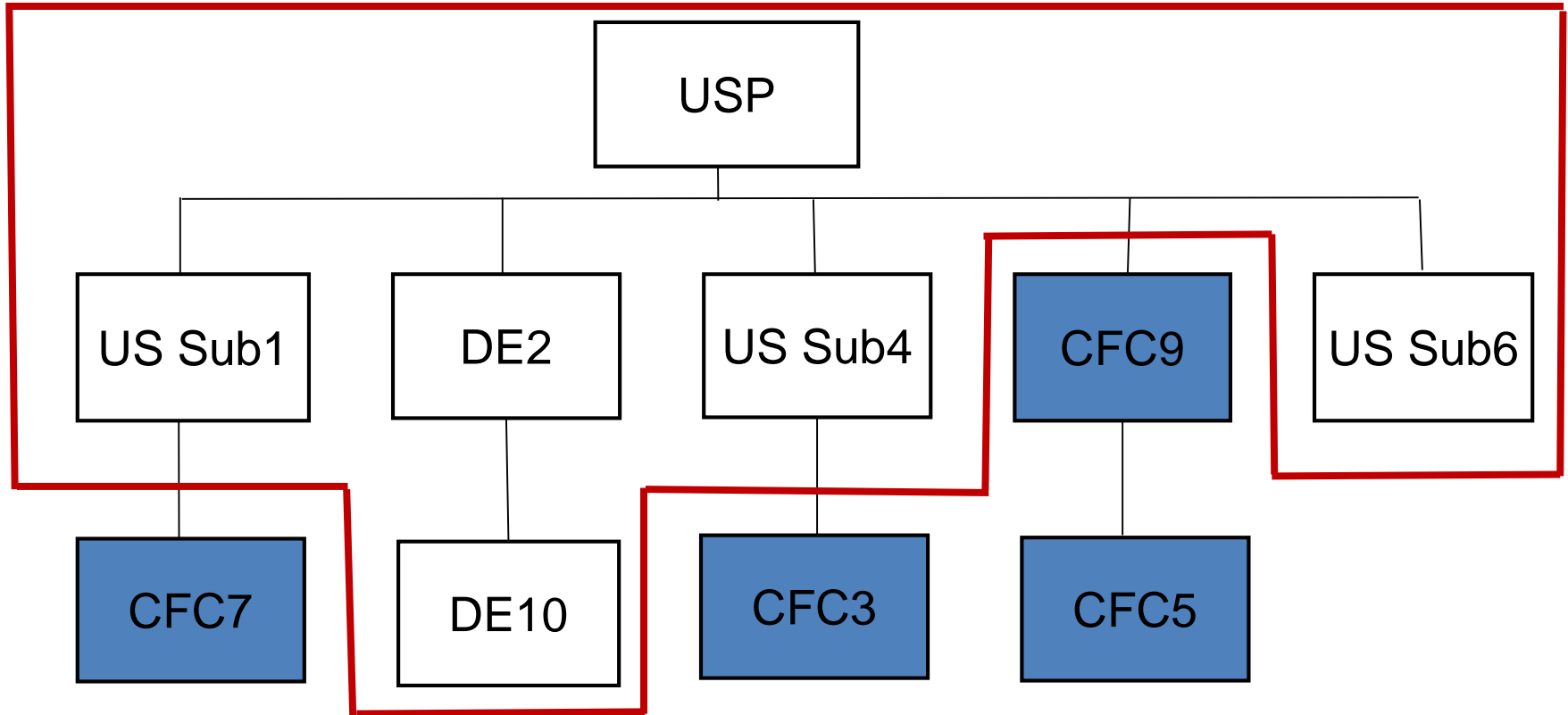

Corporation



Hybrid Entity - Disregarded Entity (DE) for US and Corporation for Foreign purposes



Hybrid Entity - Partnership for US and Corporation for Foreign purposes



Summary (BOY)

US Tax Group

- USP
- US Sub1
- US Sub4
- US Sub6
- DE2
- DE10

Offshore

- CFC7
- CFC3
- CFC5
- CFC9

GTOC Exercise (EOY)

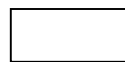
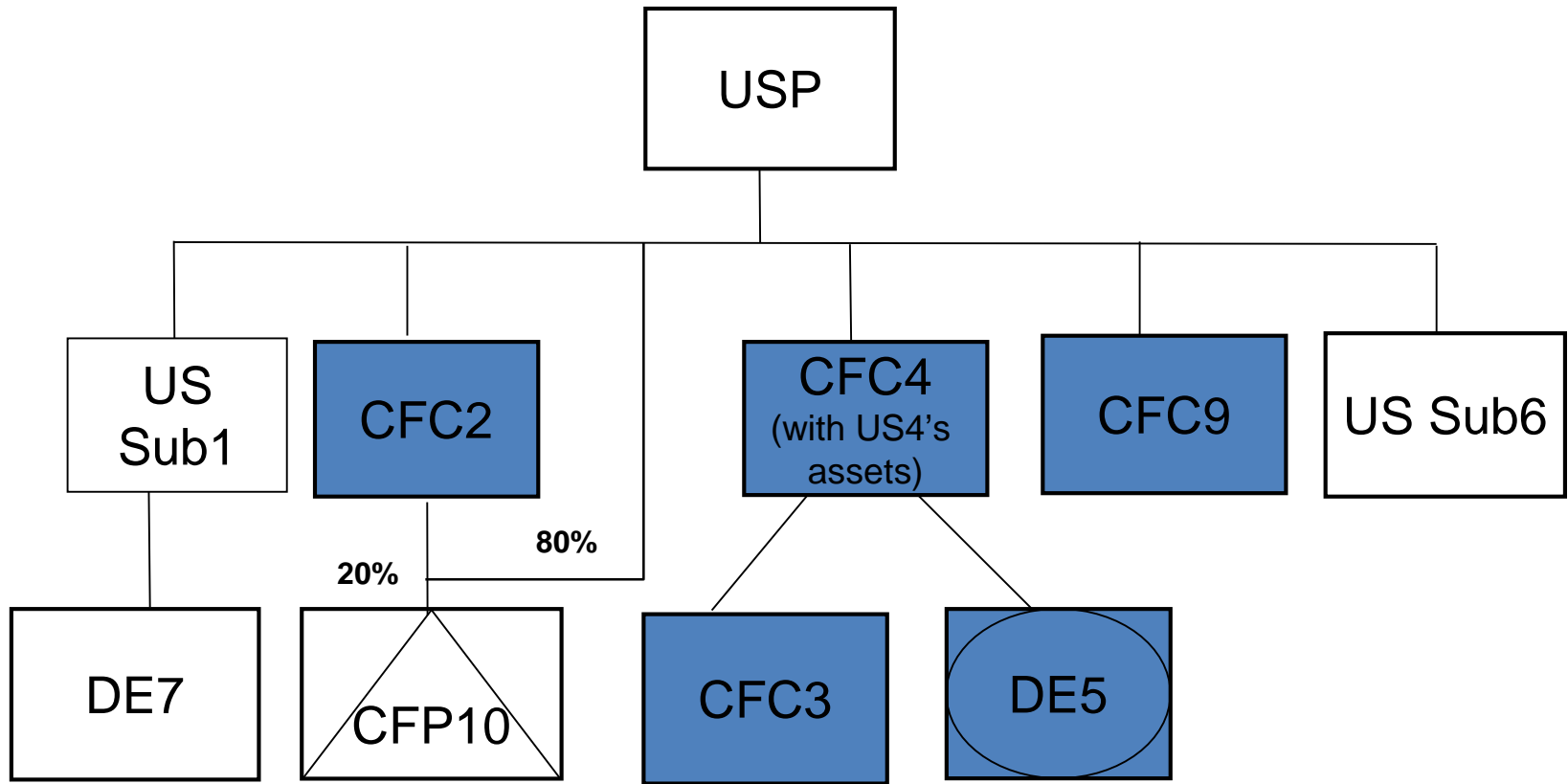

Corporation



Hybrid Entity - Disregarded Entity (DE) for US and Corporation for Foreign purposes



Hybrid Entity - Partnership for US and Corporation for Foreign purposes



GTOC Exercise (EOY) (Cont'd)

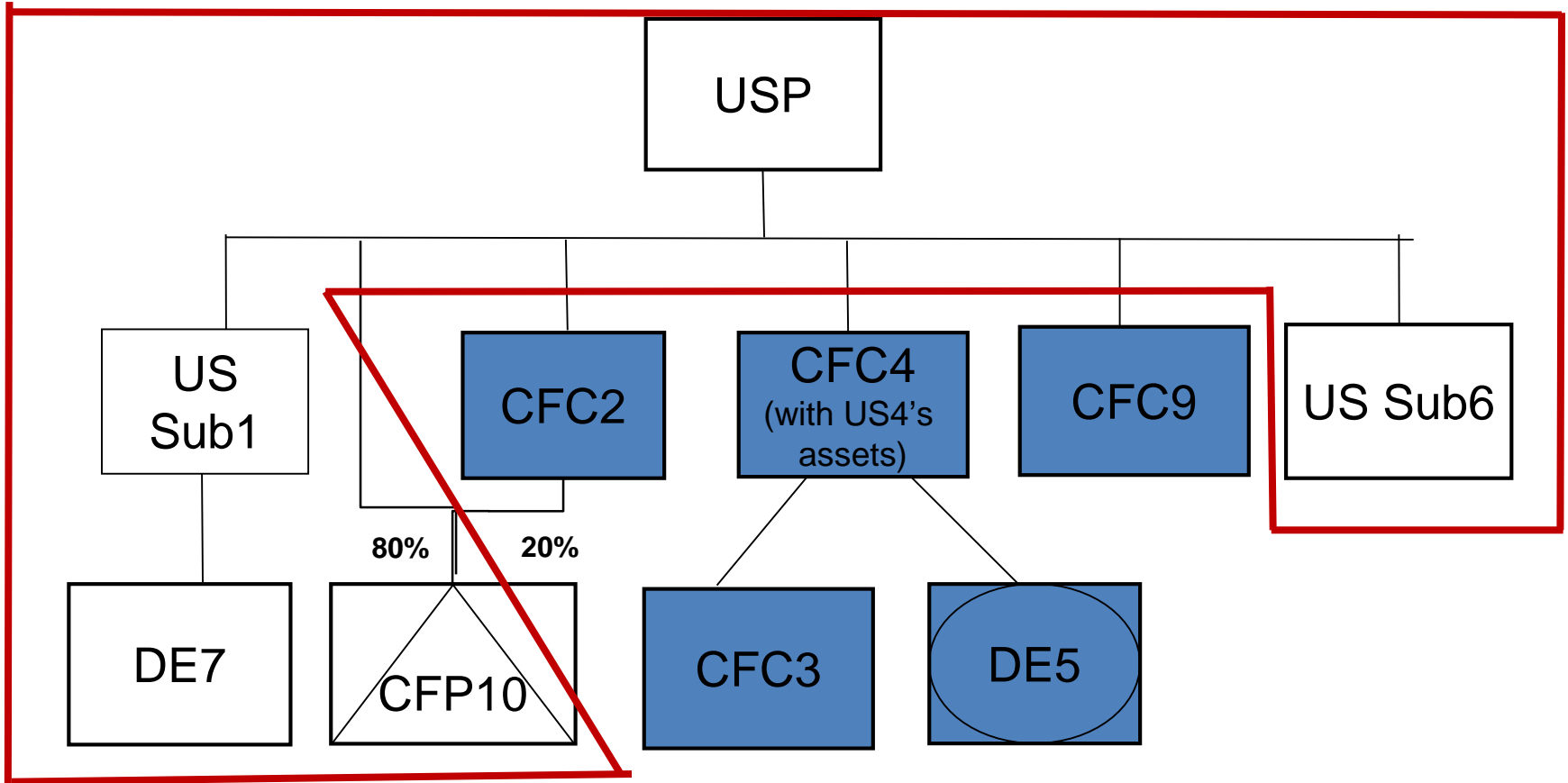

Corporation



Hybrid Entity - Disregarded Entity (DE) for US and Corporation for Foreign purposes

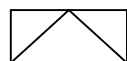

Hybrid Entity - Partnership for US and Corporation for Foreign purposes



Summary (EOY)

US Tax Group

- USP
- US Sub1
- DE7
- US Sub6
- 80% of CFP10

Offshore

- CFC2
- 20% of CFP10
- CFC4
- CFC3
- DE5
- CFC9

Possible Transactions

- **US Sub 1**

- No change in form

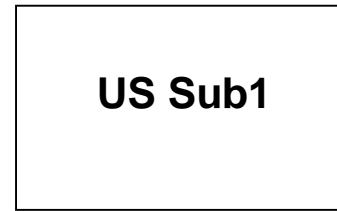

- **CFC7**

- Made an election to be disregarded
 - Filed Form 8832
 - Filed final Form 5471
 - Files initial Form 8858

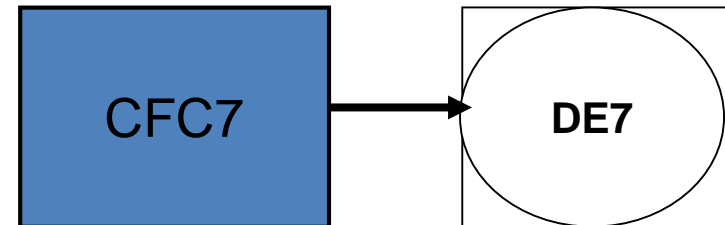

Possible Transactions (Cont'd)

■ DE2

- Made election to be regarded
- Outbound transfer of property (USP filed Form 926)
- Filed Form 8832
- Final Form 8858
- Files initial Form 5471

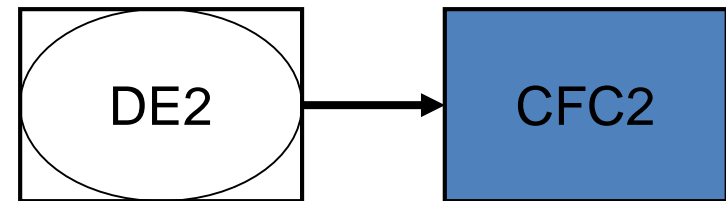

Possible Transactions (Cont'd)

- **DE10**
 - When DE2 elected to be regarded, that also caused the outbound transfer of DE10...

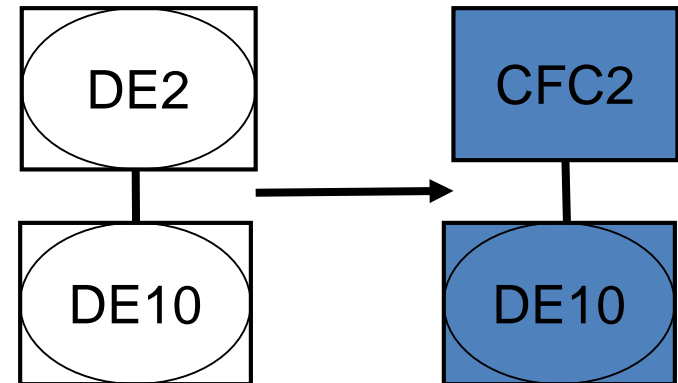

Possible Transactions (Cont'd)

■ DE10

- ...DE10 remained a DE until USP contributed additional assets amounting to 80% of the value of DE10 in exchange for an 80% interest of the entity
- Now having more than one owner, it can no longer be disregarded. It undergoes a *per se* classification change to a partnership (retaining the passthrough nature of a DE)
- A Form 8832 entity change form is not necessary
- It must now file a final Form 8858 and initial Form 8865

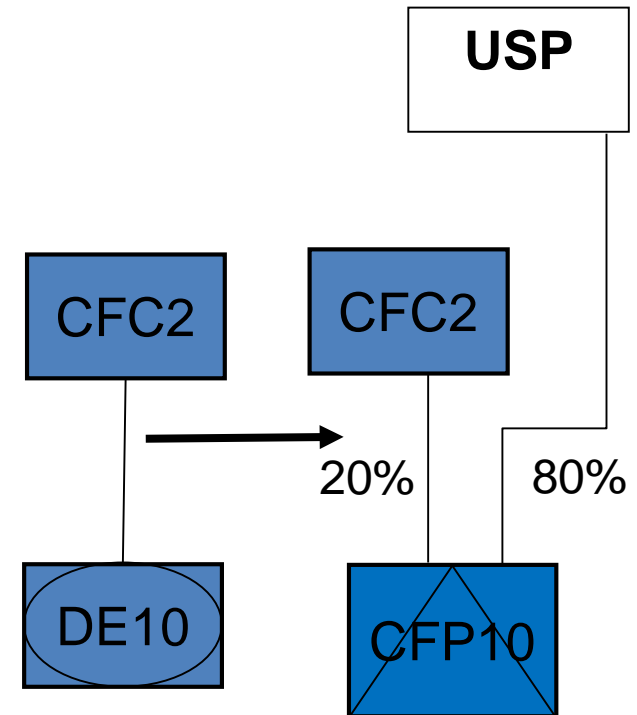

Possible Transactions (Cont'd)

■ US Sub4

- Outbound transfer of property
- USP files Form 926 for assets of US Sub4
- Likely files a Gain Recognition Agreement (GRA)
- Files initial Form 5471

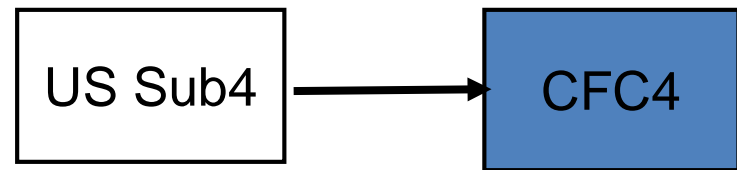

■ CFC3

- Parent would file Form 926 for its stock owned by US Sub4
- GRA likely filed for CFC3 stock
- Continues to file its Form 5471

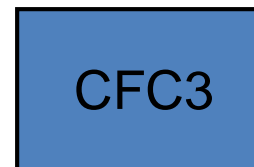

Possible Transactions (Cont'd)

■ CFC5

- Foreign to foreign transfer, so no GRA needed
- Final Form 5471
- Files Form 8832
- Files initial Form 8858

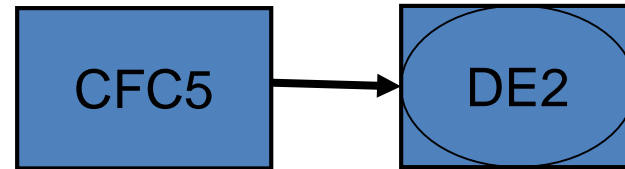

■ CFC9

- No change

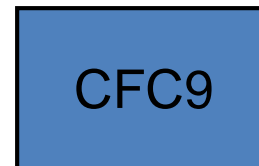

■ CFC6

- No change

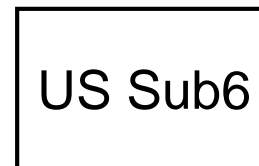



C. Common Global Tax Structures in International Tax Planning



**Large Business
& International**

Outbound Transactions and ETR

- Some of these activities may affect ETR
 - Income shifting
 - FDII maximization
 - BEAT minimization
 - Expense allocation and apportionment
 - Affirmative subpart F use
 - FTC maximization
 - GILTI reduction management
 - Participation exemption/Dividend Received Deduction (DRD) maximization
 - Manage interest expense allocation
 - Loss importation

Outbound Transaction Example and ETR (Pre-TCJA)

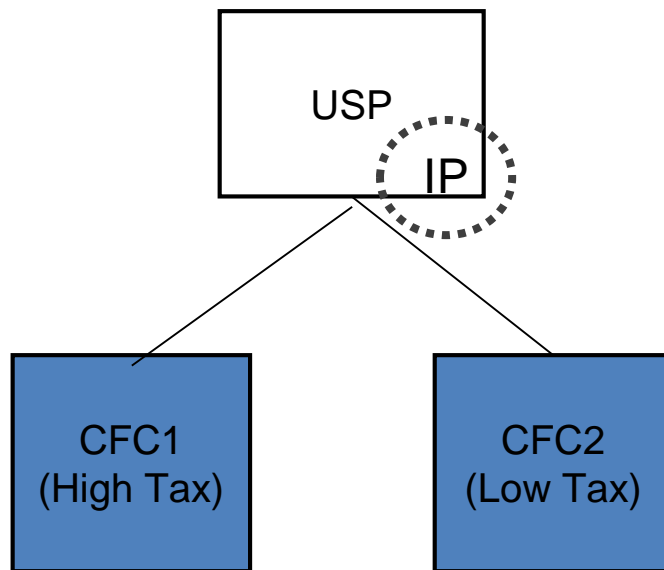

Possible tax strategies

- Transfer pricing
- Transfer IP offshore followed by license of IP
- E&P segregation
- FTC “hyping”
- Avoiding subpart F

Outbound Transaction Example and GILTI (Post-TCJA)

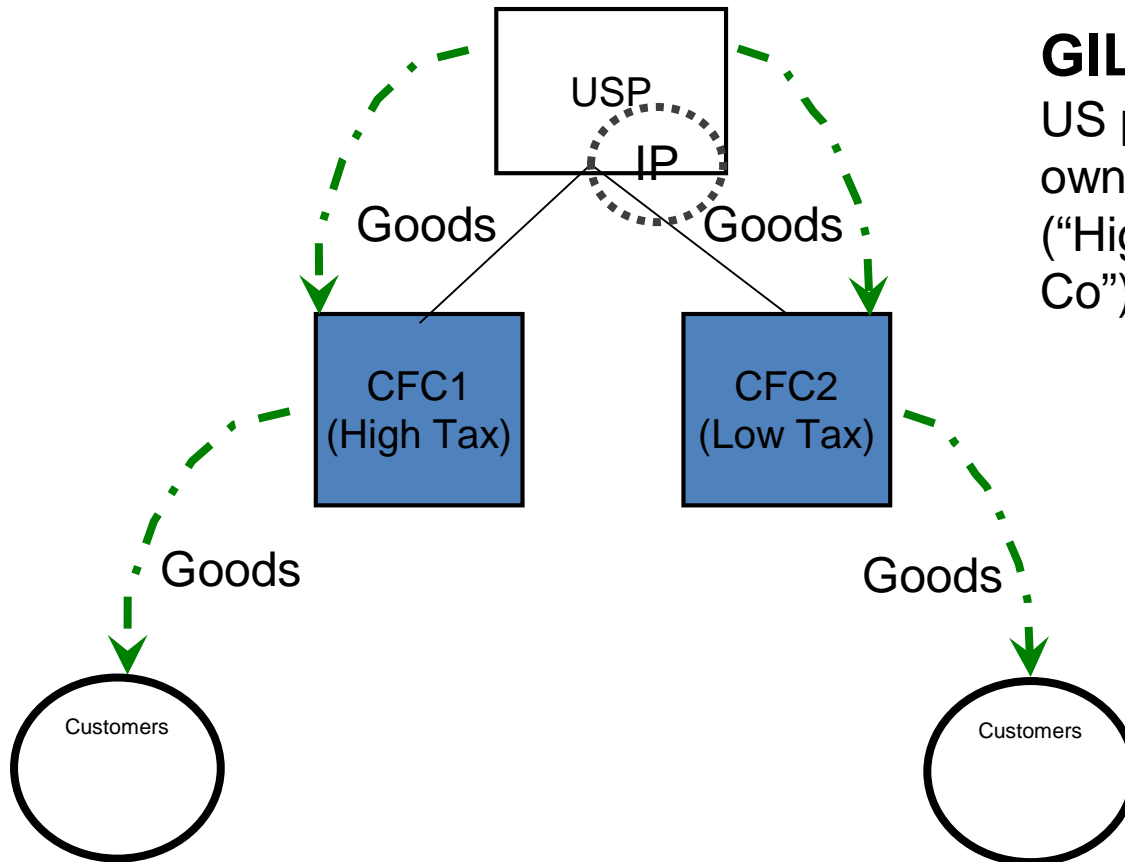

GILTI Effect

US parent corporation wholly owns two foreign corporations (“High Tax Co”) and (“Low Tax Co”)

- USP performs manufacturing
- USP owns the global IP
- USP transfers IP to offshore foreign affiliates
- USP sells widgets to High Tax Co and Low Tax Co based on a resale minus
- The overall foreign tax rate is 27%

Outbound Transaction Example and GILTI (Post-TCJA) (Cont'd)

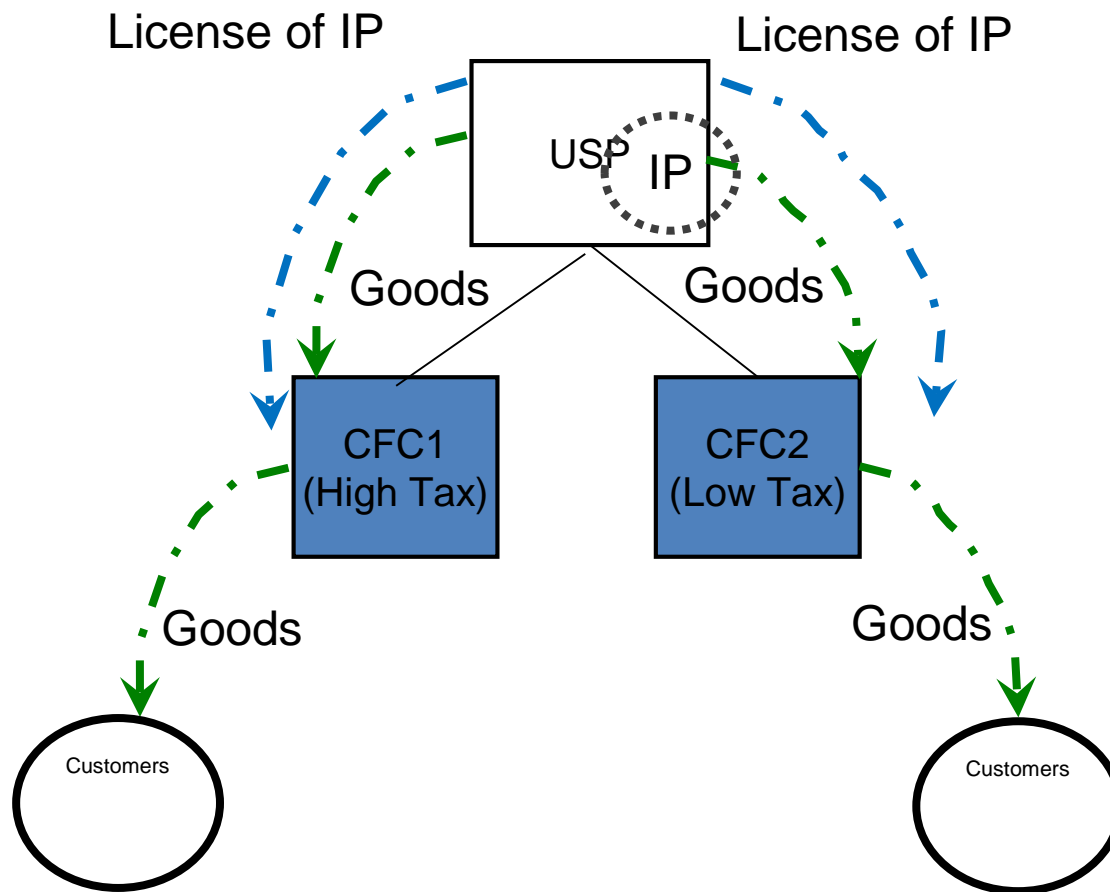

Possible tax issues

- USP could be in situation where excess FTCs are permanently lost. What can it do?
- Separate price of intangibles from the sale of goods
 - May create significant low-tax, foreign-source, general basket income.

Outbound Transaction to Minimize ETR and GILTI (Post-TCJA) (Cont'd)

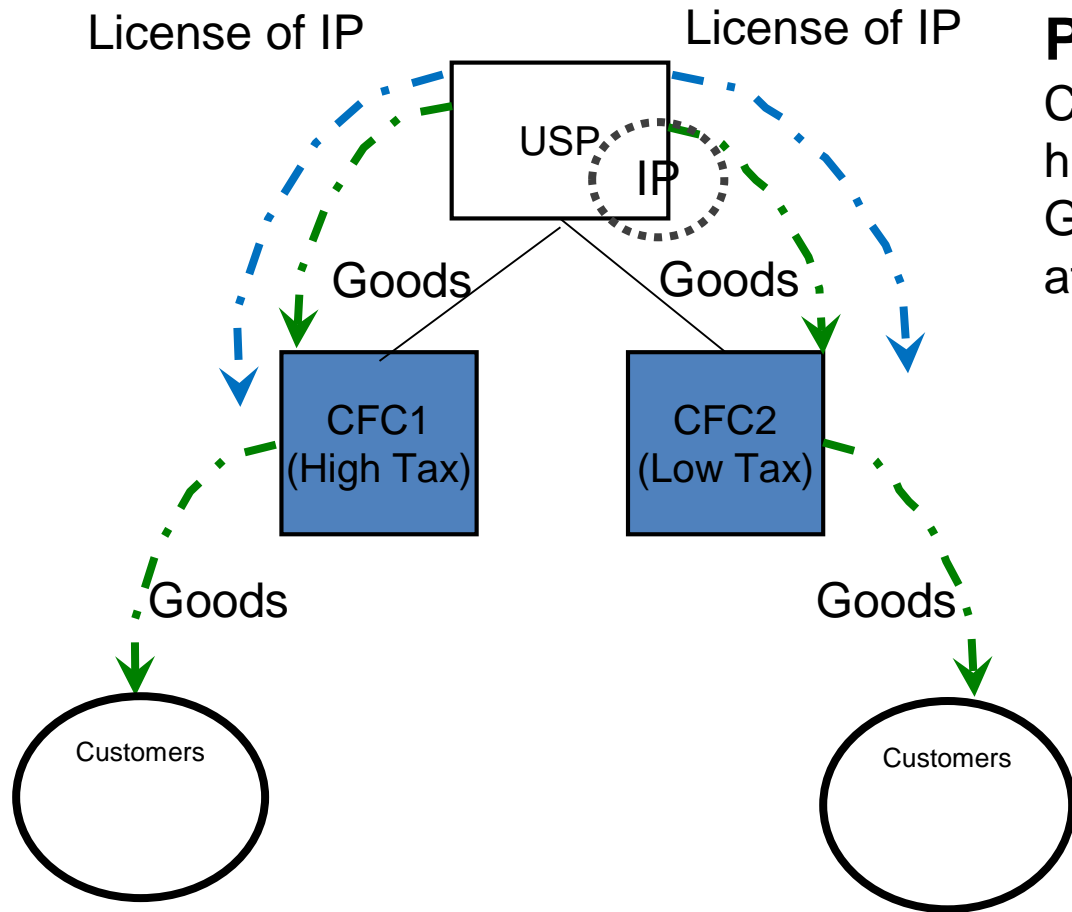

Possible tax issues

Could potentially blend this with high-tax income currently in GILTI basket through affirmative Subpart F planning?

- By engaging in this planning (separating royalty and then affirmative Subpart F planning), USP has optimized its tax position and maximized FTC utilization?
- IP royalties may also produce FDII

Inbound Transactions and ETR

- Taxpayers may use one or more of the following typical transactions to minimize ETR
 - Efficient use of entity classification rules
 - Expense allocations to US branch/PE
 - Income shifting
 - Loans through low-tax affiliates
 - Section 163(j) optimization
 - Foreign guarantees
 - BEAT minimization
 - FDII maximization

Inbound Transaction Example and ETR (Pre-TCJA)

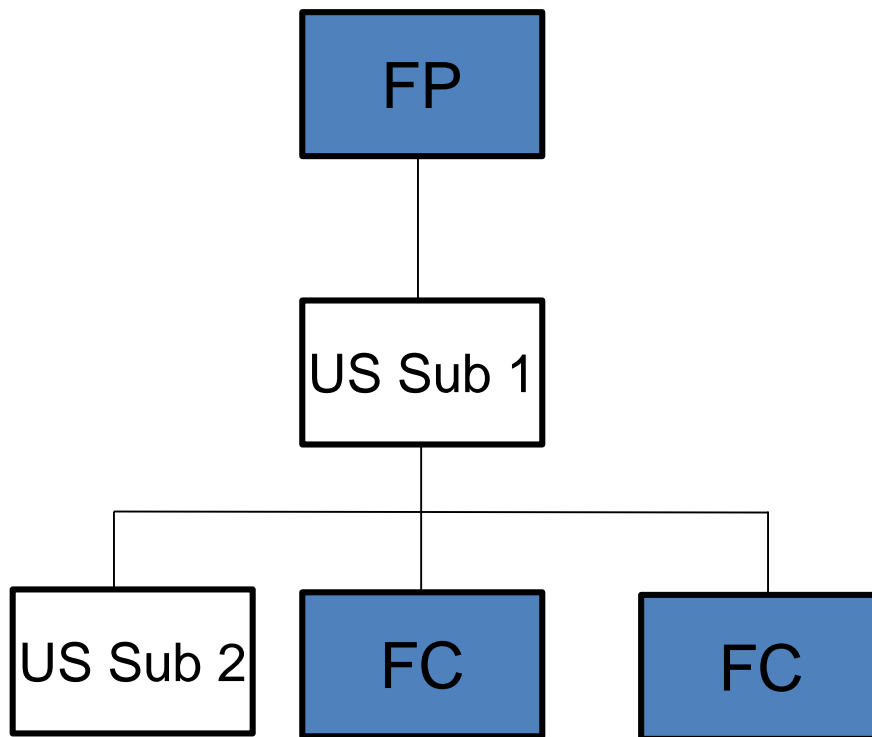

Possible tax issues

- US Sub 1 enters into loan with FP
- US Sub 1 pays management and oversight fees
- Transfer pricing

Inbound Transaction Example and ETR (Post-TCJA)

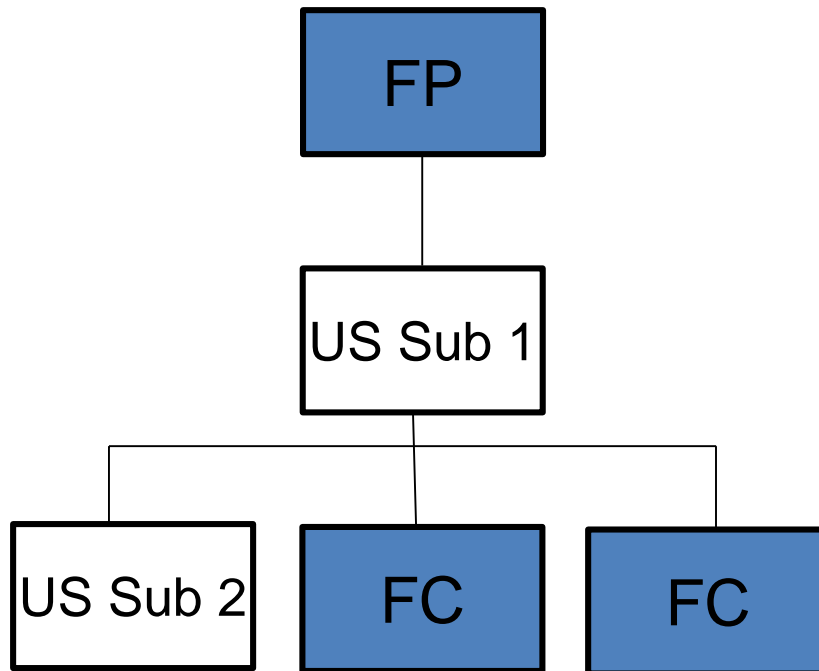

- Related party loans are subject to new rules: BEAT, IRC 163(j) (modified old section 163(j), and new hybrid rules
- Following US tax strategies may still be employed:
 - Allocation and apportionment of overhead expenses
 - Transfer pricing
 - Optimizing BEAT and IRC 163(j) calculations



What did we learn?



**Large Business
& International**

Summary

You should now be able to:

- A. Identify taxpayer's objectives in global tax planning
- B. Describe how to interpret a taxpayer's GTOC
- C. Identify typical global tax structures for international tax planning strategies

Appendix



**Large Business
& International**

Glossary of Terms

Acronym/Terms	Definition
BOY	Beginning of Year
BEAT	Base Erosion and Anti-abuse Tax
BR	True Domestic Branch for US and foreign tax purposes
CFC	Controlled Foreign Corporation
CSA	Cost Sharing Arrangement
CTB	Check-the-Box
DE	Disregarded legal entity for US Tax purposes
DRD	Dividends Received Deduction
E&P	Earnings and Profits
EOY	End of Year
ECI	Effectively Connected Income
EPS	Earnings Per Share



Glossary of Terms (Cont'd)

Acronym/Terms	Definition
ETR	Effective Tax Rate
FBR	True Foreign Branch
FC	Foreign Corporation
FDE	Foreign Disregarded Entity
FDII	Foreign Derived Intangible Income
Financial/"Book"	US GAAP Financial Book income
FP	Foreign Parent Company
FSI	Foreign Source Income
FTC	Foreign Tax Credit
FTR	Foreign Tax Rate
GTOC	Global Tax Organizational Chart
GILTI	Global Intangible Low-Taxed Income
GRA	Gain Recognition Agreement



Glossary of Terms (Cont'd)

Acronym/Terms	Definition
Holdco	Holding Company
Hubco	Foreign holding company organized in a low-tax jurisdiction, often vested with centralized functions and centralized control of IP
Hybrid	Hybrid: Flow through for US tax/Corporation for country of incorporation
HP	Hybrid Partnership
IBC	International Business Company
IP	Intangible Property
IDR	Information Document Request
LLC	Limited Liability Company
MNE	Multinational Entity
PRI	Permanently Reinvested Income (Foreign)
QBU	Qualified Business Unit
RH	Reverse Hybrid: Corporation for US tax and flow through for foreign country of incorporation



Glossary of Terms (Cont'd)

Acronym/Terms	Definition
QBU	Qualified Business Unit
PTI	Previously Taxed Income
PTR	Partner
RH	Reverse Hybrid: Corporation for US tax and flow through for foreign country of incorporation
SEC	Securities Exchange Commission
USC	United States
USP	United States Parent
USS	United States Subsidiary
TCJA	Tax Cuts and Job Act of 2017

