

LB&I Training Tax Cuts & Jobs Act (TCJA)

**Training
Participant Guide
October 2019**

Official IRS Training Material

This material was designed specifically for training purposes only. Under no circumstances should the contents be used or cited as authority for setting or sustaining a technical position.

All names and numbers used in this material are fictitious. Screen captures included in this guide do not contain any live taxpayer information.

Welcome

LB&I Tax Cuts & Jobs Act Training



IRS Mission Statement



Mission Statement

Provide America's taxpayers top-quality service by helping them understand and meet their tax responsibilities and enforce the law with integrity and fairness to all.

14 General Principles of Ethical Conduct

Please see [Document 9300](#) for a complete list of the 14 General Principles of Ethical Conduct for Federal Employees.

Taxpayer Bill of Rights

Please see [Publication 1](#) to read the full text of Your Rights as a Taxpayer.

TCJA Course Overview

LB&I Tax Cuts & Jobs Act training sessions are a large part of LB&I's multi-pronged approach to tax reform training. This mandatory training course covers IRC § § 199A, 451, 163(j), 951A, 250, 59A, 965, 367 and 91.

Table of Contents (as originally presented)

Course Agenda.....	9
IRC § 199A (Qualified Business Income Deduction).....	12
IRC § 451 (Income Recognition Guidance).....	105
IRC § 163(j) (Limitation on Business Interest Expense).....	180
IRC § 367 & 91 (Transfer Pricing/Outbound Transfers).....	366
IRC § 951A (Global Intangible Low-Taxed Income).....	409
IRC § 250 (Foreign Derived Intangible Income).....	493
IRC § 965 (Transition Tax).....	560
IRC § 59A (Base Erosion and Anti-abuse Tax).....	690

TCJA Course Agenda

Monday - October 21, 2019

- Executive Opening, Introductions and Admin
- IRC § 199A (Qualified Business Income Deduction)

Tuesday - October 22, 2019

- IRC § 451 (Income Recognition Guidance)
- IRC § 163(j) (Limitation on Business Interest Expense)

Wednesday - October 23, 2019

- IRC § 163(j) (Limitation on Business Interest Expense) (cont'd)
- IRC § 367 & 91 (Transfer Pricing/Outbound Transfers)

TCJA Course Agenda (cont'd)

Thursday - October 24, 2019

- IRC § 951A (Global Intangible Low-Taxed Income)
- IRC § 250 (Foreign Derived Intangible Income)

Tuesday - October 29, 2019

- IRC § 965 (Transition Tax)

Wednesday - October 30, 2019



- IRC § 59A (Base Erosion and Anti-abuse Tax)

Thursday – October 31, 2019

- Final Comments and Executive Closing

LB&I Training

Tax Cuts & Jobs Act (TCJA)



IRC § 951A
Global Intangible Low-Taxed Income (GILTI)



**Large Business
& International**

Instructor Introductions

Instructor Introductions

Lesson Description

This lesson will explain what Global Intangible Low-Taxed Income (“GILTI”) is. It will also teach agents how to identify US shareholders and CFCs, compute a US shareholder’s GILTI inclusion, and describe the foreign tax credit implications, if any. It covers similarities and differences between subpart F income and GILTI.

These materials are not to be used or cited as precedent. They may not be complete or final, as they are intended to be general training materials designed to introduce IRS personnel to TCJA-related topics and have been simplified for that purpose.

Lesson Objectives

At the end of this lesson, you will be able to:

- Identify US shareholders and controlled foreign corporations (“CFCs”);
- Describe the new GILTI regime;
- Apply the new GILTI rules;
- Describe the FTC implications for GILTI;
- Compare and contrast the GILTI and subpart F regimes;
- Identify relevant forms; and
- Identify taxpayer planning strategies and key takeaways.

United States Shareholders and Foreign Corporations

United States Shareholder

- A **US shareholder** is a US person (as defined in §957(c)) who owns, directly, indirectly, or constructively, 10% or more of the vote or value (added by TCJA) of a foreign corporation. §951(b).
- A US person is generally defined by reference to §7701(a)(30) of the Code, which includes the following:
 - A US citizen or resident,
 - A domestic partnership,
 - A domestic corporation,
 - Any estate (that is not foreign), and
 - Any trust if a US court has jurisdiction over its administration and one or more US persons have the authority to control all substantial decisions of the trust.

Controlled Foreign Corporation

- A **CFC** is any foreign corporation in which more than 50% of the vote or value is owned, directly, indirectly, or constructively, by US shareholders. §957(a).
- §958(a) has rules regarding direct and indirect (through foreign entities) ownership.
- §958(b) has rules regarding constructive ownership.
- TCJA repealed §958(b)(4).

Controlled Foreign Corporation

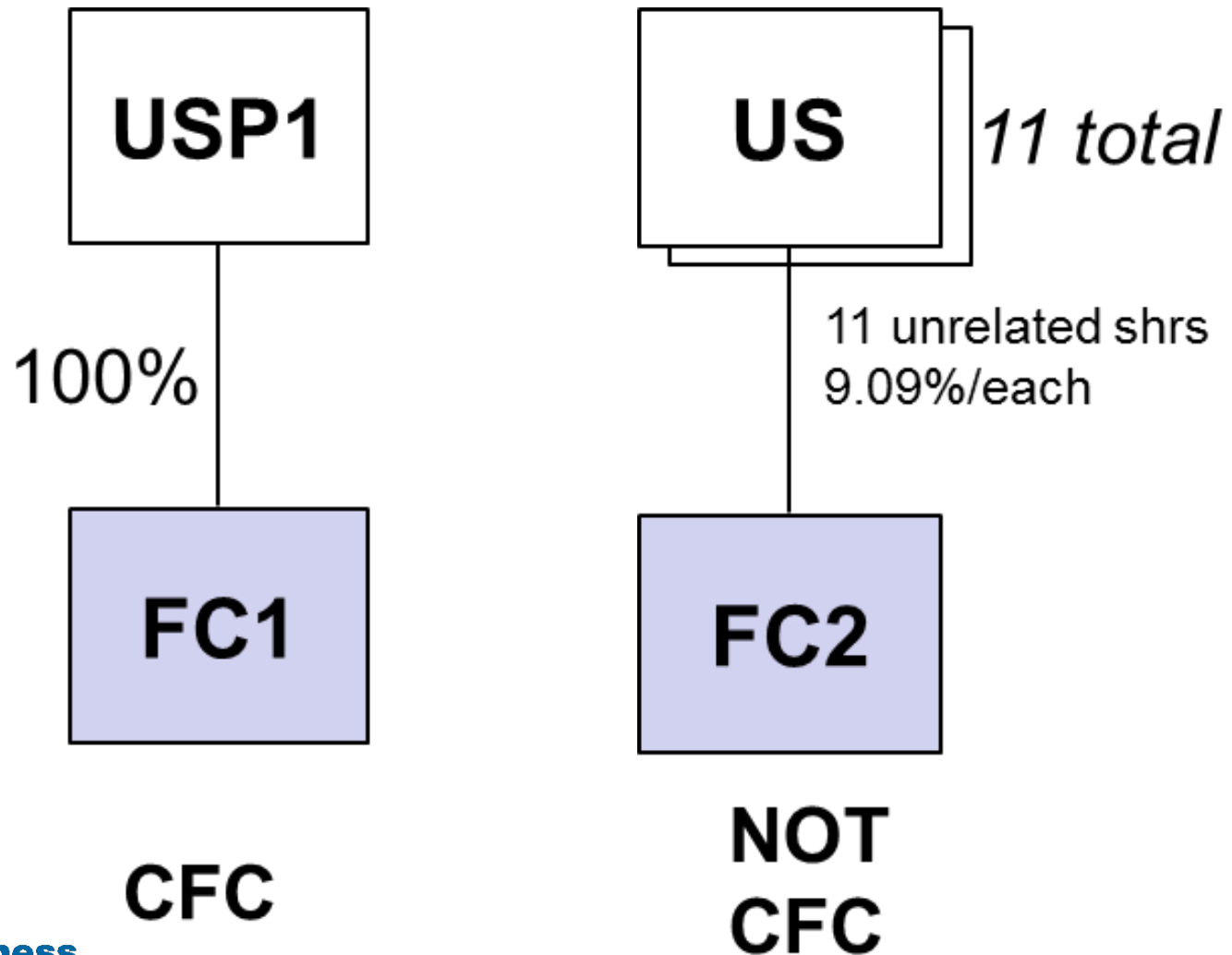

Controlled Foreign Corporation

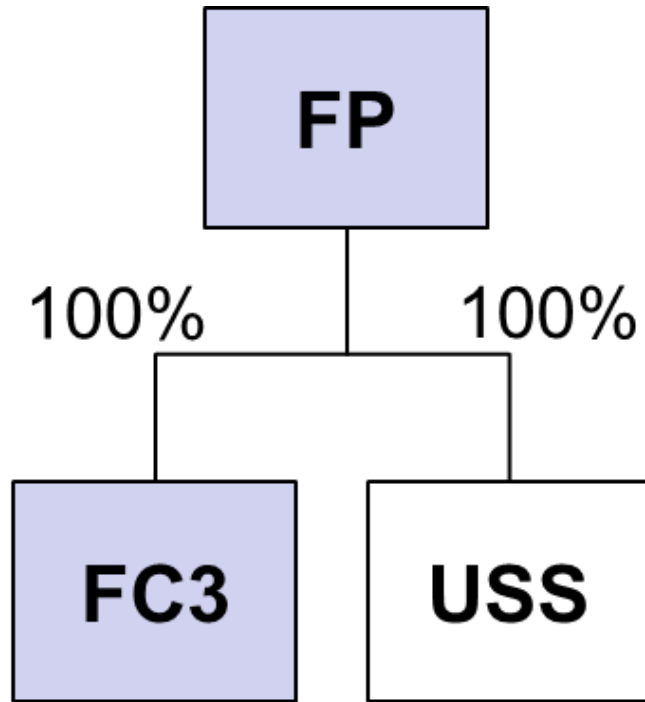

CFC (but no §958(a) shareholder)

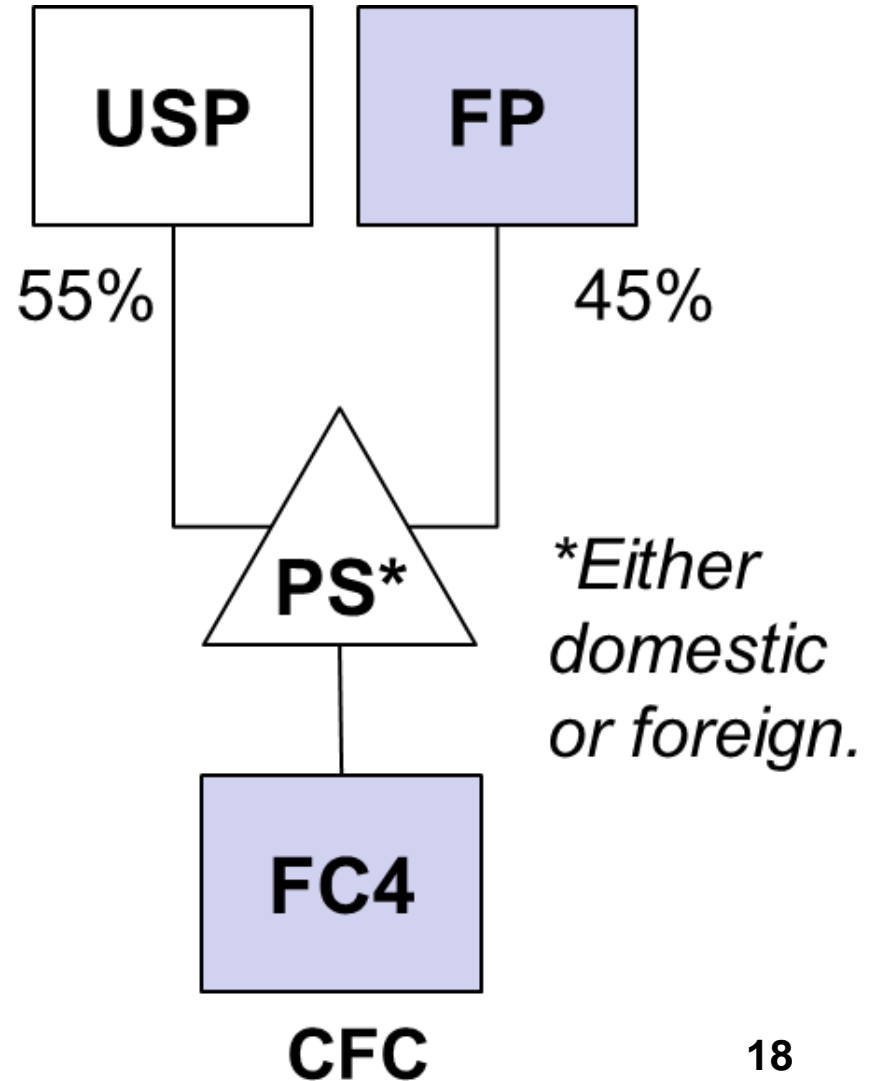

GILTI and Domestic Partnerships

- A domestic partnership is treated as owning stock of a foreign corporation within the meaning of §958(a) only to determine the following:
 - (1) whether any US person is a US shareholder,
 - (2) whether any US shareholder is a controlling domestic shareholder, or
 - (3) whether any foreign corporation is a CFC.

GILTI and Domestic Partnerships

- For purposes of determining of GILTI:
 - a domestic partnership is not treated as owning the stock of the foreign corporation within the meaning of §958(a).
 - a domestic partnership is treated as an aggregate of its partners for purposes of determining who owns the stock of the foreign corporation within the meaning of §958(a).
- This matters because only persons who own stock of a foreign corporation within the meaning of §958(a) include GILTI.
- It means that the partners of a domestic partnership, and not the domestic partnership, would have to include any GILTI in their gross income. See Treas. Reg. §1.951A-1(e).

GILTI and Domestic Partnerships

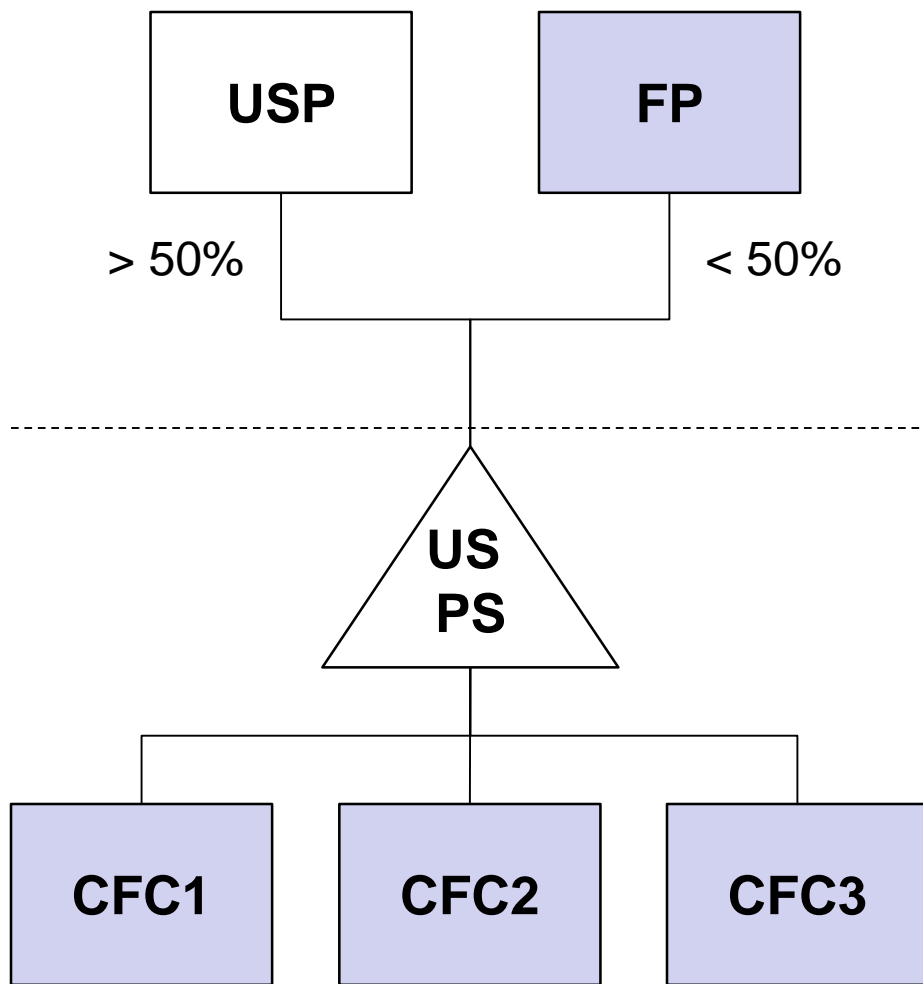

Aggregate treatment

To determine:

- The persons that own stock of the foreign corporation within the meaning of §958(a), i.e., who has a GILTI inclusion.

Entity treatment

To determine whether:

- Any US person is a US shareholder,
- Any US shareholder is a controlling domestic shareholder; and
- Any foreign corporation is a CFC

GILTI and Domestic Partnerships

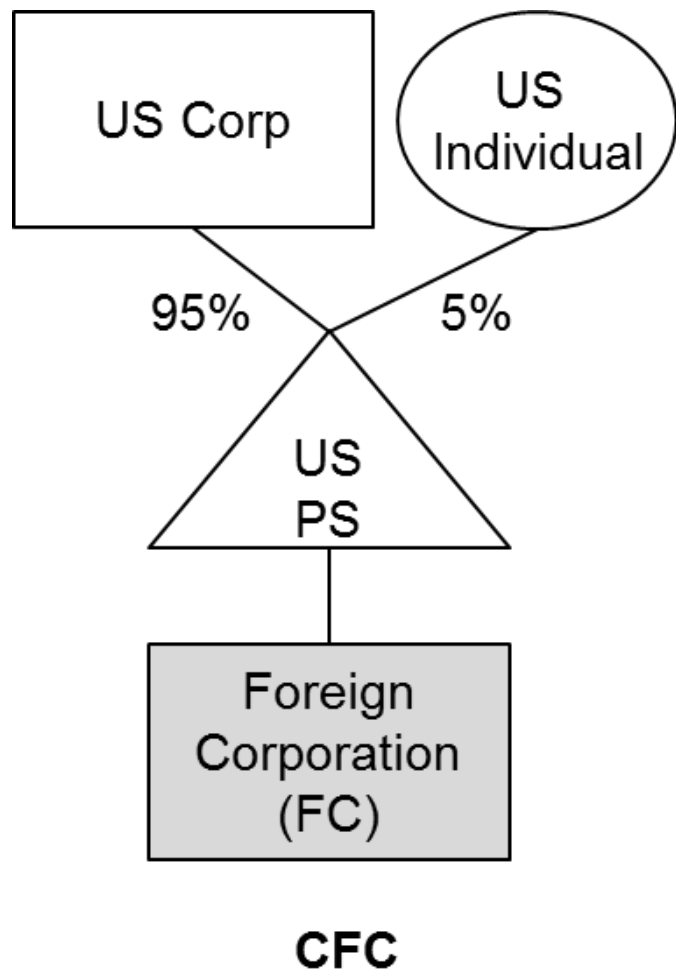

- US PS (direct owner of FC) and US Corp (constructive owner of 95% of FC under §958(b)) are US shareholders of FC. US Individual is not a US shareholder of FC.
- FC is a CFC because US shareholders own more than 50%.
- For purposes of GILTI, only §958(a) owners have to do a computation, and for this purpose, US PS is treated as foreign, resulting in US Corp owning 95% of FC under §958(a)(2). US Corp will compute its GILTI, and US PS and US Individual do not compute a GILTI amount.

GILTI Regime

GILTI Formula

$$\text{GILTI} = \text{Net CFC Tested Income} - \text{Net DTIR}$$

GILTI Formula

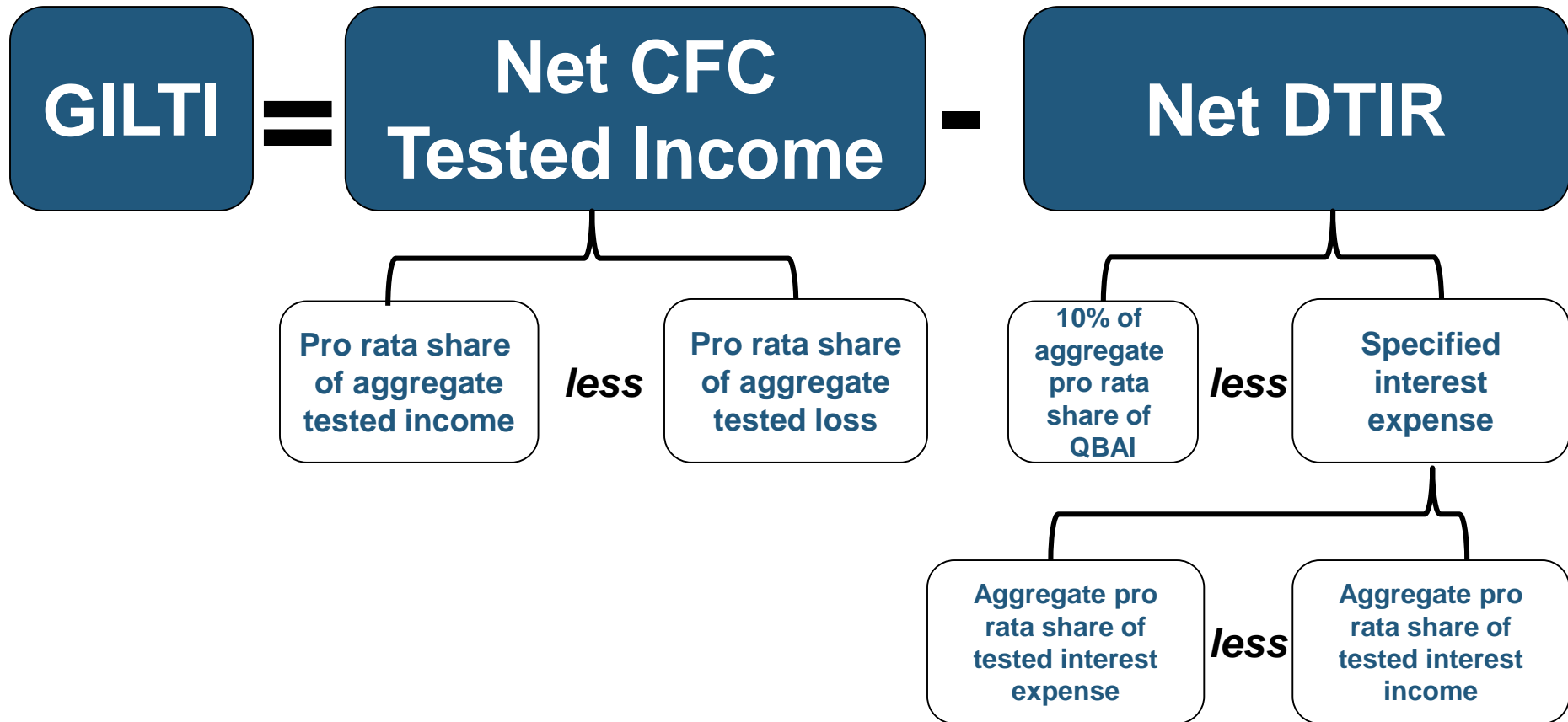

Pro rata share rule

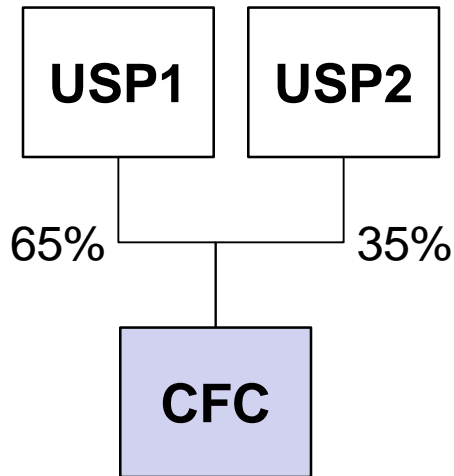

- **USP1** has a pro rata share of 65% of CFC's items.
- **USP2** has a pro rata share of 35% of CFC's items

Pro rata share

- Amount determined “under the rules of section 951(a)(2) in the same manner as such section applies to subpart F income.” §951A(e)(1).
- Subpart F income – Proportionate to the amount that would be received by the shareholder in a year-end hypothetical distribution of all the CFC's current-year earnings relative to all the current-year earnings. §1.951-1(b).
- GILTI items – Generally, the same as the subpart F income rule but with some modifications. §1.951A-1(d).

Computing GILTI

Net CFC Tested Income

less

Net DTIR

Aggregate pro
rata share of
tested income

less

Aggregate pro
rata share of
tested loss

10% of
aggregate pro
rata share of
QBAI

less

Specified
interest
expense



GILTI Key Terms

<p>Net CFC tested income</p>	<p>Excess of the aggregate of the US shareholder's pro rata share of tested income of each CFC, over aggregate of US shareholder's pro rata share of tested loss of each CFC. §951A(c)(1) and Treas. Reg. §1.951A-1(c)(2).</p>
<p>Net deemed tangible income return (Net DTIR)</p>	<p>Excess of 10% of the aggregate of the US shareholder's pro rata share of QBAI of each CFC, over the specified interest expense. §951A(b)(2) and Treas. Reg. §1.951A-1(c)(3)(i).</p>
<p>Qualified business asset investment (QBAI)</p>	<p>Average of a tested income CFC's aggregate adjusted bases as of the close of each quarter of a CFC's year in specified tangible property that is used in a trade or business of the tested income CFC and is of a type with respect to which a deduction is allowable under §167. §951A(d)(1) and Treas. Reg. §1.951A-3(b).</p>
<p>Specified interest expense</p>	<p>The excess of the aggregate of the US shareholder's pro rata share of each CFC's tested interest expense over the aggregate of the US shareholder's pro rata share of each CFC's tested interest income. Treas. Reg. §1.951A-1(c)(3)(iii).</p>

US shareholder-level vs. CFC-level items

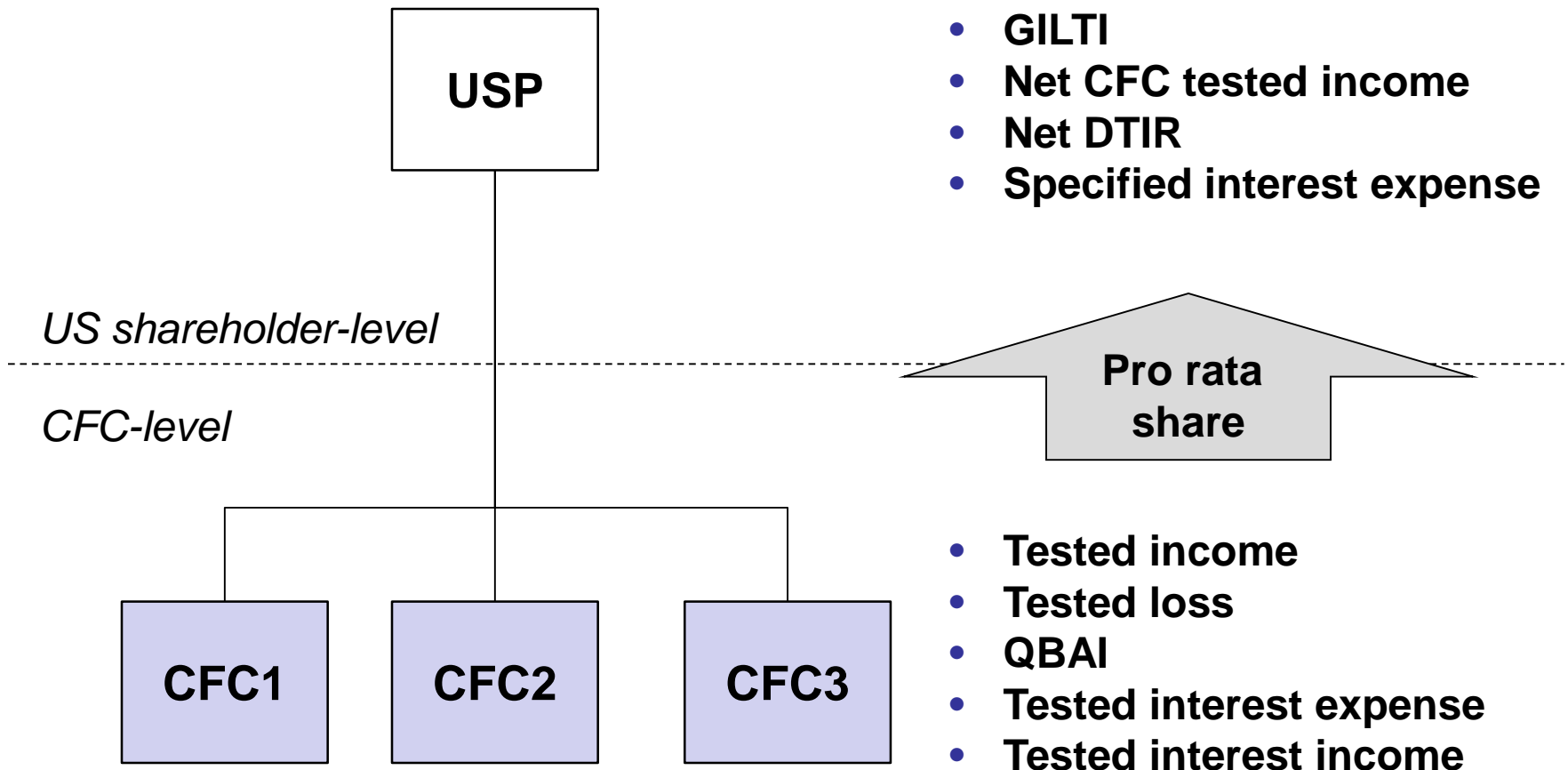

Computing GILTI

Net CFC Tested Income

less

Net DTIR

Aggregate pro
rata share of
tested income

less

Aggregate pro
rata share of
tested loss

10% of
aggregate pro
rata share of
QBAI

less

Specified
interest
expense

GILTI Key Terms

<p>Net CFC tested income</p>	<p>Excess of the aggregate of the US shareholder's pro rata share of tested income of each CFC, over aggregate of US shareholder's pro rata share of tested loss of each CFC. §951A(c)(1) and Treas. Reg. §1.951A-1(c)(2).</p>
<p>Net deemed tangible income return (Net DTIR)</p>	<p>Excess of 10% of the aggregate of the US shareholder's pro rata share of QBAI of each CFC, over the specified interest expense. §951A(b)(2) and Treas. Reg. §1.951A-1(c)(3)(i).</p>
<p>Qualified business asset investment (QBAI)</p>	<p>Average of a tested income CFC's aggregate adjusted bases as of the close of each quarter of a CFC's year in specified tangible property that is used in a trade or business of the tested income CFC and is of a type with respect to which a deduction is allowable under §167. §951A(d)(1) and Treas. Reg. §1.951A-3(b).</p>
<p>Specified interest expense</p>	<p>The excess of the aggregate of the US shareholder's pro rata share of each CFC's tested interest expense over the aggregate of the US shareholder's pro rata share of each CFC's tested interest income. Treas. Reg. §1.951A-1(c)(3)(iii).</p>

Tested Income and Tested Loss

$$\text{Tested income} = \text{Gross tested income} \text{ less } \text{Allocable deductions}$$

- Tested income and tested loss are CFC-level items, the pro rata shares of which flow up to the US shareholder.
- Tested income is not limited to the CFC's current E&P.
- CFC tested income (or loss) is calculated according to US taxable income principles (see Treas. Reg. §1.952-2).

Section 951A(c)(2)(A) and Treas. Reg. §1.951A-2(b)(1).



Tested Income and Tested Loss

$$\text{Tested income} = \text{Gross tested income} \text{ less Allocable deductions}$$

Gross tested income is gross income less the following excluded items:*

1. US source income effectively connected with the conduct of a trade or business by the CFC in the United States (“ECI”);
2. Gross income taken into account in determining the CFC’s subpart F income;
3. Gross income excluded from the CFC’s foreign base company income (“FBCI”) and insurance income by reason of the high-tax exception in §954(b)(4);
4. Dividends received from a related person; and
5. Foreign oil and gas extraction income (“FOGEI”).



Tested Income and Tested Loss

$$\text{Tested income} = \text{Gross tested income} \text{ less } \text{Allocable deductions}$$

- Deductions (including taxes) properly allocable to gross tested income are determined similar to the rules of 954(b)(5).

Tested Income and Tested Loss

Tested loss

=

**Allocable
deductions**

-

**Gross tested
income**

Tested loss is the excess of allocable deductions over gross tested income, i.e., when $\text{Gross Tested Income} - \text{Allocable Deductions} < 0$

In any given tax year, a CFC is either...

- a tested income CFC **or**
- a tested loss CFC,

...**not** both!



Tested Income Example

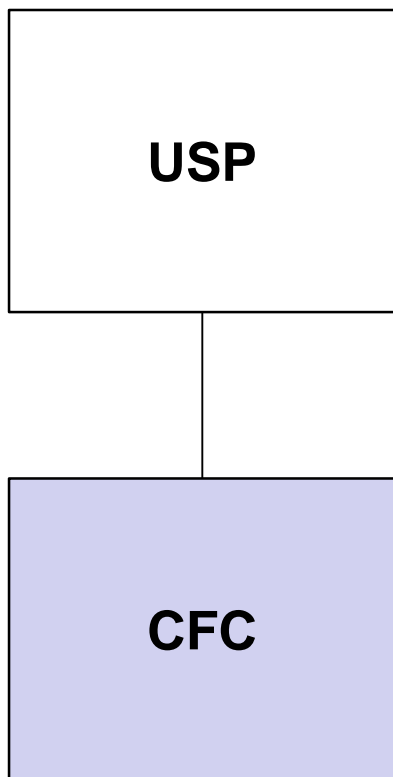

FBCSI: 100x
FOGEI: 75x
Other income: 50x

Facts:

- CFC has gross income of 225x, of which there is FBC sales income of 100x, FOGEI of \$75x, and other income of 50x.

Analysis:

- CFC's gross tested income is 50x because subpart F income and FOGEI are excluded from gross tested income.

Tested Income Example (cont'd)

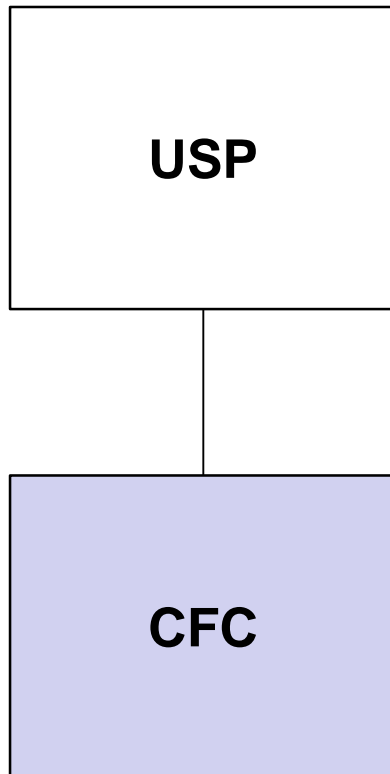

FBCSI: 100x
FOGEI: 75x
Other income: 50x

FACTS:

- CFC has gross income of 225x, of which there is FBC sales income of 100x, FOGEI of \$75x, and other income of 50x.
- CFC has deductions properly allocable to gross tested income of 80x.

ANALYSIS:

- CFC has a tested loss because its properly allocable deductions are greater than its gross tested income.
- CFC's tested loss is 30x (the properly allocable deductions of 80x exceed gross tested income of 50x by 30x).

Net CFC Tested Income Example

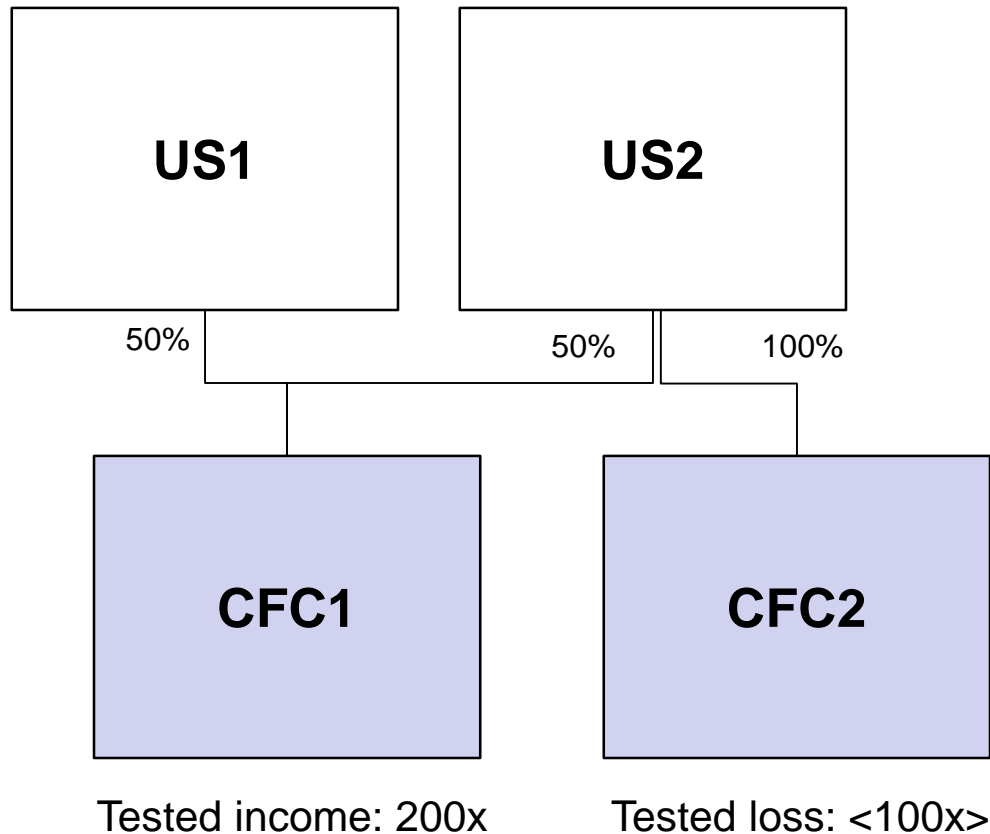

Facts:

- CFC1 has tested income of 200x.
- CFC2 has a tested loss of 100x.

Analysis:

- US1's net CFC tested income is 100x (50% of 200x).
- US2's net CFC tested income is -0- (50% of 200x and 100% of <100x>).

Computing GILTI

Net CFC Tested Income

less

Net DTIR

Aggregate pro
rata share of
tested income

less

Aggregate pro
rata share of
tested loss

10% of
aggregate pro
rata share of
QBAI

less

Specified
interest
expense



GILTI Key Terms

<p>Net CFC tested income</p>	<p>Excess of the aggregate of the US shareholder's pro rata share of tested income of each CFC, over aggregate of US shareholder's pro rata share of tested loss of each CFC. §951A(c)(1) and Treas. Reg. §1.951A-1(c)(2).</p>
<p>Net deemed tangible income return (Net DTIR)</p>	<p>Excess of 10% of the aggregate of the US shareholder's pro rata share of QBAI of each CFC, over the specified interest expense. §951A(b)(2) and Treas. Reg. §1.951A-1(c)(3)(i).</p>
<p>Qualified business asset investment (QBAI)</p>	<p>Average of a tested income CFC's aggregate adjusted bases as of the close of each quarter of a CFC's year in specified tangible property that is used in a trade or business of the tested income CFC and is of a type with respect to which a deduction is allowable under §167. §951A(d)(1) and Treas. Reg. §1.951A-3(b).</p>
<p>Specified interest expense</p>	<p>The excess of the aggregate of the US shareholder's pro rata share of each CFC's tested interest expense over the aggregate of the US shareholder's pro rata share of each CFC's tested interest income. Treas. Reg. §1.951A-1(c)(3)(iii).</p>

Computing GILTI

Net CFC Tested Income

less

Net DTIR

Aggregate pro
rata share of
tested income

less

Aggregate pro
rata share of
tested loss

10% of
aggregate pro
rata share of
QBAI

less

Specified
interest
expense

GILTI Key Terms

<p>Net CFC tested income</p>	<p>Excess of the aggregate of the US shareholder's pro rata share of tested income of each CFC, over aggregate of US shareholder's pro rata share of tested loss of each CFC. §951A(c)(1) and Treas. Reg. §1.951A-1(c)(2).</p>
<p>Net deemed tangible income return (Net DTIR)</p>	<p>Excess of 10% of the aggregate of the US shareholder's pro rata share of QBAI of each CFC, over the specified interest expense. §951A(b)(2) and Treas. Reg. §1.951A-1(c)(3)(i).</p>
<p>Qualified business asset investment (QBAI)</p>	<p>Average of a tested income CFC's aggregate adjusted bases as of the close of each quarter of a CFC's year in specified tangible property that is used in a trade or business of the tested income CFC and is of a type with respect to which a deduction is allowable under §167. §951A(d)(1) and Treas. Reg. §1.951A-3(b).</p>
<p>Specified interest expense</p>	<p>The excess of the aggregate of the US shareholder's pro rata share of each CFC's tested interest expense over the aggregate of the US shareholder's pro rata share of each CFC's tested interest income. Treas. Reg. §1.951A-1(c)(3)(iii).</p>

QBAI

- QBAI is a CFC-level attribute.
- QBAI is the average of the CFC's aggregate adjusted bases at the end of each quarter in depreciable **specified tangible property** that is used in a trade or business. §951A(d)(1) and Treas. Reg. §1.951A-3(b).
- **Specified tangible property** is tangible property used in the production of tested income. §951A(d)(2)(A) and Treas. Reg. §1.951A-3(c)(1).
- Tangible property is used in the production of gross tested income if some/all of its depreciation is allocated/apportioned to gross tested income (or capitalized to inventory/property held for sale, where some/all the income/loss from the sale is included in tested income). Treas. Reg. §1.951A-3(c)(1).

QBAI

- A tested loss CFC does not have QBAI (but see slides on tested loss notional QBAI rule). Treas. Reg. §1.951A-3(b).
- For purposes of determining QBAI, adjusted basis is generally determined using the alternative depreciation system (ADS). §951A(d)(3)(A) and Treas. Reg. §1.951A-3(e)(1). However, the final GILTI regulations allow taxpayers to elect to use a CFC's book depreciation in certain situations.
- If specified tangible property is used to produce both tested income and income other than tested income (**dual-use property**), a proportionate amount of property is treated as specified tangible property. §951A(d)(2)(B) and Treas. Reg. §1.951A-3(d)(1).

QBAI Example

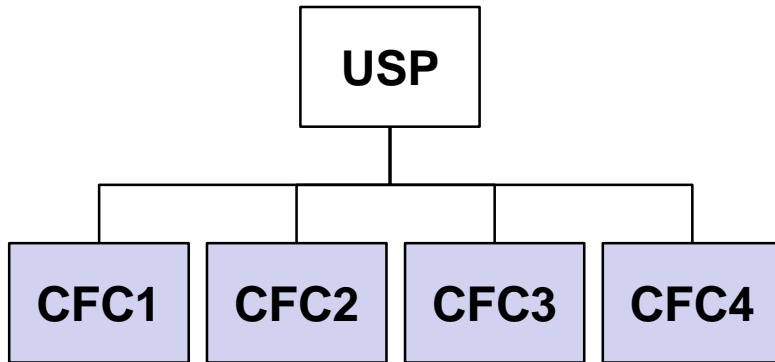

	CFC1	CFC2	CFC3	CFC4
Gross TI / (TL)	500x	100x	300x	0
Deductions properly allocable	200x	50x	100x	300x
TI / (TL)	300x	50x	200x	<300x>

FACTS:

- USP owns 100% of CFC1, CFC2, CFC3, and CFC4.
- CFC1's only asset is a truck that has an adjusted tax basis of 100x.
- CFC2 owns a building that it uses for its business with an adjusted tax basis of 600x. CFC2 also owns another building that it bought as an investment for 1,000x.
- CFC3 owns machinery and equipment that has an adjusted tax basis of 300x and IP rights that have an adjusted tax basis of 500x.
- CFC4 owns an office building with an adjusted tax basis of 800x.

QBAI Example 1 (cont'd)

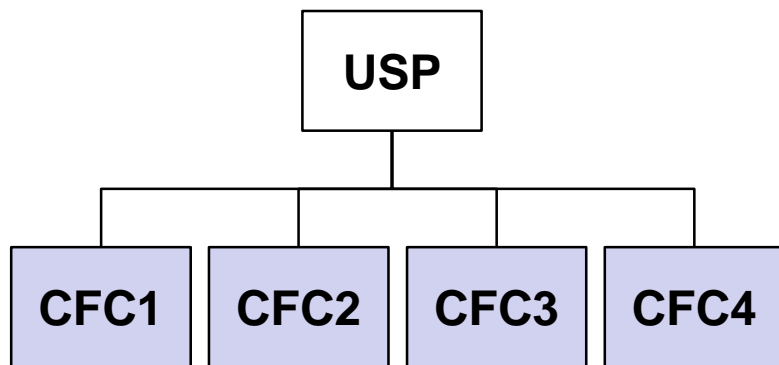

	CFC1	CFC2	CFC3	CFC4
TI / (TL)	300x	50x	200x	<300x>
QBAI	100x	600x	300x	-0-

ANALYSIS:

- CFC1's QBAI is 100x.
- CFC2's QBAI is only 600x because the second building is not used in the production of tested income.
- CFC3's QBAI is 300x and does not include the basis in the IP rights because the IP rights are not tangible property.
- CFC4 does not have QBAI because it does not have tested income.

QBAI Example

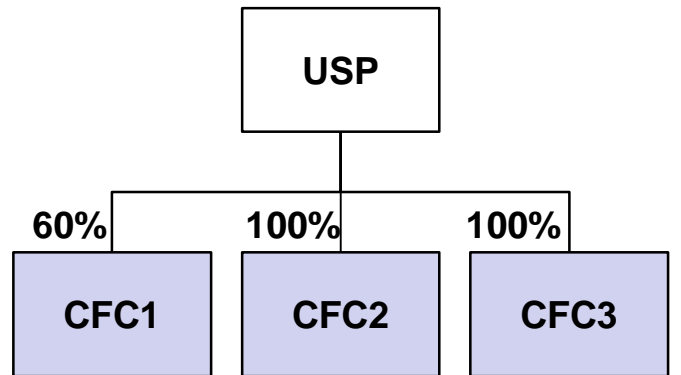

	CFC1	CFC2	CFC3
TI / (TL)	100x	40x	(40x)
QBAI	200x	50x	

FACTS:

- QBAI:
 - CFC1: 200x
 - CFC2: 50x
 - CFC3: -0- (because of tested loss)
- Specified interest expense: -0-

ANALYSIS:

- USP's net CFC tested income equals 60x
 - $[(60\% \times 100x) + (100\% \times 40x)] - (100\% \times 40x)$
- USP's net DTIR equals 17x
 - $10\% \times [(60\% \times 200x) + (100\% \times 50x)]$
- USP's GILTI inclusion is 43x (60x - \$17x)

QBAI Example 2 (cont'd)

Net CFC Tested Income

less

Net DTIR

Aggregate
tested income

less

Aggregate
tested loss

10% of QBAI

less

Specified
interest
expense

(100x – 40x)

less

(17x – 0)

$(60\% \times 100x) +$
 $(100\% \times 40x)$

less

$(100\% \times 40x)$

$10\% \times$
 $[(60\% \times 200x) +$
 $(100\% \times 50x)]$

0



Questions



Computing GILTI

Net CFC Tested Income

less

Net DTIR

Aggregate pro
rata share of
tested income

less

Aggregate pro
rata share of
tested loss

10% of
aggregate pro
rata share of
QBAI

less

Specified
interest
expense

GILTI Key Terms

<p>Net CFC tested income</p>	<p>Excess of the aggregate of the US shareholder's pro rata share of tested income of each CFC, over aggregate of US shareholder's pro rata share of tested loss of each CFC. §951A(c)(1) and Treas. Reg. §1.951A-1(c)(2).</p>
<p>Net deemed tangible income return (Net DTIR)</p>	<p>Excess of 10% of the aggregate of the US shareholder's pro rata share of QBAI of each CFC, over the specified interest expense. §951A(b)(2) and Treas. Reg. §1.951A-1(c)(3)(i).</p>
<p>Qualified business asset investment (QBAI)</p>	<p>Average of a tested income CFC's aggregate adjusted bases as of the close of each quarter of a CFC's year in specified tangible property that is used in a trade or business of the tested income CFC and is of a type with respect to which a deduction is allowable under §167. §951A(d)(1) and Treas. Reg. §1.951A-3(b).</p>
<p>Specified interest expense</p>	<p>The excess of the aggregate of the US shareholder's pro rata share of each CFC's tested interest expense over the aggregate of the US shareholder's pro rata share of each CFC's tested interest income. Treas. Reg. §1.951A-1(c)(3)(iii).</p>

Specified Interest Expense

- US shareholder-level item.
- The excess of the aggregate of the US shareholder's pro rata share of each CFC's tested interest expense over the aggregate of the US shareholder's pro rata share of each CFC's tested interest income. Treas. Reg. §1.951A-1(c)(3)(iii).
- Tested interest expense is interest expense that is included in the deductions properly allocable to gross tested income.
- Tested interest income is interest income included in gross tested income.
- There are special rules in the definition of specified interest expense that take into account interest income and associated assets that meet the active financing or insurance exceptions under IRC §954(h) and (i)).

Specified Interest Expense Example

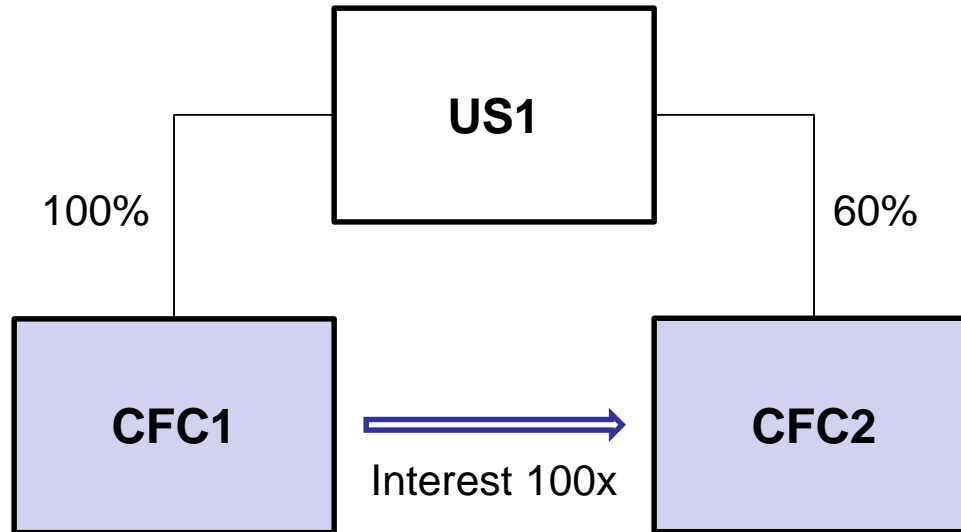

US1's pro rata share of tested income* from...	...includes interest expense (income) of...
CFC1	100x
CFC2	(60x)

US1 has specified interest expense of 40x.

Specified Interest Expense Example

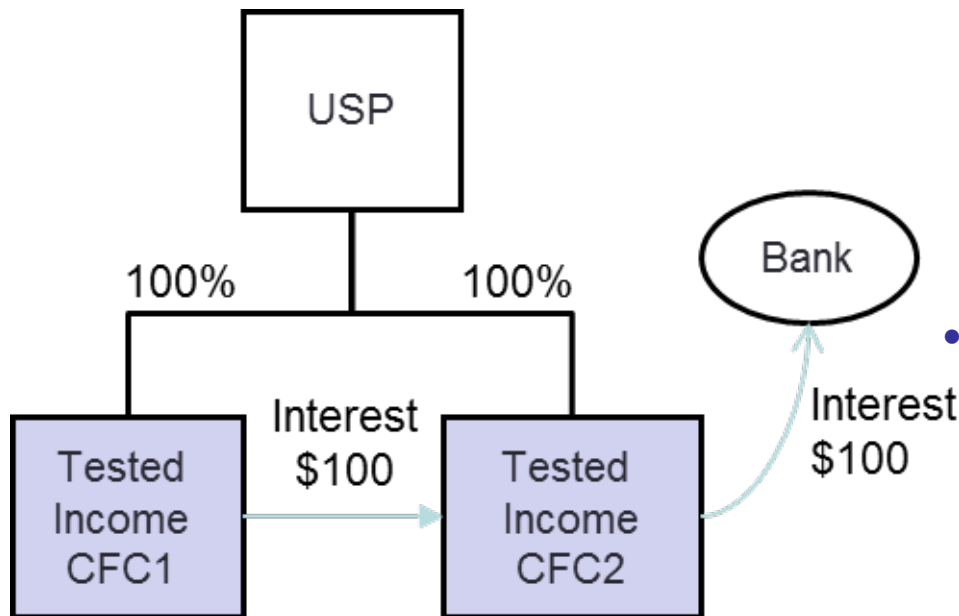

- CFC1's interest payment of \$100 to CFC2 does not reduce net DTIR because the \$100 of interest income is included in CFC2's tested income (and the \$100 is taken into account to determine USP's net CFC tested income).
- CFC2's interest payment of \$100 to Bank, however, does reduce net DTIR because the interest income attributable to CFC2's interest expense is not taken into account in determining USP's net CFC tested income (the interest income is received by a unrelated third party).
- The regulations adopt a netting approach that allows taxpayers to incorporate this rule in a practical way.

Specified Interest Expense

- Specified interest expense includes the interest expense of a CFC with a tested loss.
- However, the final regulations reduce the tested interest expense of a tested loss CFC (and ultimately, the specified interest expense of a US shareholder) by an amount equal to the notional return on the QBAI that the tested loss CFC would have had if the CFC were instead a tested income CFC. Treas. Reg. §1.951A-4(b)(1)(i) and (iv) and (c) Example 5.

Tested Loss CFC Notional QBAI Example

- CFC-level determination; tested interest expense and tested interest income
 - CFC1 has \$200 of tested interest expense and no tested interest income.
 - CFC2 has \$200 of tested interest income and basis of \$1,500 in tangible property that would be QBAI if CFC2 were instead a tested income CFC (“notional QBAI”).
 - CFC2’s tested interest expense is \$350 (\$500 interest expense – [10% of \$1,500 notional QBAI]).

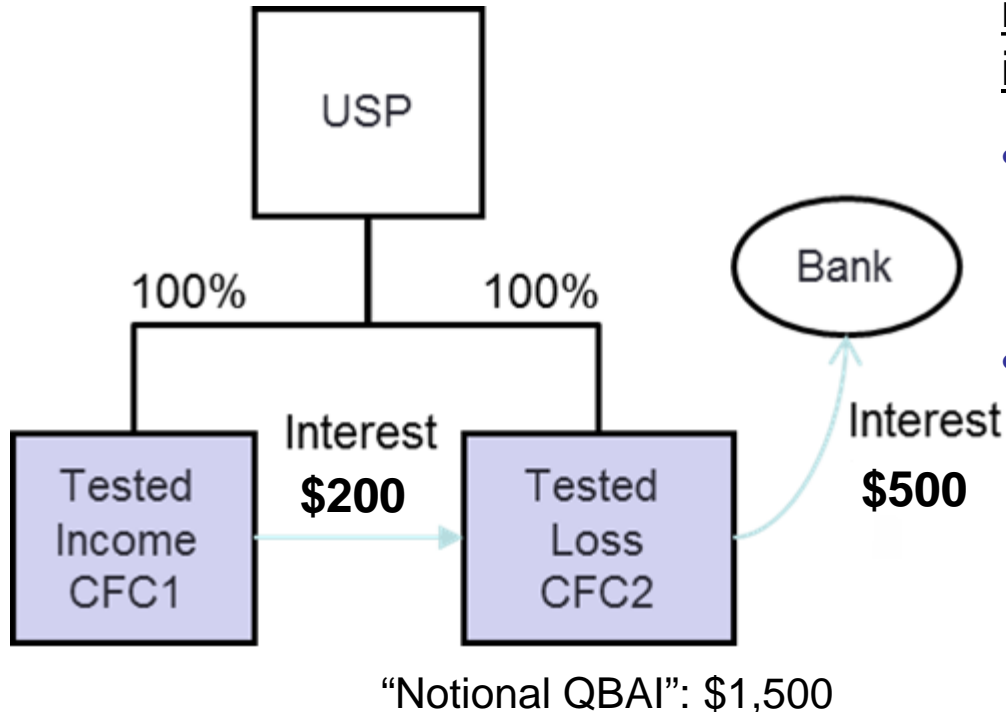

Tested Loss CFC Notional QBAI Example

- US shareholder-level determination; pro rata share and specified interest expense.
- USP's pro rata share of CFC1's tested interest expense is \$200, its pro rata share of CFC2's tested interest expense is \$350, and its pro rata share of CFC2's tested interest income is \$200.
- USP's aggregate pro rata share of tested interest expense is \$550, and its aggregate pro rata share of tested interest income is \$200.
- Accordingly, USP's specified interest expense is \$350 (\$550 - \$200).

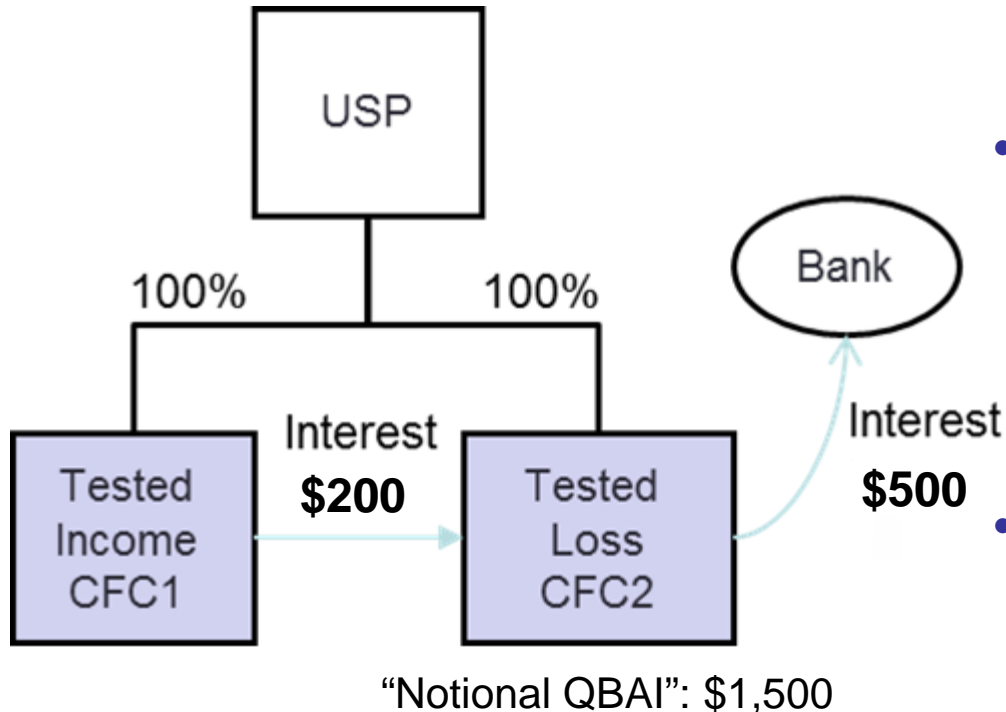

Tested Loss CFC Notional QBAI Example

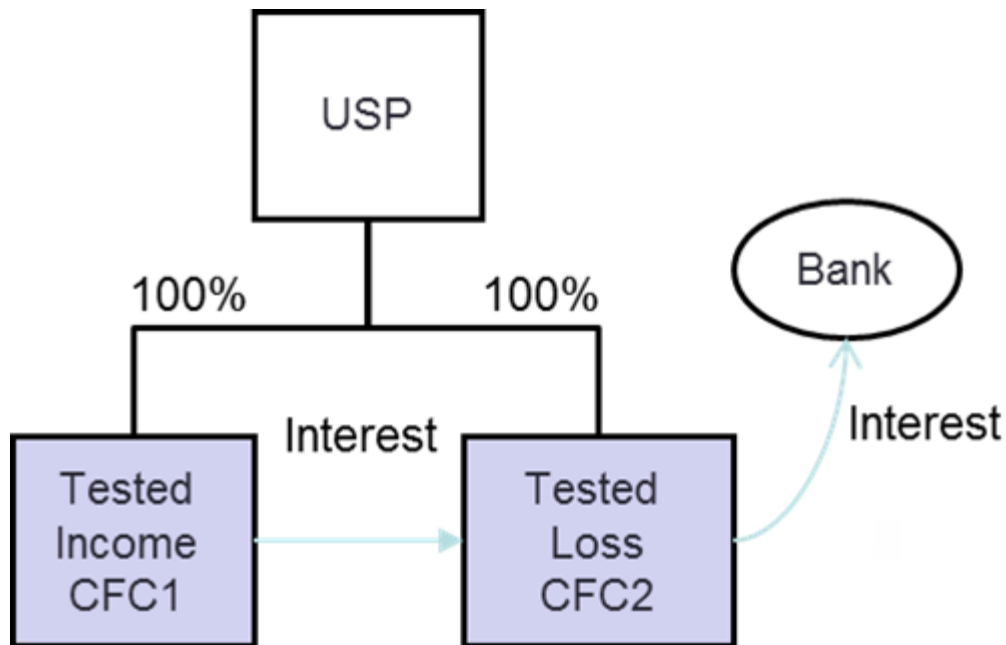

- If the tested loss CFC notional QBAI rule did not exist...
- CFC1 would have tested interest expense of \$200; CFC2 would have tested interest expense of \$500 and tested interest income of \$200.
- USP's aggregate pro rata share of its CFC's tested interest expense would be \$700 and the aggregate pro rata share of tested interest income would be \$200, resulting in specified interest expense of \$500.
- This would reduce USP's DTIR, which would effectively increase the GILTI inclusion.

GILTI Inclusion

- A US shareholder of a CFC that owns stock of the CFC within the meaning of §958(a) must include in gross income its GILTI for the taxable year. §951A(a).
- A US shareholder's GILTI inclusion under §951A is treated as an amount included under §951(a)(1)(A) for certain provisions of the Code, including:
 - Previously-taxed earnings and profits (PTEP) (sometimes called PTI) (§959),
 - Basis adjustments (§961),
 - §962 elections,
 - §1248(b)(1) & (d)(1), and
 - Six-year statute of limitations §6501(e)(1)(C).
- There is authority to extend treatment to other Code sections by regulation under §951A(f)(1)(B).



Allocation of GILTI among CFCs

- US shareholder's GILTI is allocated among CFCs with respect to which the shareholder is a US shareholder. §951A(f)(2) and Treas. Reg. §1.951A-5(b)(2).
- Amount of GILTI allocated to a CFC is:
 - If CFC has no tested income, zero, and
 - If CFC has tested income, proportionate amount based on relative tested income of each such CFC. §951A(f)(2).
- Amount of GILTI with regards to a particular CFC is relevant, for example, in determining deemed paid taxes, PTEP, and basis adjustments with respect to the CFC.

Consolidated Groups

- Final regulations generally adopt a “single US entity” approach for consolidated groups, with important nuances:
 - The consolidated group aggregates the pro rata shares of QBAI, tested loss, and specified interest expense of each consolidated group member.
 - A portion of each consolidated CFC tested item is allocated back to each member based on the member’s GILTI allocation ratio, which equals the ratio of the member’s aggregate pro rata share of tested income to consolidated tested income.

Treas. Reg. §1.1502-51(b).

Anti-Abuse Rules 1

- Adjusted basis in temporarily-held specified tangible property is disregarded (and therefore not included in QBAI)
- For certain asset transfers by FYE CFCs during the disqualified period*:
 - Deductions/losses related to disqualified basis do not reduce gross tested income, subpart F income, or ECI.
 - Disqualified basis is disregarded for purposes of determining QBAI.

* “GILTI holiday”, “gap-year”, and “donut hole” transactions are some of the names taxpayers and tax professionals have used to refer to these transactions.

Anti-Abuse Rules 2

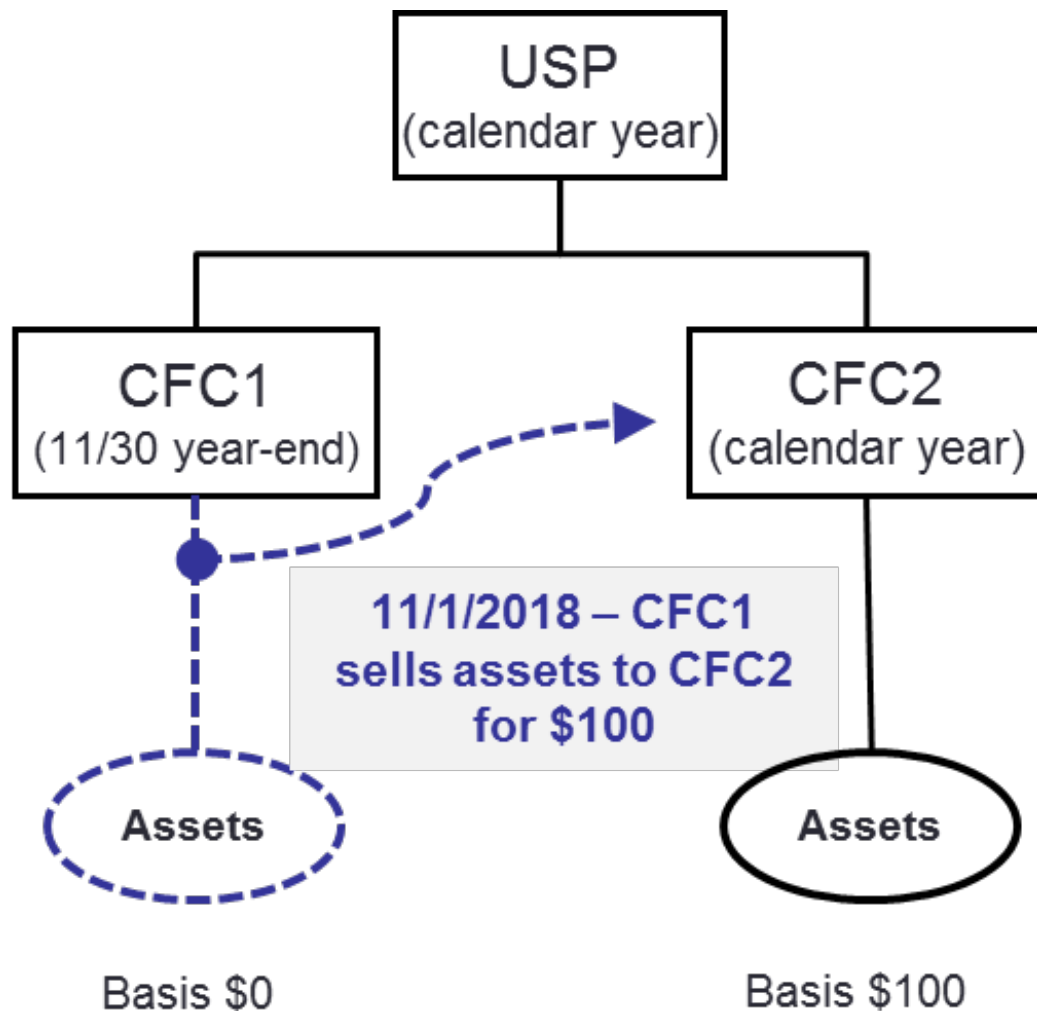

Anti-Abuse Rules 3

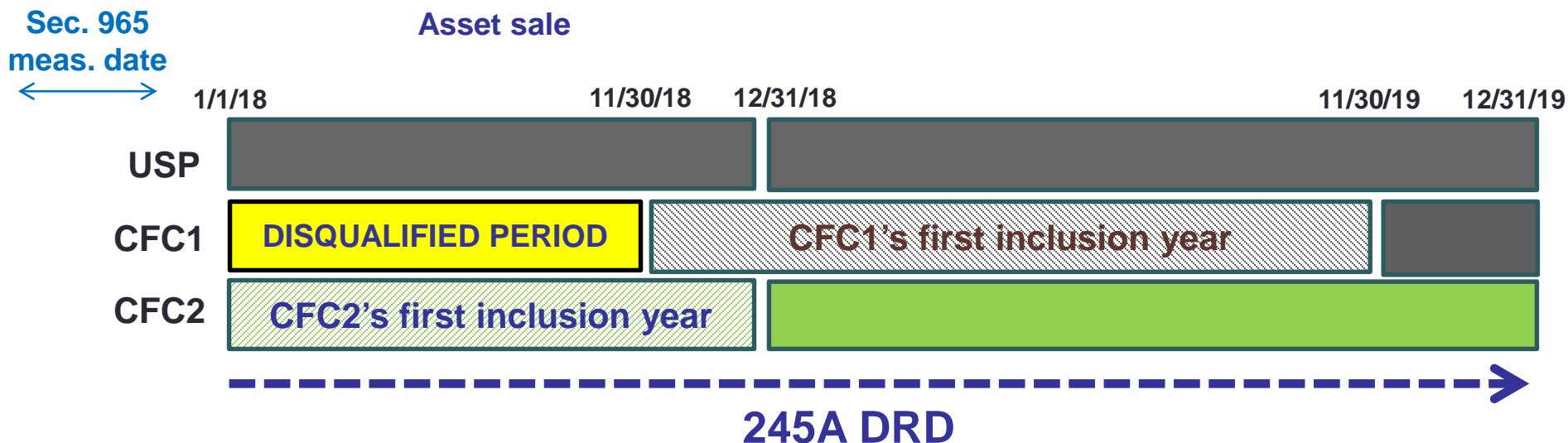

- Not subject to GILTI under §951A: Gain realized by CFC1 is not tested income because CFC1 realizes the gain during the taxable year prior to the first taxable year that GILTI applies to CFC1.

Anti-Abuse Rules 4

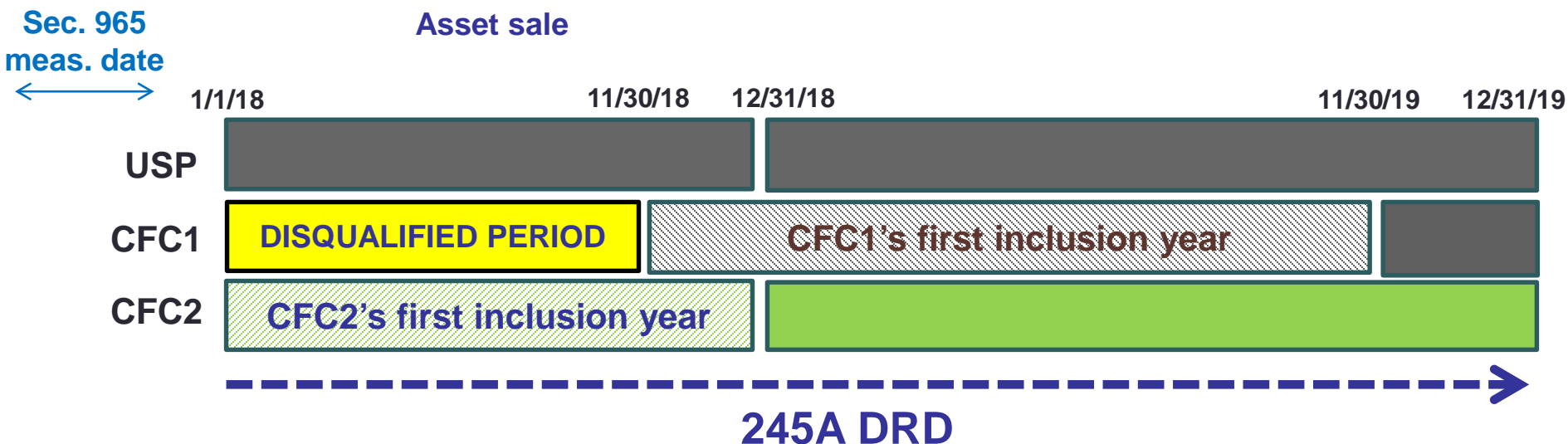

- Not subject to transition tax under §965: Gain realized by CFC1 is excluded from earnings subject to §965 transition tax because gain arises after the §965 E&P measurement dates (November 2nd and December 31st, as applicable).

Anti-Abuse Rules 5

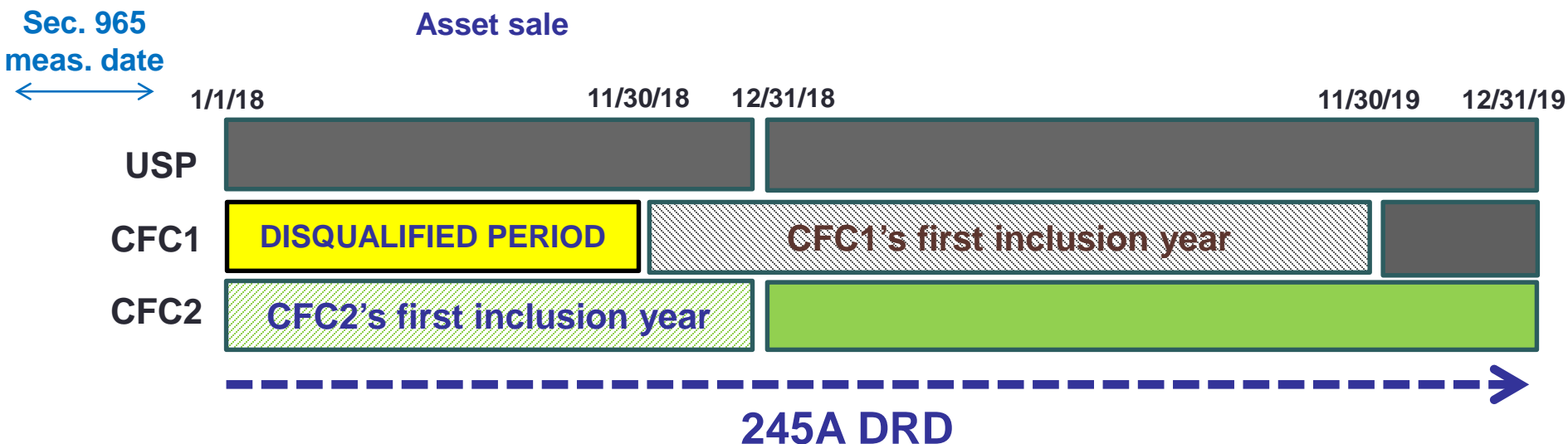

- Dividends-received-deduction under §245A: A dividend from CFC1 to USP may qualify for §245A dividends-received-deduction (assuming certain requirements are met).

Applying the GILTI Rules



Example

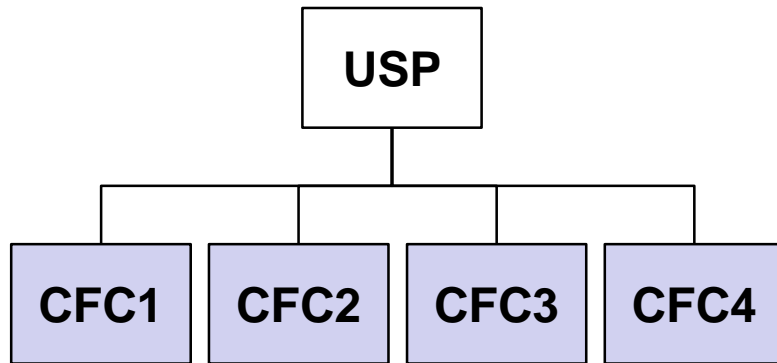

	CFC1	CFC2	CFC3	CFC4
Gross TI / (TL)	700x	150x	400x	0
Tangible property	100x	600x	0	800x

FACTS:

- USP owns 100% of CFC1, CFC2, CFC3, and CFC4, none of which have any FBCI or ECI.
- CFC1 makes a substantial contribution to the manufacture of product X, which CFC1 sells to customers. CFC1 has 700x tested income and specified tangible property with an average basis of 100x.
- CFC2 physically manufactures product X and has 150x tested income and tangible property with a basis of 600x.
- CFC3 develops & licenses IP to CFC2 for use in manufacturing product X. CFC3 has 400x tested income and no tangible property.
- CFC4 provides services to unrelated parties and has no tested income and tangible property with a basis of 800x.

Example

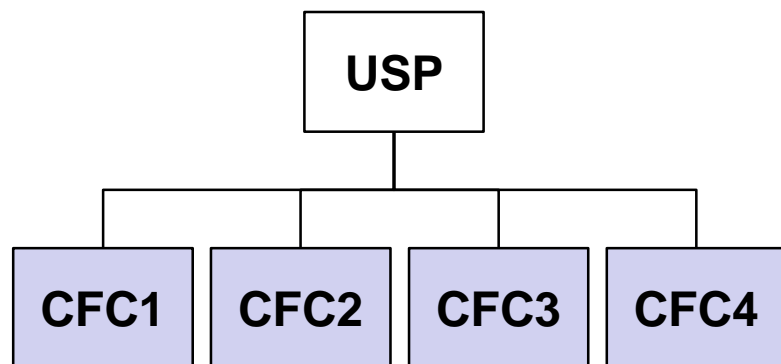

	CFC1	CFC2	CFC3	CFC4
Gross TI / (TL)	700x	150x	400x	0
Tangible property	100x	600x	0	800x
Deductions properly allocable	200x	50x	100x	300x
Tested interest expense	0x	30x	10x	100x

FACTS (Cont'd):

- The deductions properly allocable to the gross tested income of CFC1, CFC2, CFC3 and CFC4 are 200x, 50x, 100x, and 300x, respectively.
- The tested interest expense of CFC1, CFC2, CFC3 and CFC4 is 0x, 30x, 10x, and 100x, respectively.
- None of the CFCs have tested interest income.

Step 1

Step 1: Calculate Net CFC Tested Income

	CFC 1	CFC 2	CFC 3	CFC 4
Gross Income	700x	150x	400x	-0-
Less: exclusions				
ECI (Loss)	-0-	-0-	-0-	-0-
Subpart F Inclusions	-0-	-0-	-0-	-0-
High Tax Exception	-0-	-0-	-0-	-0-
R/P Dividends	-0-	-0-	-0-	-0-
FOGEI	<u>-0-</u>	<u>-0-</u>	<u>-0-</u>	<u>-0-</u>
Gross tested income	700x	150x	400x	-0-
Less: properly allocable deductions	<u>200x</u>	<u>50x</u>	<u>100x</u>	<u>300x</u>
CFC Tested Income (Loss)	<u>500x</u>	<u>100x</u>	<u>300x</u>	<u>(300x)</u>

$$\begin{aligned} \text{Net CFC Tested Income} &= \sum \text{CFC Tested Income} - \sum \text{CFC Tested Loss} \\ &= (500x + 100x + 300x) - 300x \\ &= \underline{\underline{\$600x}} \end{aligned}$$

Step 2

Step 2: Calculate the US shareholder's net deemed tangible income return

	<u>CFC1</u>	<u>CFC2</u>	<u>CFC3</u>	<u>CFC4</u>	
US shareholder's aggregate pro rata share of QBAI	= 100x	+ 600x	+ 0	+ 0*	= 700x

US shareholder's specified interest expense	= 0	+ 30x	+ 10x	+ 20x**	= 60x
--	-----	-------	-------	---------	--------------

$$\begin{aligned} \text{Net DTIR} &= [(10\% \times \text{Aggregate QBAI}) - \text{Specified Interest Expense}] \\ &= (10\% \times 700x) - 60x \\ &= \underline{10x} \end{aligned}$$

* CFC4 is a tested loss CFC, so its QBAI is zero.

**If CFC4 were not a tested loss CFC, its QBAI would be 800x, so its tested interest expense of 100x is reduced by 80x (i.e. 10% of 800x).

Step 3

Step 3: Calculate the US shareholder's GILTI

$$\begin{aligned} \text{GILTI} &= \text{Net CFC Tested Income} - \text{Net DTIR} \\ &= 600x - 10x \\ &= \underline{590x} \end{aligned}$$

Step 4

Step 4: Allocate the US shareholder's GILTI among CFCs

CFC's Allocated GILTI = GILTI x (CFC's Tested Income ÷ Aggregate CFC Tested Income)

CFC1	=	590	x	500x	÷	900x	=	<u>328x</u>
CFC2	=	590	x	100x	÷	900x	=	<u>65x</u>
CFC3	=	590	x	300x	÷	900x	=	<u>197x</u>
CFC4	=	590	x	0x	÷	900x	=	<u>0</u>

Question: Why do we allocate GILTI among the CFCs?

Answer: PTEP, basis adjustments, FTCs, and future §986(c) FX gain/loss.

GILTI Inclusion and FTC Implications

GILTI Inclusions for Corporate US Shareholders

- The GILTI inclusion is generally taxed at an effective tax rate (before FTCs) of at most 10.5% (13.125% beginning in 2026) because corporate US shareholders are generally entitled to a deduction equal to 50% of the GILTI inclusion (37.5% beginning in 2026) under § 250.
- They are deemed to have paid 80% of the foreign income taxes paid/accrued by the CFC with respect to the CFC's tested income that results in the US shareholder's GILTI.
- GILTI of the US shareholder is generally in the GILTI category for FTC purposes (with no FTC carryover or carryback).
- The GILTI inclusion is “grossed up” under § 78 to include 100% of the taxes deemed paid with respect to GILTI.

GILTI Inclusions for Individual US Shareholders

- Individual US shareholders are generally not eligible for the deduction under § 250 or FTCs with respect to GILTI.
- However, individual US shareholders that elect under §962 to be taxed at corporation rates may reduce their taxable income by the portion of the § 250 deduction that would be allowed and claim FTCs under § 960 with respect to GILTI. Proposed §1.962-1(b)(1)(i)(B)(3).
- But § 962 does not put individual US shareholders on equal footing with corporate US shareholders, because individuals with a § 962 election in place are taxed a second time when the CFC distributes its earnings.

Comparing and Contrasting GILTI and Subpart F

GILTI and Subpart F

- A GILTI inclusion is similar, but not identical, to a subpart F inclusion.
 - GILTI is computed at the US shareholder level; subpart F income items (e.g. FBCI) are determined at the CFC level.
 - GILTI generally allows a loss from one CFC to offset income from another CFC (*i.e.*, net CFC tested income); subpart F income from one CFC generally may not be offset by subpart F loss of another CFC.
 - GILTI is a taxable income concept (not limited to E&P); subpart F income is based on, and limited to, current E&P (§952(c)(1)) increased by tested loss.

Key Differences

GILTI	Subpart F Income
<ul style="list-style-type: none">• US shareholder level concept	<ul style="list-style-type: none">• CFC level concept
<ul style="list-style-type: none">• Inclusion is a formula-driven computation not dependent on the type of income	<ul style="list-style-type: none">• Inclusion is based on specifically defined types of income
<ul style="list-style-type: none">• Losses from one CFC may offset income from another CFC	<ul style="list-style-type: none">• Subpart F income of one CFC is not offset by losses of another CFC
<ul style="list-style-type: none">• Taxable income concept; not limited to E&P	<ul style="list-style-type: none">• E&P concept; limited to CFC's current E&P (increased by tested loss)

Forms

Forms

- 2018 Forms are here:

<https://www.irs.gov/forms-instructions>

- You can view the 2019 draft forms on the Early Release website...

<https://www.irs.gov/draftforms>

Form 5471, Schedule I-1

**SCHEDULE I-1
(Form 5471)**

(December 2018)

Department of the Treasury
Internal Revenue Service

Information for Global Intangible Low-Taxed Income

OMB No. 1545-0123

▶ Attach to Form 5471.

▶ Go to www.irs.gov/Form5471 for instructions and the latest information.

Name of person filing Form 5471		Identifying number
Name of foreign corporation		EIN (if any)
		Reference ID number (see instructions)

Separate Category (enter code—see instructions) ▶		Functional Currency	Conversion Rate	U.S. Dollars
1	Gross income	1		
2	Exclusions			
a	Effectively connected income	2a		
b	Subpart F income	2b		
c	High-tax exception income per section 954(b)(4)	2c		
d	Related party dividends	2d		
e	Foreign oil and gas extraction income	2e		
3	Total exclusions (total of lines 2a–2e)	3		
4	Gross income less total exclusions (line 1 minus line 3)	4		
5	Deductions properly allocable to amount on line 4	5		
6	Tested income (loss) (line 4 minus line 5) (see instructions for line 6)	6		
	Other Amounts (see instructions)			
7	Tested foreign income taxes	7		
8	Qualified business asset investment (QBAI)	8		
9	Interest expense	9		

Form 8992

Form **8992**

(December 2018)

Department of the Treasury
Internal Revenue Service

U.S. Shareholder Calculation of Global Intangible Low-Taxed Income (GILTI)

► Go to www.irs.gov/Form8992 for instructions and the latest information.

OMB No. 1545-0123

Attachment
Sequence No. **992**

Name of person filing this return	A Identifying number
Name of U.S. shareholder	B Identifying number

Part I Net Controlled Foreign Corporation (CFC) Tested Income (see instructions)		
1	Sum of Pro Rata Share of Net Tested Income (total from Form 8992–Schedule A, line 1, column (e))	1
2	Sum of Pro Rata Share of Net Tested Loss (total from Form 8992–Schedule A, line 1, column (f))	2 ()
3	Net CFC Tested Income (combine line 1 and line 2) (if zero or negative, stop here)	3

Part II Calculation of Global Intangible Low-Taxed Income (GILTI)		
1	Net CFC Tested Income (from Part I, line 3)	1
2a	Pro Rata Share of QBAI multiplied by 10% (total from Form 8992–Schedule A, line 1, column (g))	2a
b	Specified Interest Expense (total from Form 8992–Schedule A, line 1, column (i))	2b
c	Net Deemed Tangible Income Return (DTIR) (subtract line 2b from line 2a) (if zero or less, enter -0- here)	2c
3	GILTI (subtract line 2c from line 1) (see instructions)	3

For Paperwork Reduction Act Notice, see separate instructions.

Cat. No. 37816Y

Form **8992** (12-2018)

Planning and Takeaways



Taxpayer Planning

Taxpayers may try to reduce GILTI and the resulting tax by...

- Making a 962 election for an individual to be taxed at corporate rates.
- Checking the box to treat CFCs as DEs of a Super Holdco CFC
- Allocating expenses to non-GILTI FTC baskets and/or broadly construing taxes attributable to GILTI
- Selling specified tangible property to related CFC to increase tax basis
- Planning into subpart F income
- Adjusting transfer pricing to avoid tested loss CFC
- Other

Key Takeaways

- Should we stop auditing subpart F & other issues that involve the E&P of a CFC in open years prior to the new law's effective date?
- No! Why? To protect the government's interest because of the decline in tax rates (pre-repatriation year tax rates are higher) & to make sure that the beginning E&P for the repatriation year is correct.
- §951 subpart F income is picked up before the §965 repatriation amount and taxed at a higher rate.
- Old law taxation of CFC income: now or deferral
- New law taxation of CFC income: now or never (if domestic corporate shareholder)

Lesson Summary

Now you are able to:

- Identify US shareholders and controlled foreign corporations
- Describe the new GILTI regime;
- Apply the new GILTI rules;
- Describe the FTC implications for GILTI; and
- Compare and contrast the GILTI and subpart F regimes.
- Identify relevant forms.
- Identify taxpayer planning strategies and key takeaways.

Questions



Contacts & Resources

If you need additional assistance or information:

- Visit the CFC Income (fka Deferral Planning) PN SharePoint site and refer to our units in the practice library
- <https://portal.ds.irsnet.gov/sites/vl008/lists/deferralplanning/landingview.aspx>
- Contact the CFC Income (fka Deferral Planning) PN

Glossary

Acronym	Definition
ADS	Alternative depreciation system
CFC	Controlled foreign corporation
DE	Disregarded entity
DRD	Dividends received deduction
DTIR	Deemed tangible income return
E&P	Earnings and profits
ECI	Effectively connected income



Glossary

Acronym	Definition
FBCI	Foreign base company income
FBCSI	Foreign base company sales income
FBCSvcl	Foreign base company services income
FC	Foreign corporation
FPHCI	Foreign personal holding company income
FOGEI	Foreign oil and gas extraction income
GILTI	Global intangible low-taxed income

Glossary

Acronym	Definition
NPRM	Notice of proposed rulemaking
PS	Partnership
PTEP	Previously taxed earnings and profits
PTI	Previously taxed income
QBAI	Qualified business asset investment
TCJA	Tax Cuts & Jobs Act
USP	United States parent

Thank You

Thank you for your participation!